

KONAMI

ubeat

COPIOUS APPEND

Ubeat Copios Append



Installation, operation, maintenance, parts diagrams, wiring diagrams

operating instructions

GQK44-JD



⚠ Mishandling the product may result in breakdowns or accidents, so be sure to read this manual carefully before use, fully understand it before use, and follow the instructions in this manual. ⚠ Keep this manual in a safe place so that you can refer to it immediately when necessary.

Regarding use of this product

Thank you very much for purchasing this product. This manual provides instructions for operating the product safely and correctly.

• This product is the "Ubeat Copios Append (GQK44-JD)".

• Please be sure to read.

• This product is e-AMUSEMENT compatible game software. "e-AMUSEMENT" is an online service for amusement machines that connects our company with amusement facilities nationwide via a network. To use this online service, you must sign a contract with our company.

• Even if the equipment is normal, online services may not be available due to line failures. If you are unable to connect or the line is cut off when using the e-AMUSEMENT service, this may be due to problems or maintenance on the part of your contracted line operator or provider. In this case, please contact your line operator or provider, or check the status on the website of each provider.

• If online services are unavailable due to line problems, etc., you will not be able to play online. In that case, you will also not be able to use the "e-AMUSEMENT PASS." (Page 30)

- The e-AMUSEMENT function of this product is for broadband use only and cannot be used with ISDN lines.

• This product is a game software compatible with "PASELI".

"PASELI" is an electronic money operated by our company.

"PASELI" can be used with "PASELI" compatible products at e-AMUSEMENT compatible stores. To use the "PASELI" service, you must enter into a contract with us. (Page 32)

ÿ  This product is equipped with RSA BSAFE® software from EMC Corporation of the United States.

ÿ RSA and BSAFE are trademarks or registered trademarks of EMC Corporation in the United States and other countries.

ÿ If you have any questions about the contents of this manual, please contact the after-sales service desk.

Please contact us.

ÿ This product and software may be considered strategic materials regulated by the Foreign Exchange and Foreign Trade Control Law.

ÿ This product is for use in Japan only. Do not take it outside of Japan.

We shall not be liable for any trouble, malfunction, or damage that may occur due to taking the product outside of Japan.

ÿ The game content, main mechanism, and design of this product are protected by patent law, copyright law, and other laws. Protected by other intellectual property laws.

ÿ Unauthorized reproduction of all or part of the contents of this manual is strictly prohibited. ÿ Copying all or part of the software of this product is prohibited. ÿ Analyzing or using the internal programs by reverse engineering or other methods is prohibited. In addition, you should not instruct, force, or request a third party to perform reverse engineering.

Reverse engineering includes disassembly, decompilation, and other extraction of source code.

Includes outgoing.

4. Table of Contents

Before using this product.....	2
For your safety.....	7
Please read this.....	8
Location of Warning Labels.....	19
1 Specifications	21
2 Product composition.....	twenty five
3 e-AMUSEMENT Service	29
e-AMUSEMENT PASS.....	30
PASELI.....	32
4 Names of parts	35
About the power supply	39
Opening and closing the service door	40
Service panel	41
Opening and closing the coin door	42
5 How to play	45
6 Game Settings	49
Checking the game startup.....	50
Setting and adjusting the game contents.....	51
Explanation of each menu item.....	53
Adjusting the LCD display.....	104
7 Management	109
Start-up Inspection.....	110
Periodic Inspection.....	112
8 Daily Maintenance	113
Cleaning the Main Unit.....	114
Cleaning the Ventilation Holes.....	116
Cleaning the Backside of the Panel Unit.....	123
Cleaning the Inside of the Display Cover.....	129

9 Installation and Assembly	133
Installation and Assembly.....	134
Installation 1 Fixing the Adjuster.....	135
Installation 2 Setting the Account Key and License Key	137
Installation 3 Setting the Security Plug (Black)	139
Installation 4 Network Connection	142
Installation 5 Confirming e-AMUSEMENT Service Use	145
Installation 6 Initial Startup Settings	150
Installation 7 Attaching the Pop	152
10 Maintenance	155
When relocating the coin counter	156
Replacing the coin selector	159
Replacing the rubber switch	162
Replacing the hard disk unit	175
Resetting the circuit protector	182
11 Troubleshooting	183
When the device does not operate normally	184
Error Code and Message List	195
12 Appendix	199
Decorative parts	200
Parts diagram	202
Wiring diagram	257
After-sales service	262



Safety Instructions

8 Safety Instructions



This manual describes the precautions that must be observed to prevent injury to those installing, using or maintaining this product, as well as to other people, and damage to property, as follows:

Please read

ÿ The degree of danger or damage that may occur when the instructions are ignored and the product is used incorrectly is classified using the following symbols.

 caveat	This symbol indicates that "there is a possibility of death or serious injury."
 Note	This symbol indicates that "there is a possibility of injury or property damage."

ÿ The following symbols are used to explain the types of precautions you must take.

	This pictogram indicates a warning that you should be careful of.
	This pictogram indicates something that is "prohibited" and must not be done.
	This pictogram indicates something that is "mandatory" and must be done.

ÿ Definition of store maintenance staff and technicians who handle this product

ÿ Any tasks instructed to be performed by a "store maintenance person" or "technician" in the instructions given in this manual must be performed by someone with the necessary knowledge and skills. - Failure to do so may result in electric shock, breakdown or a serious accident. - Part replacement, maintenance and inspection of this product, and dealing with abnormalities should be performed by a "store maintenance person" or "technician". This manual instructs that particularly dangerous tasks should be performed by a "technician". The definitions of "store maintenance person" and "technician" are as follows:

What is a store maintenance technician?

- A person who has experience in the maintenance of amusement machines, coin exchange machines, etc., and who, under the management of the owner or operator of the amusement machine (this product), is involved in the daily maintenance and management of the equipment through assembly, installation, maintenance and inspection, and replacement of units and consumable parts within the facility or store.

Actions of store maintenance staff - Assembly,

installation, maintenance and inspection of amusement machines and coin exchange machines, and replacement of units and consumable

parts. What is a

technician? - A person who works at an amusement machine manufacturer and is involved in the design, manufacture, inspection and maintenance services of equipment, as well as a person who has specialized technical knowledge in electrical, electronic and mechanical engineering equivalent to or higher than a technical high school graduate and is involved in the daily maintenance and

repair of amusement

machines. Actions of a technician - Assembly, installation, repair and adjustment of electrical, electronic and mechanical parts of amusement machines and coin exchange machines.

When installing



caveat

ÿ When installing, moving or transporting this product, be sure to consult with our after-sales service department.

- If

anyone other than a professional installs, moves or transports the product, it may result in injury or damage to the product.

ÿ When installing this product, be sure to ground all four adjusters to the floor and check that it is level and not wobbly. If the product is fixed in an unstable position, it may shake and cause injury or accidents.

ÿ When installing this product, do not apply excessive force to the opening and closing parts. This may cause injury, accidents, or damage.



禁止

ÿ Never install outdoors. - This product is an indoor game console. Installing it outdoors may cause accidents or malfunctions.



禁止

ÿ Do not install this product near emergency exits of buildings.

- In the event of a disaster, people may not be able to evacuate and may be killed or injured.



禁止

ÿ Do not install this product in the following locations: - This may cause an accident or malfunction.



禁止

- Places where condensation occurs due to rain leaks or humidity - Places exposed to direct sunlight - Places directly exposed to heat from air conditioning or heating appliances - Near flammable materials such as kerosene or paint thinner - On slopes or unstable floors with little strength - Near firefighting equipment - Places with strong vibrations - Dusty places - Near devices that generate strong magnetic or radio waves - Places where a high-pressure washer is used

ÿ Do not place containers containing water or chemicals or objects on or near this product. If moisture or foreign objects get inside the product, it may cause electric shock or malfunction.



禁止

ÿ Do not place objects near the ventilation holes.

If ventilation is blocked, the internal temperature may rise abnormally, resulting in a fire or malfunction.



禁止

ÿ Do not forcibly bend the AC power cord or LAN cable, or place objects on the cords.

Failure to

do so may result in an electric shock, fire, or other malfunction, preventing normal play.



禁止

When installing

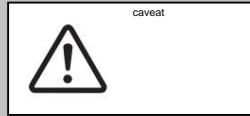

⚠ When unplugging the power plug, do not hold the AC power cord.
- The AC power cord may be damaged, resulting in a power leak or fire.



⚠ Before opening the rear door, always turn off the main power switch and unplug the power cord from the outlet.
Unplug the power cord - There is a risk of accident or electric shock.



⚠ This product is for use in Japan.

*This product is designed for use only in Japan. Using it overseas where the power specifications are different may cause a fire, accident or breakdown.



電源プラグを抜く

When installing



Note

ÿ The power source must be single-phase AC100V (90-110V) and indoor wiring must be 20A or more.

Using the product may result in fire or breakdown.

When using an extension cord, use only indoor wiring with a rating of 15A or more.

- This may cause a fire or malfunction.

ÿ Never use multiple power strips. This may result in fire or electric shock.



禁止

ÿ Always use the included AC power cord.
- This may cause a fire or malfunction.

ÿ AC power cords and LAN cables are prone to being stepped on or tripped over.
Do not place the product in a place where it may tip over and cause injury, or damage to the AC power cord, LAN cable, etc.



禁止

ÿ If you cannot make an earth connection using the 3P power plug, use the supplied 3P-2P conversion plug and be sure to connect the earth (ÿpage 39). Also, never connect the earth wire to a gas pipe or water pipe or a telephone earth terminal. Failure to connect the earth may result in electric shock or malfunction.



アースを接続する

ÿ When inserting or removing a license key, account key, or security plug, wear an earthing strap to prevent accidents caused by static electricity. Also, do not perform the work on carpets or other surfaces. -Static electricity can damage the electronic components of the device.

ÿ Do not insert or remove the license key, account key, or security plug while the PCB unit is operating.
This will prevent you from playing the game and may cause a malfunction.



禁止

ÿ Never connect any game consoles, AV equipment, communication devices, etc. to the LAN port that are not instructed in this manual. Doing so may result in the game not working properly or may cause malfunctions.



禁止

ÿ When installing this product, keep it at a distance greater than the specified distance from walls, other products, etc. (ÿPage 23) - Doing so may prevent the product from dissipating heat properly, resulting in breakdown.

ÿ When moving this product, do not use excessive force as this may cause an accident or damage.



禁止

ÿ Ensure that there is enough space for players to avoid hitting walls, other objects, etc.
Not only will this interfere with play, but it could also lead to accidents or injuries.



禁止

ÿ Do not change the dip switch settings of this product from the factory settings unless instructed to do so by our company. Doing so will result in the game not working properly.



禁止

When to use



caveat

ÿ If you notice any abnormalities such as smoke coming from the product, or an unusual odor or noise, immediately turn off the main power switch, unplug the power cord from the outlet, and discontinue use. Using the product in an abnormal condition may result in a fire or accident.



電源プラグを抜く

If an abnormality is detected,

1. Turn off the power switch.
2. Remove the power plug from the outlet.
3. Contact the after-sales service center.

ÿ Never plug or unplug the power plug with wet hands as this may result in electric shock.



禁止

ÿ The power plug is not properly inserted into the outlet or there is dust or other. Do not leave dust and dirt piled up. This can result in electric shock or fire, so check at least once a month.



禁止

When to use



Note

ÿ Do not use outside commercial and industrial areas

If used in a residential area or adjacent to a residential area, it may cause interference to televisions, radios, telephones, etc.



禁止

Players are encouraged to:

- It may cause accidents or illness, or make symptoms worse.

The following people should not play: - Those who have consumed alcohol. -

Those who are fatigued, sleep-deprived, sick, recovering from an illness, injured, or in poor physical condition. - Those who have experienced muscle spasms or loss of consciousness due to stimuli such as sound, light, or images.

- Your doctor has restricted you from exercising.

ÿ Do not impact the LCD display or glass surface - this may cause an accident or injury.



禁止

ÿ LCD displays should be operated with proper adjustment.

- Playing with a flickering or distorted screen may cause dizziness, headaches or other physical discomfort to the player and those around you.

ÿ When opening and closing the main unit, do not apply any weight or impact to it. This may cause deformation or damage to the opening and closing part.



禁止

ÿ When handling the AC power cord, observe the following: - Failure to do so may result in a power leak, fire, or electric shock.

•Do not scratch •Do not modify •Do not forcibly bend •Do not twist •Do not heat •Do not bundle •Do not pull •Do not step on •Do not pinch or hammer nails into

ÿ If the AC power cord or power plug is damaged, immediately stop using it.

Stop using the product and contact the after-sales service center to request a part replacement. Using the product in a damaged condition may result in fire or electric shock.

ÿ The e-AMUSEMENT PASS reader emits radio waves during use.

- There is a risk that the device may affect pacemakers, defibrillators, or electronic medical equipment. If you use such devices, please keep the reading unit at least 22 cm away from the device.

Precautions when handling hard disks -

Be sure to read this before handling the hard disk. - Be sure to observe the following to prevent breakdowns and accidents.

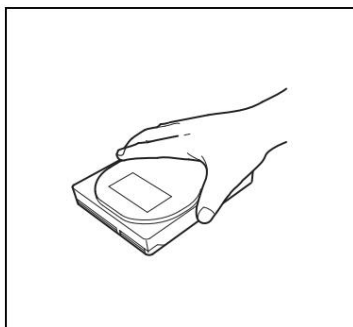

When carrying the unit, hold both sides.



Do not apply force to the main unit. This may cause a malfunction.



Do not touch the terminals. This may cause a malfunction.



Do not touch the device with hands or objects carrying static electricity. Do not bring magnetized objects near the device. This may cause a malfunction.

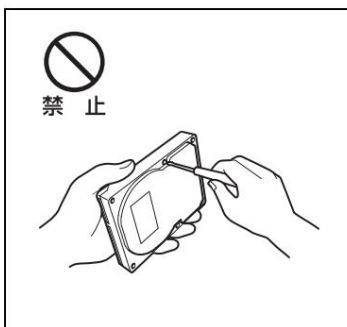

Do not disassemble or modify the product. This may cause a malfunction.



Do not remove the label

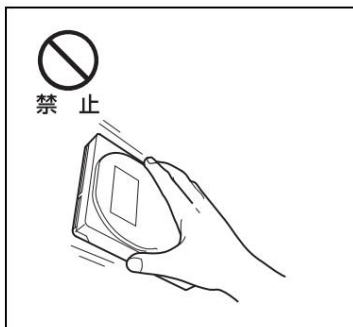

Do not subject to shock or vibration as this may cause breakdowns.



Do not drop it. This may cause a breakdown.

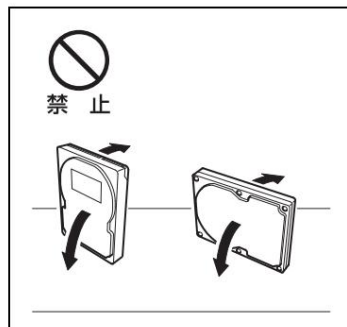

Do not place it on its side. If it falls over, it may be damaged.

•The shape of the hard disk unit in the diagram is an example.

Inspection and maintenance



caveat

ÿ When inspecting or maintaining the unit, be sure to turn off the main power switch and unplug the power cord from the outlet. Failure to do so may result in electric shock.



電源プラグを抜く

ÿ When replacing parts or consumable parts, always use parts specified by our company. Never use or mix with other parts. This can cause a fire or malfunction.



禁止

ÿ There are high voltage parts inside the unit, which is dangerous. Therefore, only a technician should remove the rear door of the unit. Also, when removing the rear door, be careful not to touch the inside of the unit carelessly, as this may result in an accident or electric shock.



禁止

ÿ When removing the rear door, be sure to turn off the main power switch of the power supply unit and unplug the power supply unit. If you turn off only the sub-power switch in the service panel without turning off the main power switch of the power supply unit, there will be parts of the unit that are still live with electricity, which may result in an accident or electric shock.



電源プラグを抜く

ÿ Never disassemble, repair, set or modify any part not specified in this manual. This may result in fire, malfunction or breakdown. For repairs, please contact the after-sales service center. We are not responsible for any damage caused by disassembly, repair, set or modify without following the instructions.



分解禁止

ÿ Never use organic solvents such as thinner, benzene, or alcohol, or detergents containing abrasives. Doing so may cause the unit to deform or become damaged. Be particularly careful not to allow any of these to come into contact with the title unit, panel, speaker, or front of the e-AMUSEMENT PASS reader. If water gets inside the unit, it may cause electric shock or malfunction.



禁止

ÿ Do not clean with a high-pressure washer, etc. If water gets inside the unit, it may cause electric shock or malfunction.



禁止



Note

ÿ The LCD display, panel and e-AMUSEMENT PASS reader are painted.
- Do not attach stickers or pop art, etc. - This may prevent normal play or cause a malfunction.



禁止

ÿ If you have used the unit for a long time, parts may become deformed or damaged due to aging, so be sure to inspect it before use. Deformed or damaged parts may cause injury to players or store maintenance staff. If you notice any deformed or damaged parts, immediately turn off the power and stop using the unit, and contact the after-sales service center.

When moving or transporting



Note

ÿ Handle with care when moving or transporting the product.

This product contains components that are sensitive to vibration and impact, such as a PCB unit, LCD display, electronic components, and precision components.

ÿ Before moving the unit, be sure to turn off the main power switch, unplug the power cord from the outlet, and remove all cables. This will prevent the unit from falling over if it is stepped on or tripped over cables.



禁止



電源プラグを抜く

ÿ Before moving the unit, be sure to disconnect all cables, raise the adjuster all the way, and use the casters to move it. Failure to do so may result in accidents, damage or malfunction.

ÿ When moving, be careful not to apply excessive force.

- This may cause accidents or damage.

ÿ When moving the product, be careful not to apply excessive force to the opening/closing parts or moving parts. This may cause injury or accidents, or damage to the product.

ÿ When moving the unit, pay attention to the direction you push it in. Depending on the direction you push it in, it may tip over. (ÿPage 24)

ÿ When moving up an incline or over a step, always have at least two people hold the handles or base. Failure to do so may cause the product to tip over, resulting in an accident or damage.

ÿ If the product is handled roughly during transportation or installation, parts may be deformed or damaged. **Be sure to inspect each part before installation to avoid injury to the player or the store maintenance staff due to deformation or damage to parts. If any parts are deformed or damaged, immediately turn off the power and discontinue use, and contact the after-sales service center.**

Disposal

ÿ When disposing of the main unit and its parts, the owner of this product must dispose of them responsibly as industrial waste.

Disposal : When

disposing of the main unit (excluding accessories), you may be able to use the Konami Recycling Service.

For details, please contact our sales representative.

ÿ Dispose of the packaging materials used at the time of shipment in accordance with local regulations.

Request

ÿ When installing, handling, inspecting, maintaining, moving or transporting the product, please follow the procedures and information in this manual safely.

ÿ Do not remove labels such as "Warning" or "Caution".

ÿ Do not install, handle, inspect, maintain, move or transport the product in any manner that corresponds to a warning or caution. please.

ÿ When the ownership of this product changes due to transfer of ownership, be sure to pass this manual on to the next owner. Sai.

ÿ If this manual is lost or damaged, please contact the after-sales service desk.

Location of warning labels

20 Location of warning labels

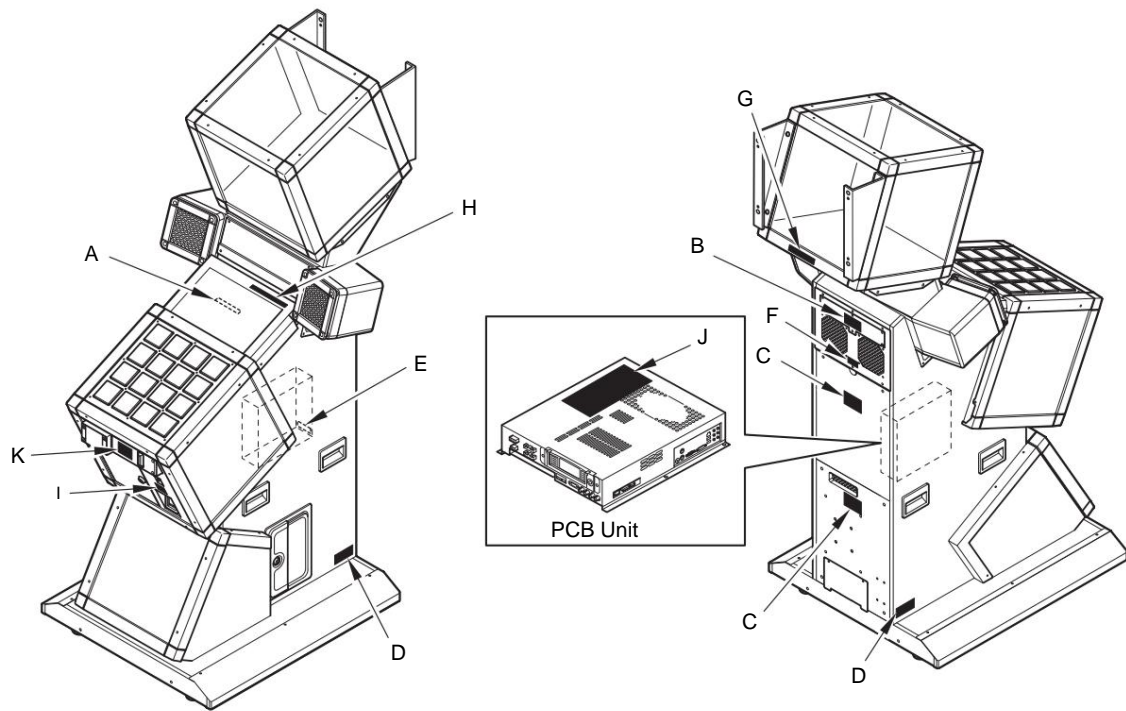

Types of warning labels

A



112376460000

B

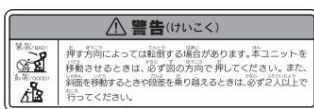

112478290000

C

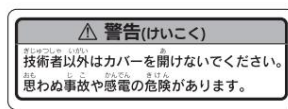

112073660000

D

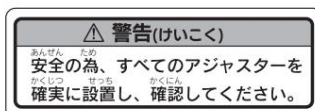

112073670000

E

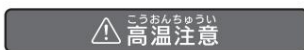

112376430000

G

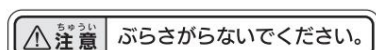

112366500000

F



112366510000

H



112366520000

I

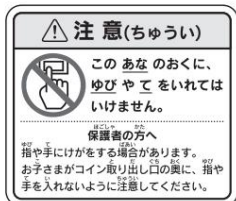

112271730000

J



112073680000

K

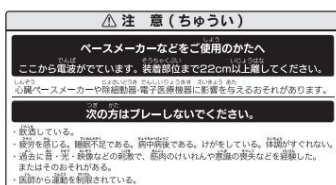

(112368430000)

• The part number in () is the part number of the material. (It is printed on the material.)
 • The label contents may differ depending on the shipping time.

1 Specifications

22 1 Specifications

u0000000000

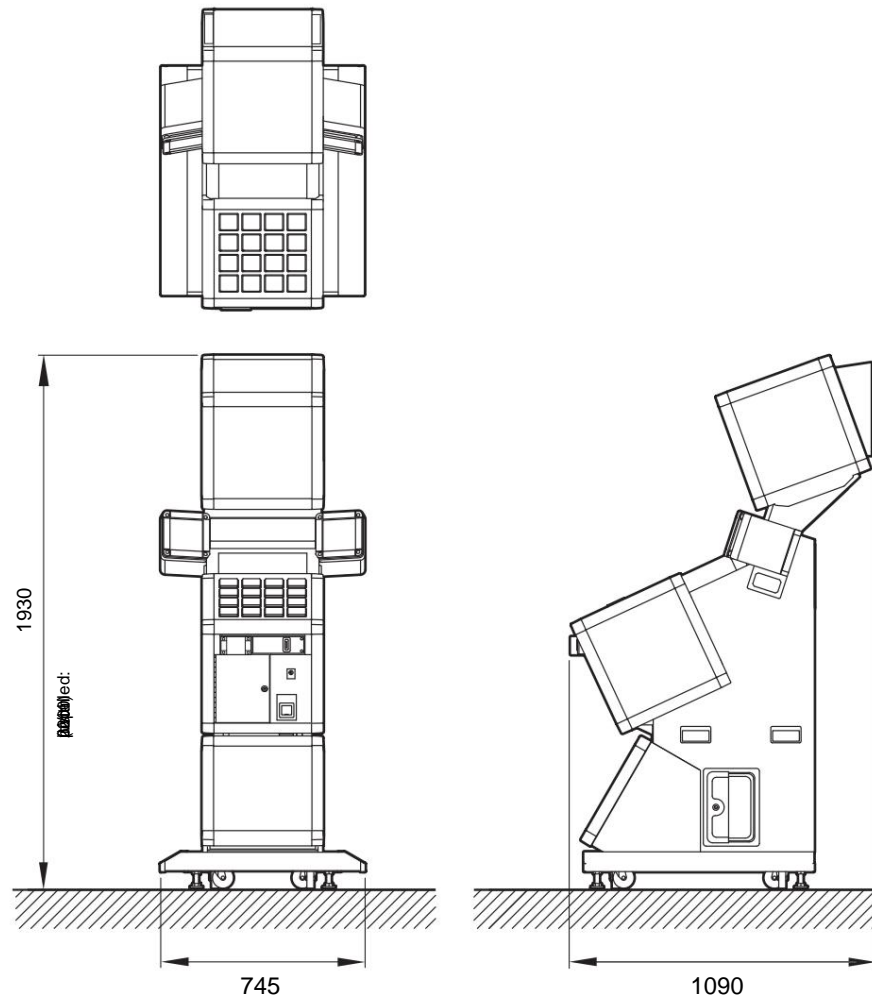

specification

External dimensions	See the diagram above (mm)
weight	Approx. 144kg
power supply	Single phase AC100V ($\pm 10\%$) 50Hz/60Hz
Rated power consumption	306W
Coin selector for 100 yen coins only	
Safe Capacity	Approximately 3000 pieces/100 yen coin
display	25.5 inch wide LCD
Terms of Use	Ambient temperature: 5 to 35°C Ambient humidity: 20 to 80% (no condensation)

- The specifications of this product may be changed without notice for performance improvement or other reasons.

• About delivery and installation dimensions

The following door dimensions are required for delivery.



• Do not carry in or move the equipment with cables still connected.

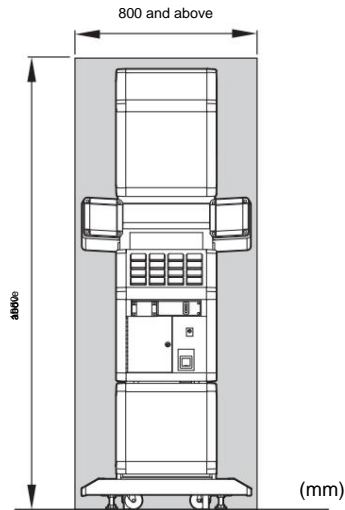

To install the unit, ensure the following space is available:



• Keep the product at a distance greater than the specified distance from walls and other products. • Do not place objects around the product.

From walls and other products

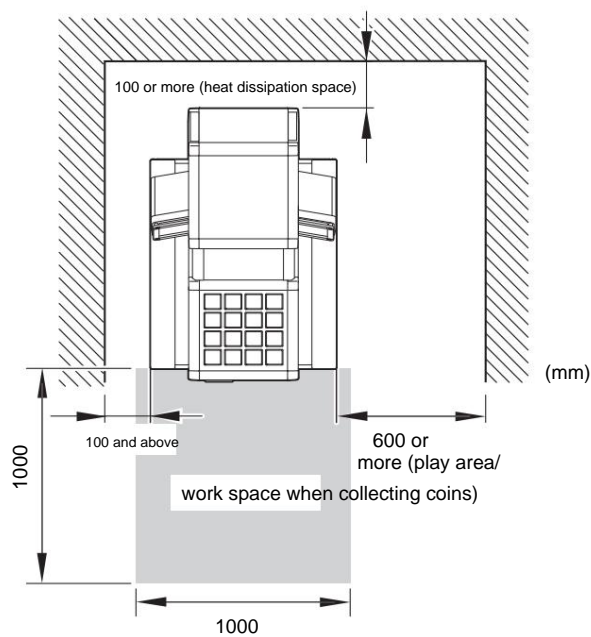

When traveling, follow these instructions:



- Before moving the unit, be sure to disconnect all cables, raise the adjuster all the way, and move the unit on the casters.
- When moving the unit, be careful not to apply excessive force to it.
- When moving the unit, be careful not to apply excessive force to opening/closing parts or moving parts.
- Use four or more people to lift the unit, and two people when moving it up a slope or over a step.
- Do the above

• When lifting the unit, always have at least four people hold the handles and the bottom of the unit. (Please be careful as the unit weighs approximately 144 kg.)

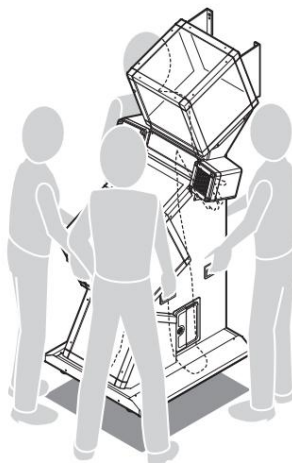

• When moving the unit using the casters, always have at least two people move it in the direction indicated by the circle in the illustration.

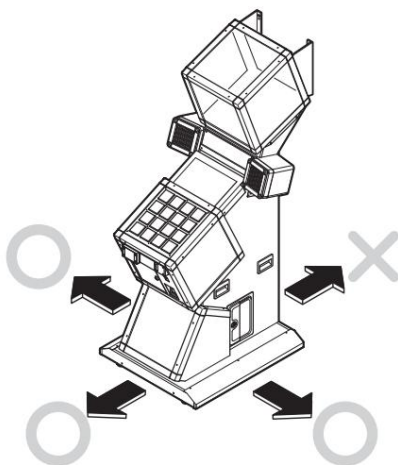

Don't do this

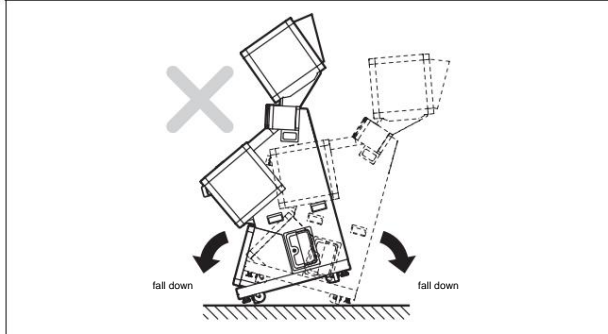

Transporting the unit at an angle is particularly dangerous, so never do so.

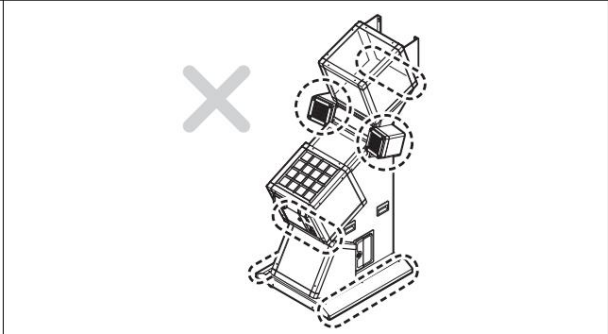

Do not lift it by holding it in the position shown in the figure.

2 product configuration

26 2 product configuration



This section describes the parts and accessories for this product. If you find any missing or defective items, please contact the after-sales service center.

Please

make sure that all the necessary parts are included. For the serial number, license number, and serial number, contact the after-sales service center.



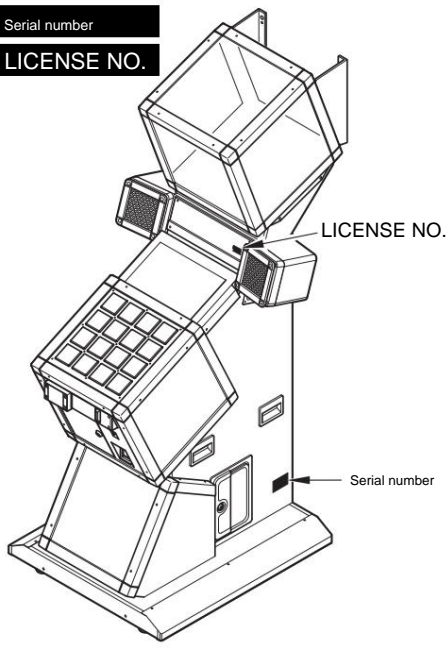
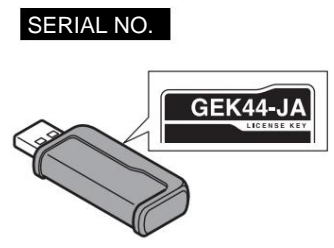
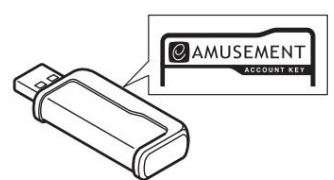
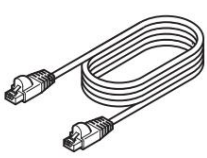
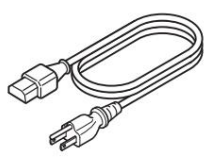
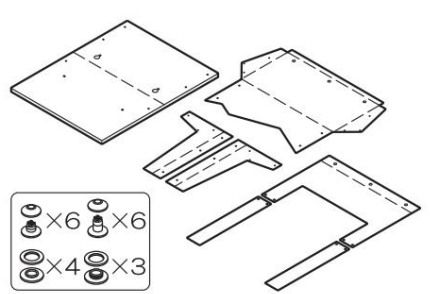

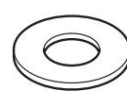
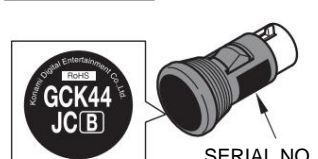

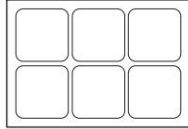

Sometimes it is necessary.

The "Serial Number", "LICENSE NO." and "SERIAL NO." are the same for each unit. If you purchase multiple units, Do not mix in this case.

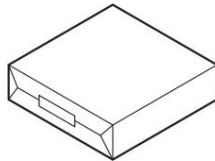
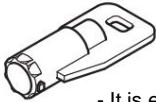
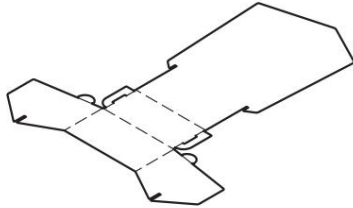
Product Name	Quantity	Product Name	Quantity
 <p>Serial number LICENSE NO.</p> <p>LICENSE NO.</p> <p>Serial number</p> <p>Main unit</p>	1	 <p>SERIAL NO.</p> <p>License key (black)</p>	1
		 <p>SERIAL NO.</p> <p>Account key (white)</p>	1
 <p>LAN cable (10m) (included in the coin box)</p>	1	 <p>AC power cord (3P: approx. 3m) (included in the coin box)</p>	1
 <p>Pop set (instructions included)</p>	1	<p>For pop installation</p>  <p>Screw A</p> <p>cross recessed truss head screw (M6 x 15L)</p>	4
<p>For pop installation</p>  <p>Washer</p> <p>A Flat washer Nominal size 6 (D20 T1.6)</p>	4	<p>SERIAL NO.</p>  <p>Security plug (black)</p>	1

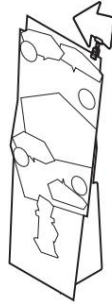
Accessories

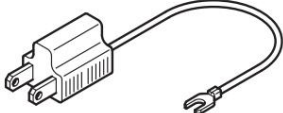
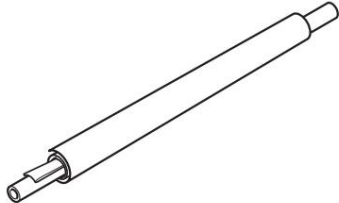
Please check that all accessories are included.

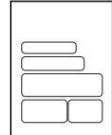
Product Name	Quantity	Product Name	Quantity
Instruction manual (this manual)	1	 Coin Label	1
Warranty card (attached to the protective bag of the main unit)	1		
Microsoft Software License Terms (Please read the terms carefully and keep them together with the instruction manual in a safe place.)	1		
 Hexagonal wrench (2.5mm)	1	 Leaflets (50 pieces)	2
 - It is engraved with "N5000". Maintenance key	2	 Leaflet stand (with instructions)	1
 Coin Door Lock	2	 Separate pop set (instructions included)	1
 Hard Disk Drive Keys	2		
 3P-2P conversion plug (included in the coin box)	1	 Flag (instructions included) • Pole not included. Please use your own pole.	1
 IC Card Reader Information Label : Check the attachment position by referring to page 200 Please do.	1	 PASELI Seal (Do not use if you do not use the PASELI service)	1

Things to prepare for installation

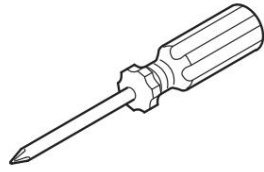

⊕ Drivers (#2 and #3)



Grounding strap (required to prevent static electricity accidents when handling equipment)

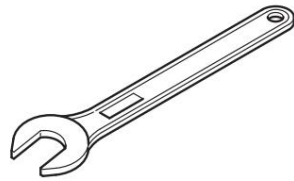

Spanner (24mm)
(Necessary to fix the adjuster)

3. e-AMUSEMENT Service

30 3 e-AMUSEMENT Service

e-AMUSEMENT PASS

What is e-AMUSEMENT PASS? e-AMUSEMENT PASS is a

common pass issued by our company for use with amusement machines. It refers to our company's IC cards or mobile phones registered as e-AMUSEMENT PASS, and these are collectively referred to as e-AMUSEMENT PASS. Things that can be used as e-

AMUSEMENT PASS:

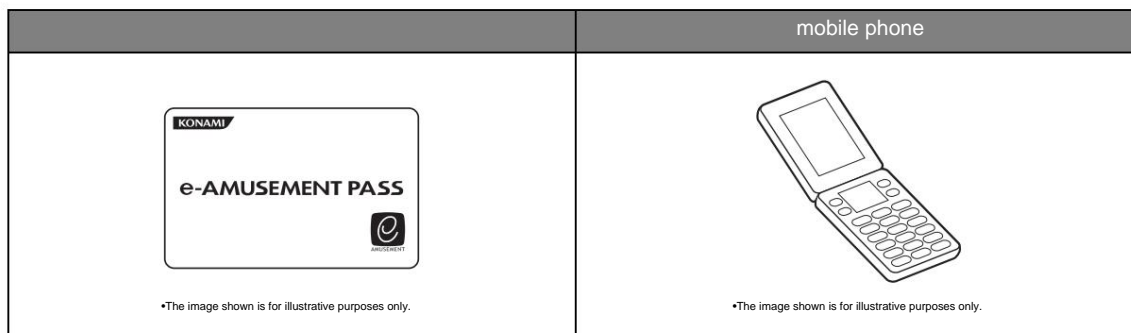

* In addition to the conventional e-AMUSEMENT PASS (our IC card), you can also register your mobile phone as an e-AMUSEMENT PASS.

Not all mobile phones are supported. Any mobile phone that supports electronic money can be registered as an e-AMUSEMENT PASS. Only mobile phones that can be read by the IC card readers built into our game consoles can be registered as an e-AMUSEMENT PASS. (If the card cannot be read, try unlocking the IC card on the mobile phone.) When registering a mobile phone as an e-AMUSEMENT PASS, only the fixed ID on the IC chip built into the mobile phone is used. This does not affect any records written in the mobile phone or electronic payments.

About e-AMUSEMENT PASS

When used with e-AMUSEMENT PASS compatible game consoles, you can save play information, etc. I will come.

The e-AMUSEMENT PASS used with this product cannot be used with other e-AMUSEMENT PASS compatible products. *Even if the game console is manufactured by our company, it may not be compatible with mobile phones.

Be sure to record your card number (user code).

If you change your mobile phone or if your mobile phone or our IC card is damaged, you can transfer your data to a new e-AMUSEMENT PASS by recording (writing down, etc.) the card number (user code). What is a card number (user

code)? - A string of 16 letters and numbers

used to identify an e-AMUSEMENT PASS. (It is displayed on the screen for registering a PIN or authenticating a PIN) - With our IC cards, the same string of characters as displayed on the game console is engraved on the back of the card. - In the case of a mobile phone, check the screen of the game

console. If the data on an e-AMUSEMENT PASS can no longer

be read, it cannot be restored. plug.

Information regarding e-AMUSEMENT PASS is provided at e-AMUSEMENT GATE.

To order e-AMUSEMENT PASS (our IC card) Follow

Please order from our sales representative using the model number below.

<p>e-AMUSEMENT PASS (our IC card)</p>  <p><small>*The image shown is for illustrative purposes only.</small></p>	<p>GUF18-JA (100 sheets) This is a common IC card exclusively for our e-AMUSEMENT PASS compatible products.</p>
---	---

About play information

- You can inherit and use the gameplay information from "Ubeat Knit" and "Ubeat Copios" saved on your e-AMUSEMENT PASS in "Ubeat Copios Append."

PASELI

This product is a PASELI compatible game software.

To use PASELI, please do the following:

What the store does

To use the PASELI service, you must apply to us in advance. (If you are already using the PASELI service, you do not need to apply again for this product.) After applying, we will notify you separately of the start date of your PASELI service. After the start date, you can use it on any PASELI-

compatible game machine connected to e-AMUSEMENT. Even after the start date, you will not be able to use

PASELI in the following cases.

- When the e-AMUSEMENT service is not available due to a network failure, etc.
- When the e-AMUSEMENT service or PASELI service is undergoing maintenance.

Please set the play fee in PASELI in test mode. (Page 87)

If a game using PASELI is interrupted by a power outage, you can provide service to the player. The service button on the service

panel cannot provide service to PASELI, so you must use the test mode.

Go to VIRTUAL COIN SUPPLY. (Page 90)

*PASELI settings are consolidated in VIRTUAL COIN in test mode.

(Page 86)

What the player does

Players must complete the following in advance (via a computer or mobile phone). * If you have a new e-AMUSEMENT PASS

(immediately after purchase), you must first register your PIN on the e-AMUSEMENT compatible game machine, then complete the following steps.

- Get a KONAMI ID (free) •Register e-AMUSEMENT PASS to your KONAMI ID (free) •Set up e-AMUSEMENT PASS for use with PASELI (free)
- Charge PASELI to your KONAMI ID (charges apply)

After completing the above, please play using your e-AMUSEMENT PASS. While playing, your PASELI balance will be displayed at the bottom of the screen.

For inquiries and further information

If you have any questions regarding PASELI contracts or operations, please contact our sales representative.

For more information about PASELI, please visit the following website.

KONAMI's electronic money PASELI (Parsley) From
your PC or mobile phone
<http://paseli.konami.jp/>

● About PASELI Card

What is the PASELI Card?

● A PASELI card is a prepaid card that can be used to charge your PASELI. ● When you scratch off the scratch area on the back of the card, an 18-digit charge code will appear. ● You can use this code to charge your KONAMI ID.

Features and Handling

● PASELI cards can only be used to recharge PASELI.
 ● You cannot play PASELI-compatible games directly with a PASELI card.
 In addition to charging your KONAMI ID, you will need to set up your e-AMUSEMENT PASS to use PASELI. (For details, go to <http://paseli.konami.jp/> from your computer or mobile phone.)
 ● The "****P" written on your PASELI card will be charged at once.
 ● PASELI cards cannot be reissued, refunded, exchanged, etc. ● Do not use them for any purpose other than selling them to players.

Expiration date : There

is no expiration date for uncharged (unused) PASELI cards. The validity period for charged PASELI is one year from the date of last use or charge.

vinegar.

About orders

● A PASELI card is not included with this product. Please order the following model number from our sales representative.
 So lame.

<p>PASELI card /1000P</p>  <p><small>•The image shown is for illustrative purposes only.</small></p>	<p>GUKA9-JA (50 PASELI cards included)</p> <p>One PASELI card can hold 1000P. You can charge your PASELI.</p>
---	---

4. Names of parts

36 4 Names of each part

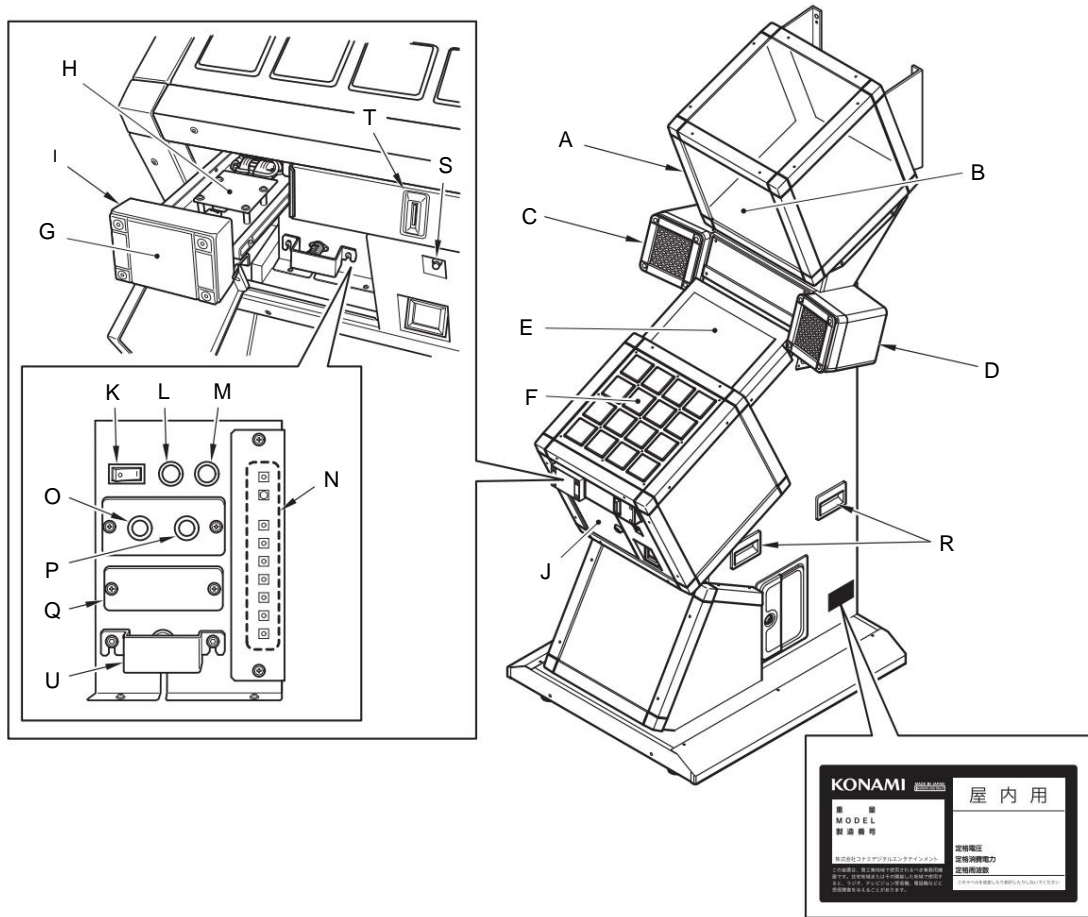

A	Title Unit
B	Title Panel
C	Left speaker
D	Right speaker
E	LCD display
F	Panel (16 pieces)
G	e-AMUSEMENT PASS reader
H	IC card reader
I	IC card reader unit
J	Service Door
K	Sub Power Switch
L	Test button
M	Service button
N	LCD display adjustment board
O	Speaker volume control knob
P	Woofer volume control knob
Q	Coin counter relocation section
R	Handle
S	Coin return button
T	Coin slot
U	Cover for security plug (black)

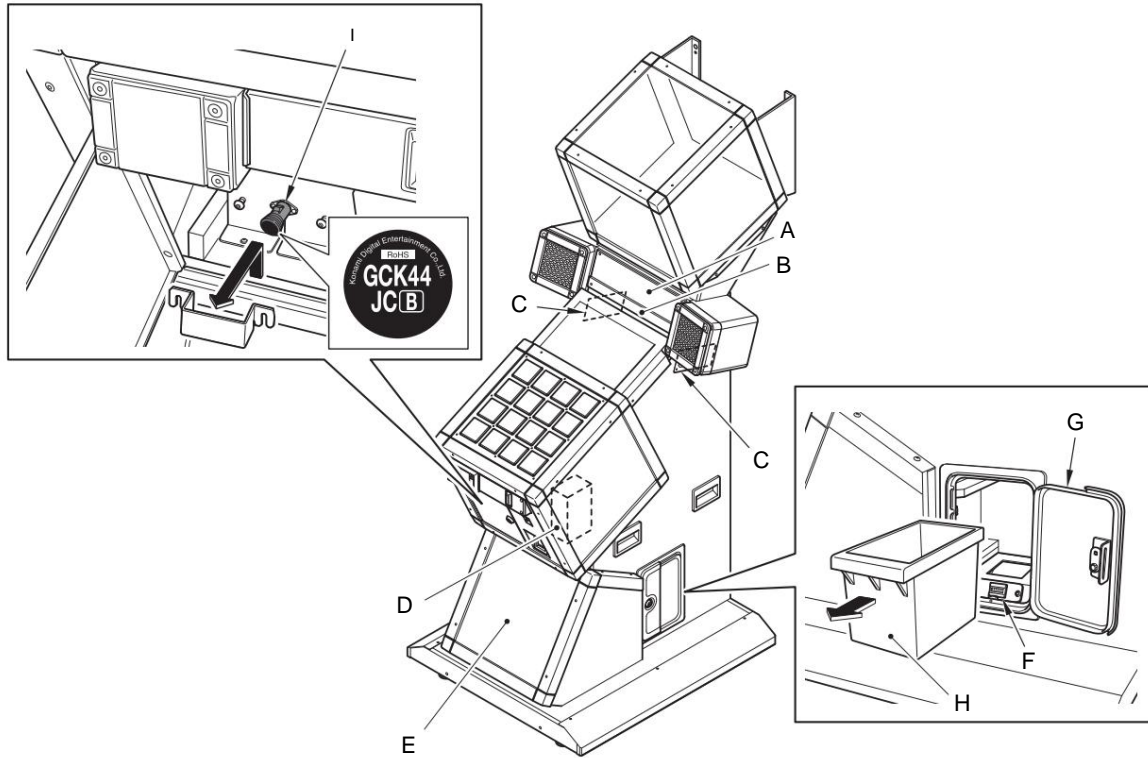

A.	Center Panel
B	Emblem Panel
C	Ventilation hole
D	Coin Selector
E	Woofer
F	Coin Counter
G	Coin Door
H	Coin Box
I	Security plug (black)

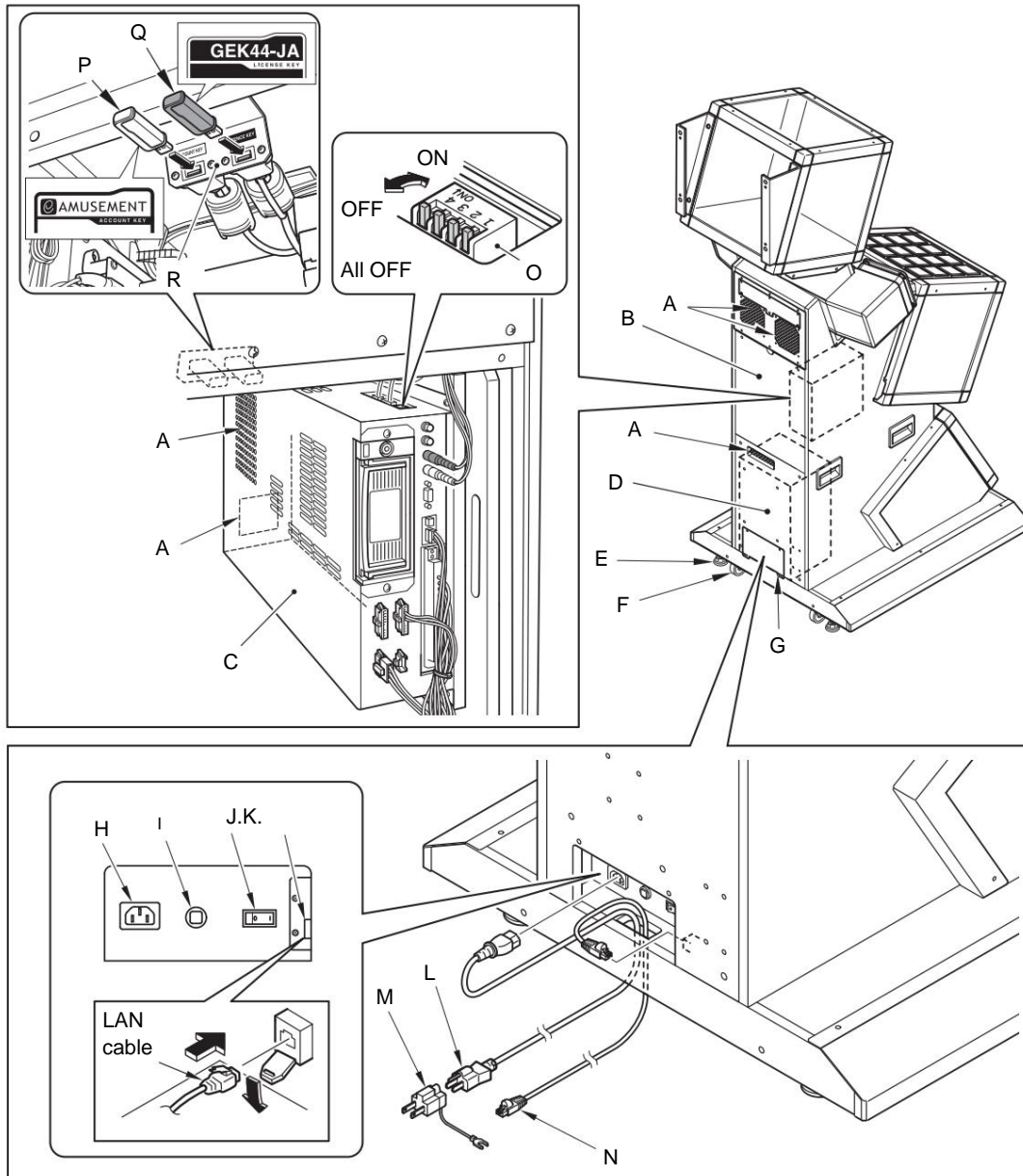

A Ventilation hole	J Main power switch
B Rear door	K LAN Port
C PCB Unit	L AC power cord
D. Power supply unit	M 3P-2P conversion plug
E Adjuster	N LAN cable
F Caster	O Dip Switch
G Power supply unit cover	P Account Key (white)
H Power Inlet	Q License key (black)
I Circuit protector (8A)	R USB bracket

Power Supply

The power supply unit is located on the rear of the unit.



• Always use the included AC power cord. • If you are unable to connect to earth using the 3P power plug, use the included 3P-2P conversion plug and be sure to connect to earth. • Never connect the earth wire to a gas pipe, water pipe, or a dedicated telephone earth terminal. • The inside of the unit contains high-voltage parts that are dangerous, so only a technician should open the rear door of the unit.

Do not

remove the rear door. Also, when removing the rear door, be careful not to touch the inside of the unit carelessly.

• When removing the rear door, be sure to turn off the main power switch of the power supply unit and unplug it from the outlet.

• After turning off the power,

wait at least 10 seconds before turning it on again.

Power supply unit cover

(How to open)

Remove the screws shown in the illustration that secure the power supply unit cover on the rear, and then remove the power supply unit cover.

(How to close)

Attach the power supply unit cover and secure it with the screws.

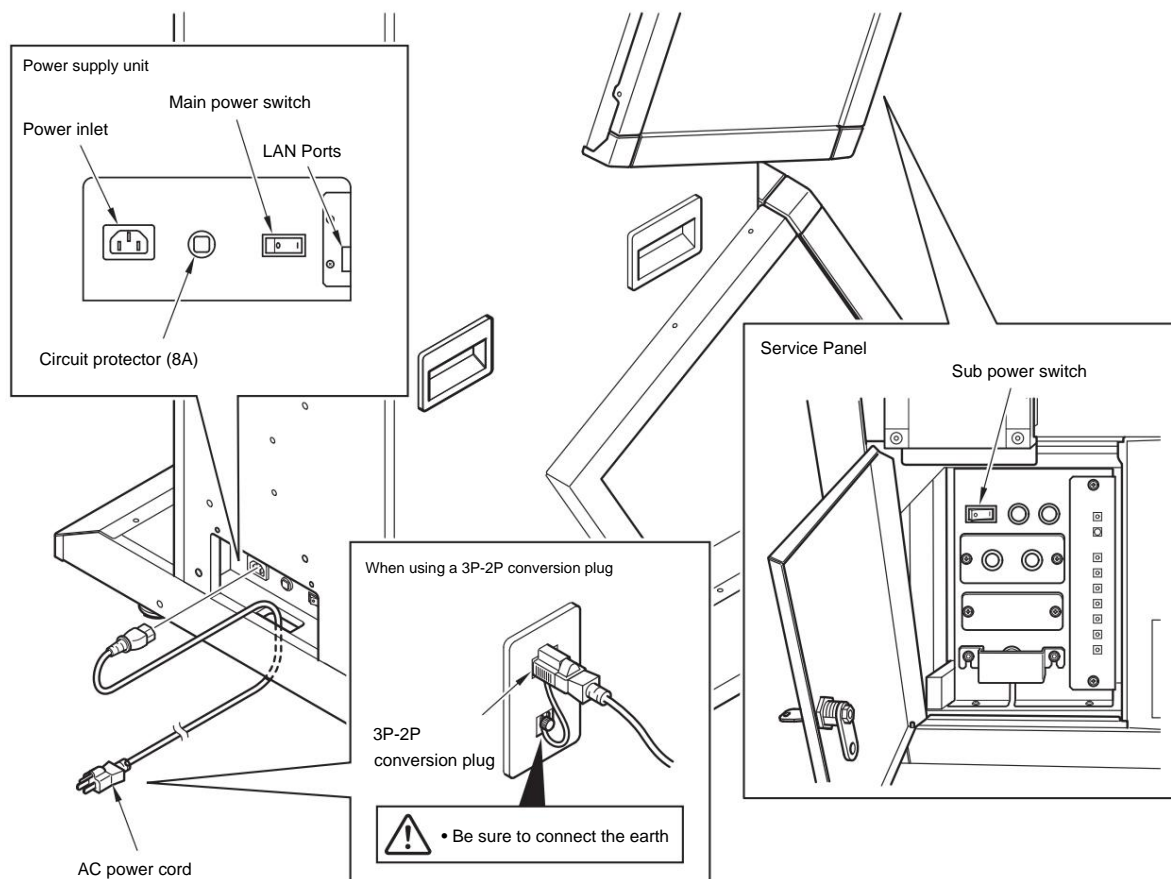
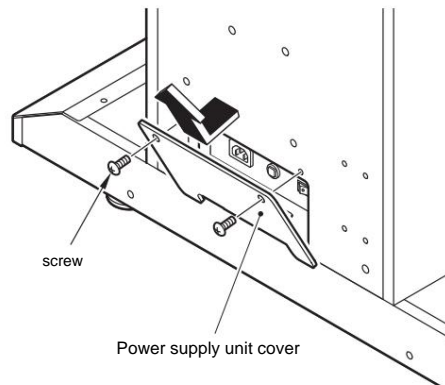

Opening and closing the service door



• When opening the service door, do not apply any weight or impact to the service door. • After closing the service door, be sure to lock it securely.

How to open the service door

1 Open the service door

1. Insert the included maintenance key into the service door and turn it to the right.
2. Open the service door.

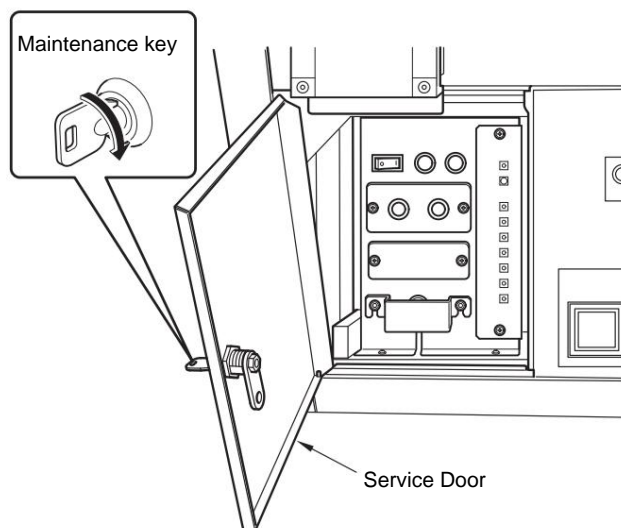

How to close the service door

1 Close the service door

2. Lock it up

- 1 Turn the maintenance key to the left.
2. Remove the key .

Service Panel

About the service panel

When you open the service door, you will find the service panel inside.

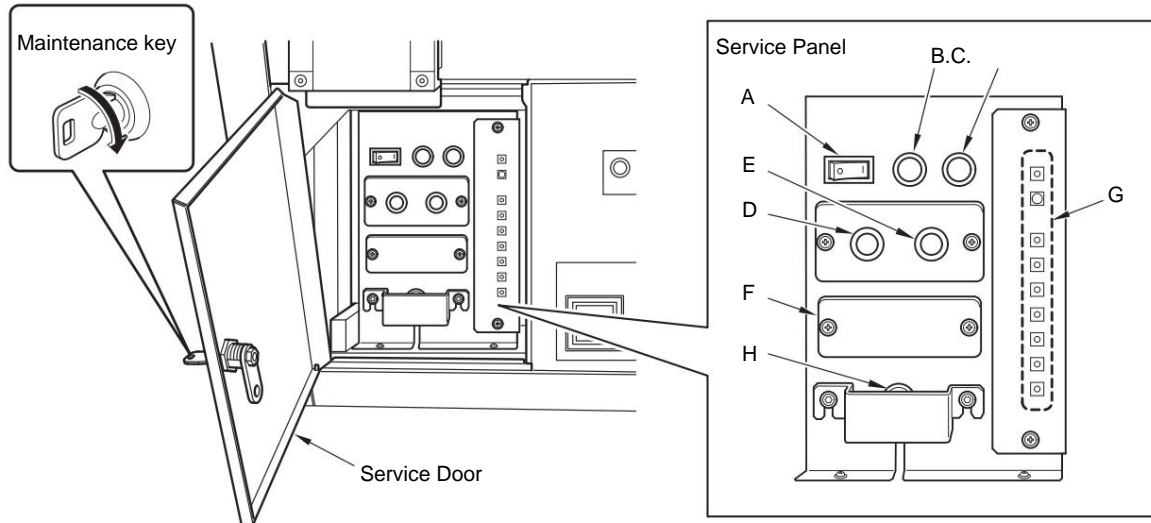

A Sub power switch	This button turns the power on and off. (There are some parts inside the
B Test button	unit that are powered.) Pressing this button in game mode will put the device into test mode. (Page 51) Pressing this button in test mode will toggle between the selected items from top to bottom. (To return to game mode, select "GAME MODE" from "MAIN MENU".) Pressing this button in game mode
C Service Button	will deposit virtual coins and allow you to test play. (The coin counter will not count, and it will not be recorded in the coin tally in "BOOKKEEPING" in test mode. The number of credits relative to the number of coins will be displayed in test mode. The "COIN OPTIONS" settings will be reflected. The current number of coins and credits will also be displayed on the screen.) By pressing this button during test mode, you can confirm the items and settings.
D Speaker volume control knob	You can adjust the volume by turning the knob. To increase the volume, turn right. E
Woofers volume control knob	To decrease the volume, turn left.
F Coin counter relocation section	When relocating the coin counter from inside the coin door, relocate it here. (Page 156) G LCD display
adjustment board	Used when the LCD display needs to be adjusted. (Page 104) Insert the supplied security plug
H security plug (black) socket	(black) here. (Page 139)

Coin door opening and closing



• When opening the coin door, do not apply any weight or impact to it. • Be sure to lock it securely to prevent theft. • When removing coins from the coin box, be careful not to drop them as they can weigh up to 15 kg (3,000 100 yen coins).

•How to open and close the coin door and remove the coin box

Open 1 coin door

1. Insert the coin door key provided into the coin door keyhole and turn it to the right. 2. Open the coin door.

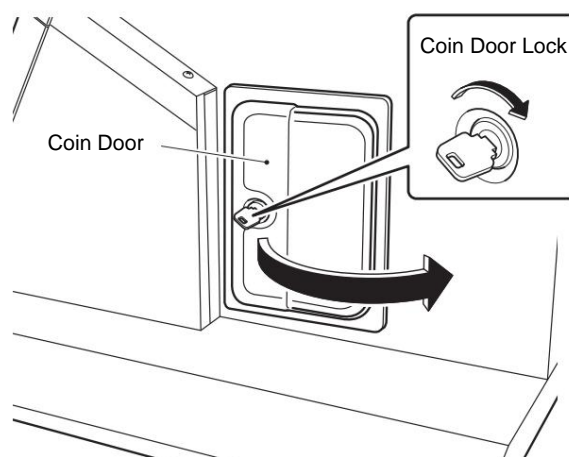

2. Take out the coin box
Remove the coin box.

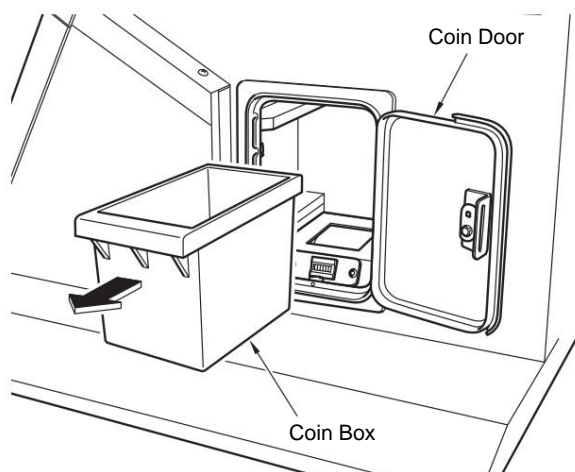

•How to close the coin door

Return 1 coin box

2. Close the coin door

1. Close the coin door. 2. Turn the coin door key counterclockwise and remove it.

☺Coin counter location

When you open the coin door, you will find the coin counter underneath the coin box.

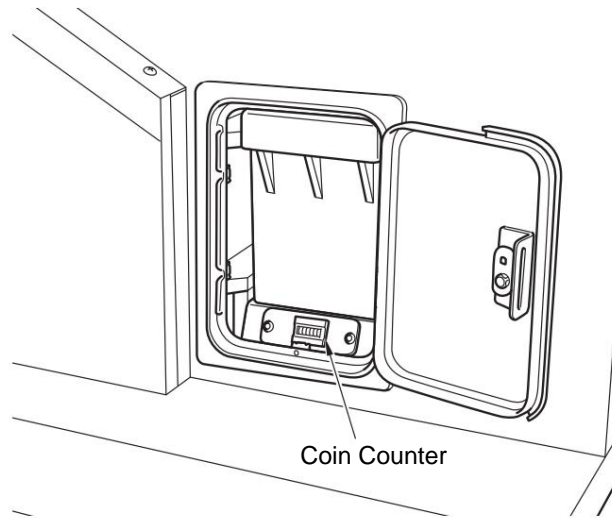

MEMO ☺ The coin counter can be moved to the service panel (☺Page 156).

5How to play

46 How to play

How to play

This game aims to get a high score by touching markers that appear in time with the music.

Game flow

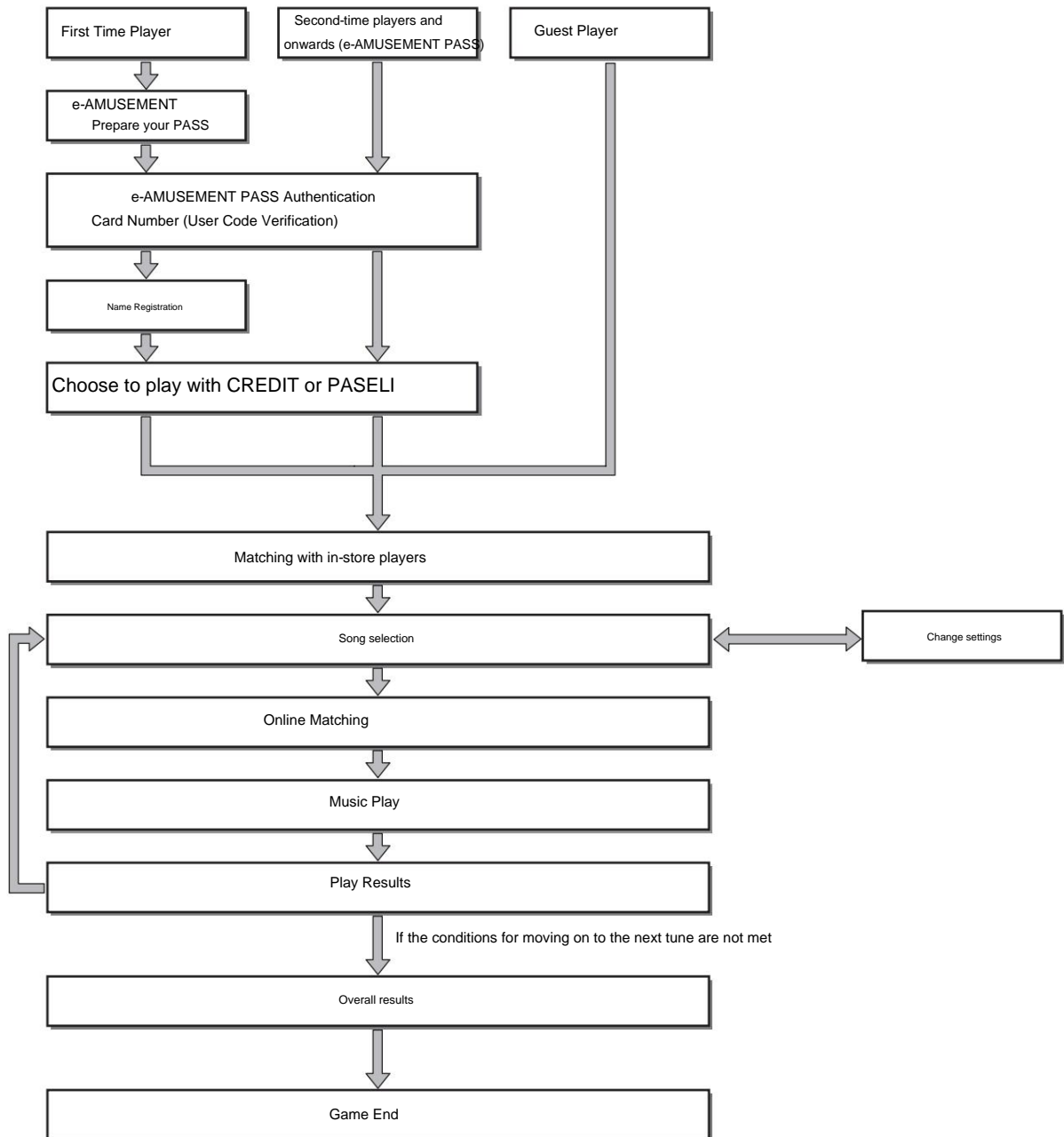

MEMO To match in-store, change the settings in test mode.

You can set up to four machines in "MAX MEMBER (LOCAL)" in "PLAY SETTINGS" under "GAME OPTIONS" (Page 68). Change the setting depending on the number of "Ubeat Copios Append" machines installed in

your store. (Even if multiple "Ubeat Copios Append" machines are installed in the store, the factory setting is for one machine, so matching with players in the store will not occur.)

Matching with "Ubeat Copios" will not be performed.

How to play

1. Insert the coins required to start and touch the panel.

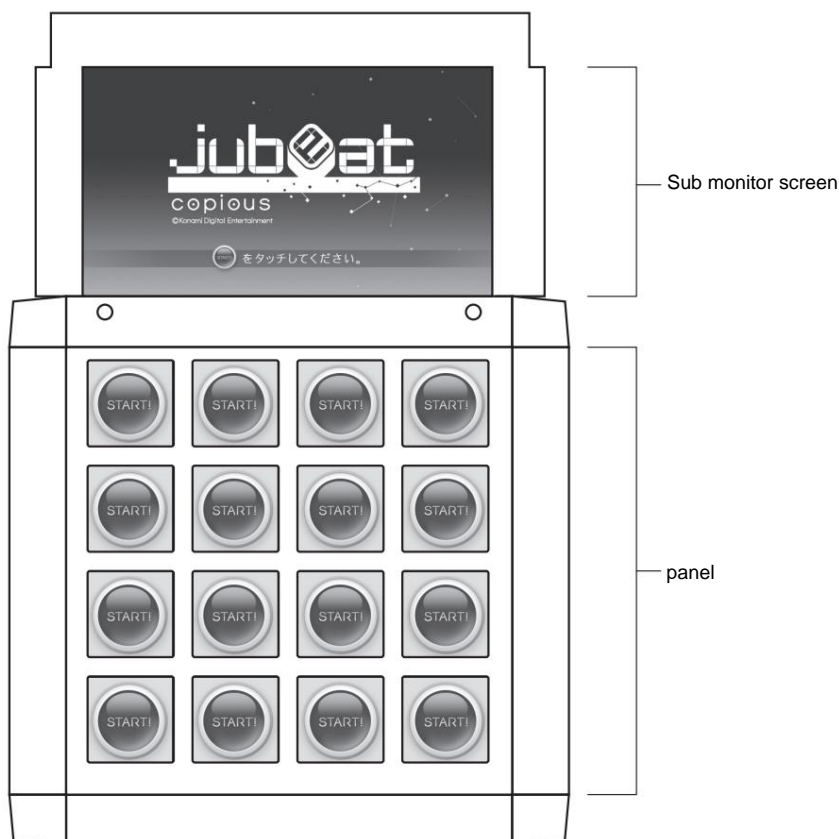

- 2 On the song selection screen, touch the panel that displays the song you want to play, and then touch "NEXT."
Touch the panel to confirm. **3The game starts.**

Touch the panel where the marker appears along with the music. The timing of your touch will affect your score and increase your score. **4If you do not reach 700,000**

points after the end of the game, the game is over .

- * Game Over will not occur in the following cases:
 - The first song of the first play using e-AMUSEMENT PASS
 - The first song of a play without e-AMUSEMENT PASS
 - If multiple people are playing and even one person meets the conditions that prevent Game Over (in that case, no one will get Game Over)

The game is over after playing the set number of **5** songs.

When playing using CREDIT: With the factory settings, you can play up to 3 songs per play.
(Up to five songs can be set in "MAX TUNE (STANDARD)" in "PLAY SETTINGS" in "GAME OPTIONS") (Page 68)

When playing using PASELI: With the factory settings, you can play up to 5 songs in a row.
(In "GAME OPTIONS", in "PLAY SETTINGS", select "MAX TUNE (USAGE Up to five songs can be set in "PLAYBACK BASED" (page 68) .

How to play using e-AMUSEMENT PASS

With this product, you can continuously record your play information by using the "e-AMUSEMENT PASS" (a function exclusive to e-AMUSEMENT).

MEMO You can play without using the e-AMUSEMENT PASS, but your play information will not be recorded.

1 Place the e-AMUSEMENT PASS over the reader.

2 For new e-AMUSEMENT PASS

- Follow the instructions on the screen to register

a new number. Touch the panel with the numbers displayed to register a PIN. (You cannot register a 4-digit number such as "5555")

Register your name.

Insert the coins required to start and touch the panel showing "NEXT." <For registered

e-AMUSEMENT PASS> Touch the panel

showing numbers and enter your PIN. Insert the coins required to

start and touch the panel showing "NEXT." (At this time, the registered name will be displayed on the screen.)

MEMO When entering the PIN, the numbers displayed on the panel will change randomly.

- If the e-AMUSEMENT PASS cannot be recognized, an error message will be displayed. In that case, please use the correct e-AMUSEMENT PASS again. (If it cannot be read after three tries or the PIN does not match, the display will return to the demo screen.)
- If the store is in an environment where the PASELI service is available, you can use PASELI.

3 Select your favorite mode and play. 4 When

the game ends, your results will be recorded on your e-AMUSEMENT PASS.

About play information

- You can inherit and use the gameplay information from "Ubeat Knit" and "Ubeat Copios" saved on your e-AMUSEMENT PASS in "Ubeat Copios Append."

For details on other game modes, please see the website below.

"jubeat series" special site www.konami.jp/bemani/jubeat

About e-AMUSEMENT GATE e-AMUSEMENT GATE is an e-

AMUSEMENT community site that makes amusement games even more fun.

It is equipped with SNS functions, and you can use your mobile phone, PC, smartphone, etc. to communicate with other users on group bulletin boards, etc. It also provides information about e-AMUSEMENT PASS.

e-AMUSEMENT GATE <http://eagate.573.jp/>

6 Game Settings

506 Game Setting Game Start

Check

• When the power is turned on, a self-test (self-diagnosis test) is performed automatically and the results are displayed on the screen. (See "Self-test Results" below.) If the power does not turn on, check that both the main power switch and the sub power switch are turned on. (•Pages 39 and 41)



After turning on the power switch, do not touch the panel until the game demo starts.

- If the abnormal condition continues or the product does not operate normally, immediately turn off the main power switch, unplug the power cord from the outlet, and contact the after-sales service center.
- After turning off the power, wait at least 10 seconds before turning it on again.

• Before turning on the power for the first time after installation

• Please refer to "Installation 5 Confirmation of e-AMUSEMENT Service Use" to confirm the use of e-AMUSEMENT service. (•Page 145)

• Settings immediately after installation, after initialization, etc.

• Immediately after installing this product, moving it, initializing it, or reinstalling it, be sure to adjust and reset the following items.

- Enter store information "GAME

OPTIONS >> SHOP

SETTINGS" (•Page 69)

MEMO: You cannot select "GAME MODE" or "EVENT MODE" until you have set "SHOP NAME SETTINGS" and "SHOP AREA".

- Setting the number of communication devices within the store

"GAME OPTIONS >> PLAY SETTINGS >> MAX MEMBER (LOCAL)" (•Page 68) - Checking network settings and communication status

"NETWORK OPTIONS" (•74 pages)

• Self-test results

If everything is normal, the system will automatically switch to Game Mode and start the game demo. (It will take about 3 minutes from when you turn on the power until the game demo screen appears.) If an error screen appears, refer to "11 Troubleshooting" (•Page 183) for the solution.

Please do so.

Game content settings and adjustments

Manually check or change various settings related to the screen display and game content.

How to start test mode

1 Turn on the power

Turn on the main power switch and sub power switch to start up the unit (Page 39, Page 41) .

2 Press the test button

1 While in game mode, press the test button on the service panel (page 52) .

The MAIN MENU will be displayed on the 2nd screen.

How to exit test mode

1. Select a game mode

Touch the "U" or "D" panel (page 52) to select "GAME MODE" on the MAIN MENU screen.

2 Touch the "ENTER" panel.

do

The screen will go into game mode and the game demo will begin.

MEMO If the items below are not set, the message PLEASE SET "SHOP SETTINGS" will be displayed and you will not be able to exit test mode, so be sure to set them.

"GAME OPTIONS >> SHOP SETTINGS

- SHOP NAME SETTINGS (Store name settings) •
- SHOP AREA (Registration of area)

If you change the settings in "NETWORK OPTIONS," a message may appear when you return to game mode, prompting you to restart the system. If this happens, turn off the main power switch, wait 10 seconds or more, and then turn the power back on.

Buttons (panel) used in test mode

Service Panel

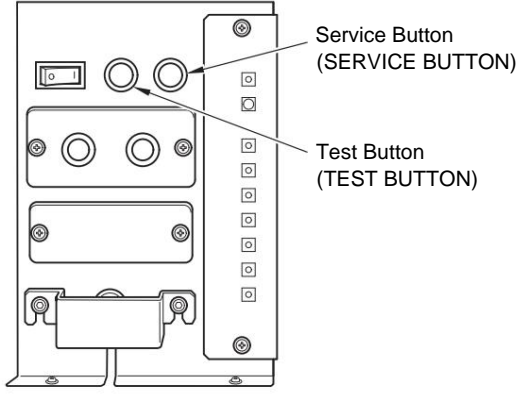



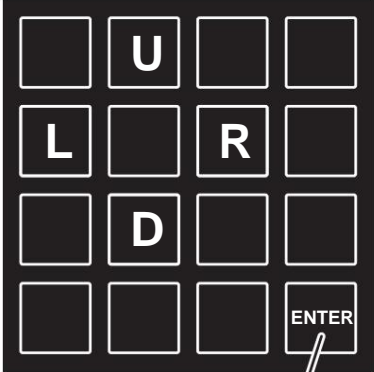

panel



ENTER
or
EXIT

•The above screen display is an example.

	Change the setting value for items that have settings.
	Selects a menu item.
	Changes, confirms, executes, and terminates settings.
	Return to the previous screen.

Explanation of each menu item

MAIN MENU screen

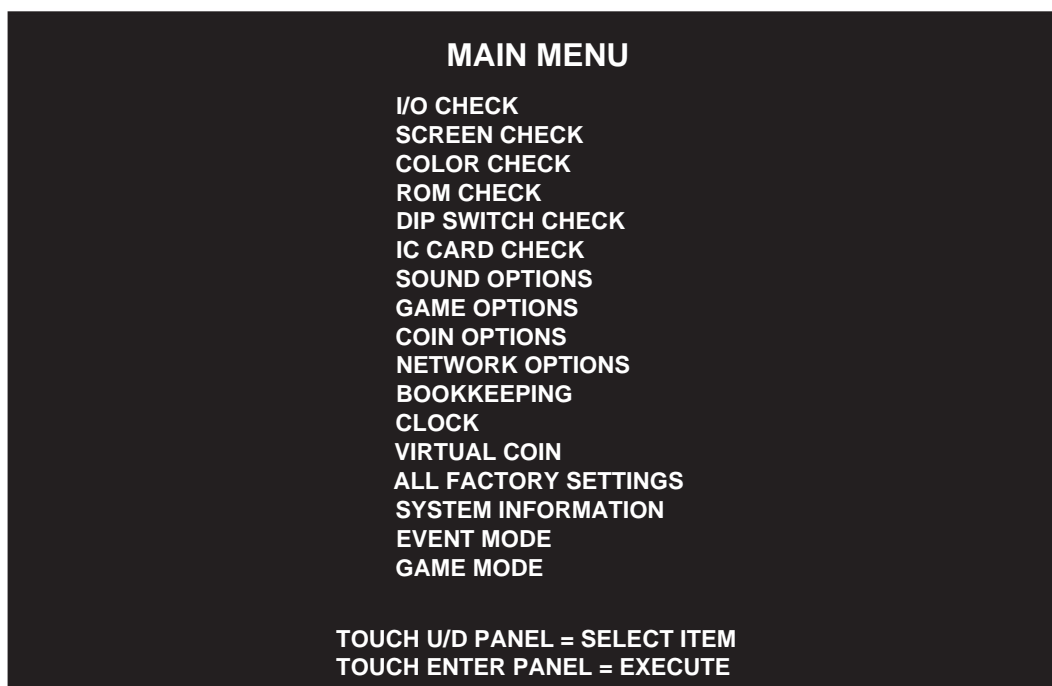

I/O CHECK	Check input/output devices	(Page 55)
SCREEN CHECK	Check the screen size, etc. Check the color	(Page 61)
COLOR CHECK	display on the screen Check	(Page 62)
ROM CHECK	the data contents on the hard disk	(Page 63)
DIP SWITCH CHECK	Check the setting status of the DIP switch	(Page 64)
IC CARD CHECK	Check the operation of the IC card reader Check the status of e-AMUSEMENT PASS	(Page 65)
SOUND OPTIONS	Sound related settings	(Page 66)
GAME OPTIONS	Game settings Coin settings	(Page 67)
COIN OPTIONS		(Page 73)
NETWORK OPTIONS	Checking network settings and communication status	(Page 74)
BOOKKEEPING	Viewing aggregated data about coins	(Page 79)
CLOCK	Setting the current time	(page 85)
VIRTUAL COIN	PASELI settings and checking aggregated data	(Page 86)
ALL FACTORY SETTINGS	Restoring the factory settings	(Page 99)
SYSTEM INFORMATION	Viewing information about the system	(Page 101)
EVENT MODE	Start operation in event mode Return	(Page 102)
GAME MODE	to game mode.	

Select a menu item U or D Touch the panel

Confirming a menu item After selecting an item, touch the ENTER panel.

For detailed explanations of each menu item, please read the reference pages above.

Menu items with setting values

For menu items with set values, the factory default setting is displayed in green, and the changed setting is displayed in red.

When you want to

change the setting value, touch the U or D panel to select the item, and then touch the L or R panel to change it. After

changing the setting value, select "SAVE

AND EXIT" and touch the ENTER panel.

The settings are automatically saved and the message "NOW SAVING" is displayed, and the display returns to the MAIN MENU screen. If

you select "EXIT" after changing the settings, the following message is displayed.

YOU HAVE NOT SAVED YET.

SAVE CHANGES NOW? YES / NO •Touch the U or D panel

to select "YES/NO", then touch the ENTER panel to confirm.

If you select "YES", the settings will be saved and the message "NOW SAVING" will be displayed, and the screen will automatically return to the MAIN MENU screen.

If you select "NO", the message "NO MODIFICATION" will be displayed and the screen will return to the MAIN MENU screen without saving any changes.

MEMO If you select "FACTORY SETTINGS" for a menu item that has settings and touch the ENTER panel, all settings for that menu item will be reset to the factory defaults.

I/O CHECK

Checking the input/output devices

ÿ Check the operation of each button, coin selector, panel, coin blocker, etc., and the lamps.
Check that the light is on.

"I/O CHECK" item selection screen

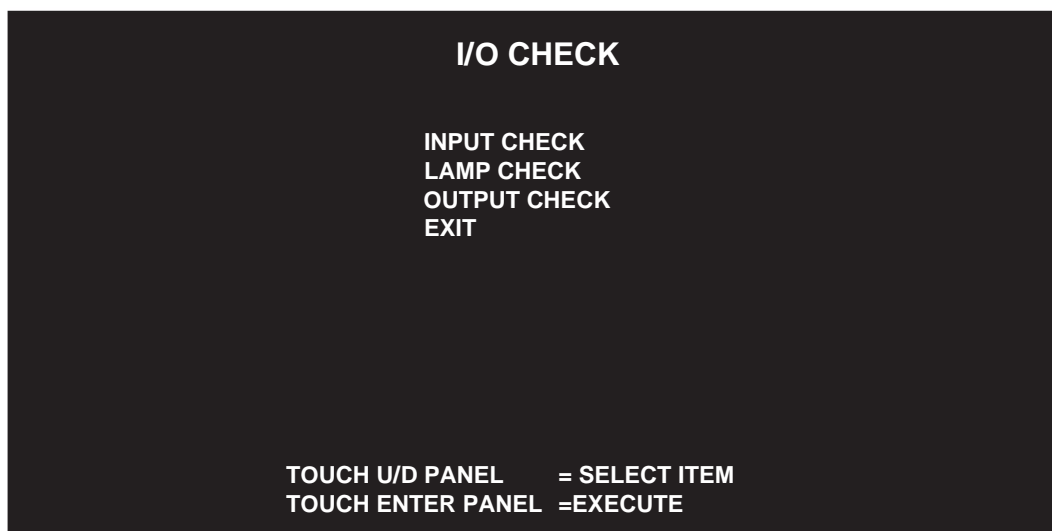

INPUT CHECK	Checking input for each button, panel, and coin selector (ÿPage 56)	
LAMP CHECK	Check that the lights are on (ÿPage 58)	
OUTPUT CHECK	Checking the operation of the coin blocker (ÿPage 60)	

Selecting an item

Touch the U or D panel.

Deciding on the item

After selecting an item, touch the ENTER panel.

Return to MAIN MENU Select "EXIT" and then touch ENTER panel

ÿ For detailed explanations of each item, please read the reference pages above.

I/O CHECK >> INPUT CHECK

Check input of each button, panel, and coin selector

ÿ Check the operation of each button and 16 panels.

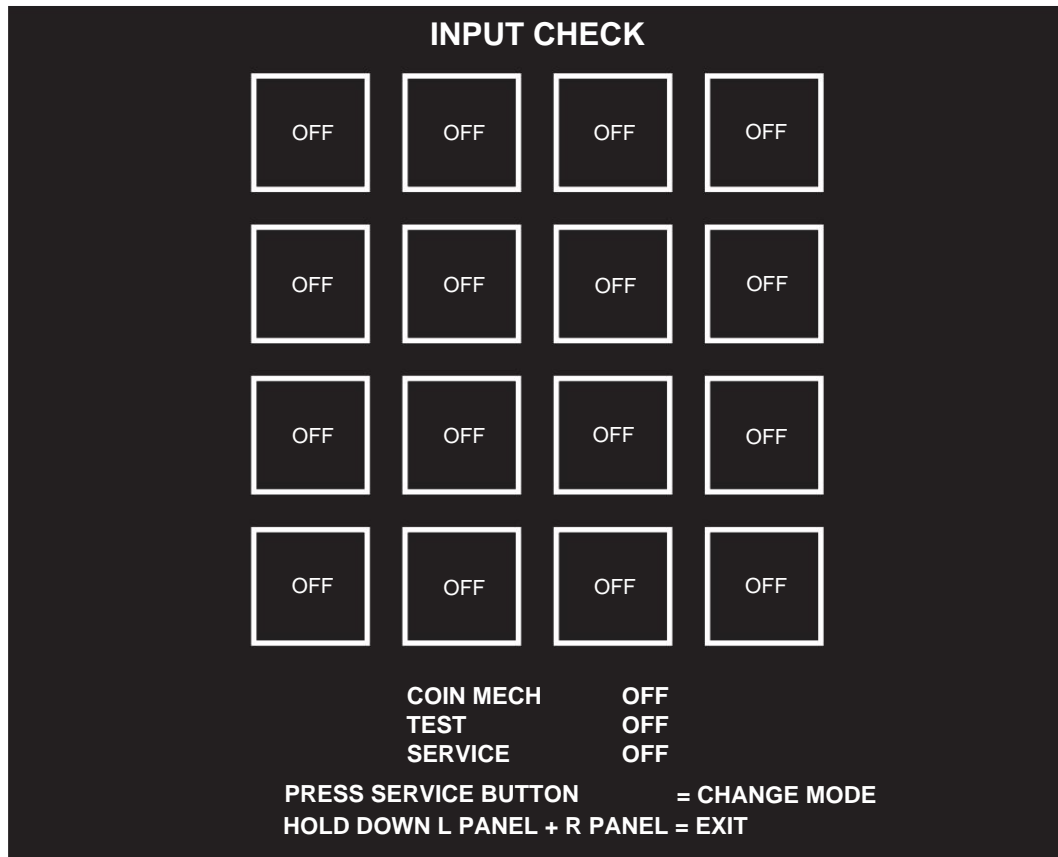

ÿ (There are 16 panels. <small>vinegar</small>)	<p>Displays "ON/OFF" according to the input on each panel.</p> <p>ÿ ON: The switch is on.</p> <p>ÿ OFF: The switch is not turned on.</p> <p>Each panel has four rubber switches at the top left, top right, bottom left, and bottom right. When any of these switches are turned on, the device is "ON."</p> <p>Press the service button to confirm the input of the four rubber switches.</p> <p>The screen will change to one where you can confirm the settings (ÿpage 57) .</p>
COIN MECH	<p>Displays "ON/OFF" depending on coin input.</p> <p>ÿ ON: The switch is on.</p> <p>ÿ OFF: The switch is not turned on.</p>
TEST SERVICE	<p>Displays "ON/OFF" according to the input of each button.</p> <p>ÿ ON: The switch is on.</p> <p>ÿ OFF: The switch is not turned on.</p>

Return to I/O CHECK Touch the R panel while touching the L panel.

Change the check screen Press the service button on the service panel

Position of each button and panel

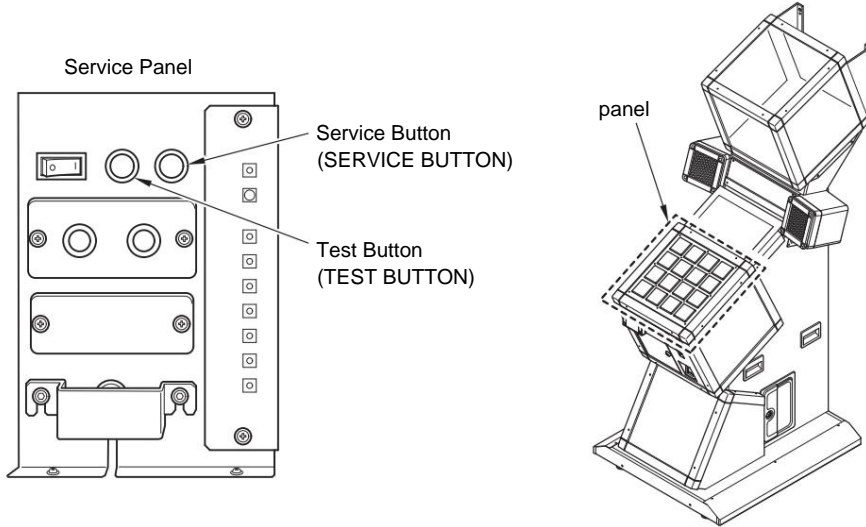

• Check input of 4 rubber switches

Panel 4 Switch Check Screen

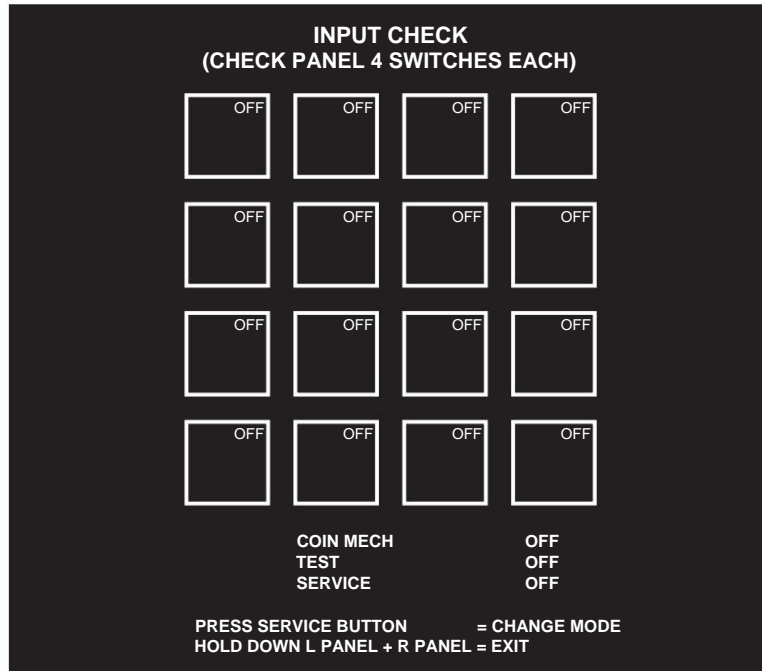

<p>• (There are 16 panels. <small>vinegar</small>)</p>	<p>The four rubber switches on each panel are located at the top left, top right, bottom left, and bottom right. It will display "ON/OFF" according to the switch input.</p> <p>• ON: The switch is on.</p> <p>• OFF: The switch is not turned on.</p> <p>••••: Not currently being checked.</p> <p>The input status of the rubber switches being checked is displayed in the following order: can be done.</p> <div style="text-align: center;"> </div> <p>Touch the panel to be checked and turn on the four rubber switches. Please check the input status of the switch.</p>
--	--

Return to I/O CHECK Touch the R panel while touching the L panel.

Change the check screen Press the service button on the service panel

I/O CHECK >> LAMP CHECK

Check that the lights are on

ÿ Check that each LED lights up properly.

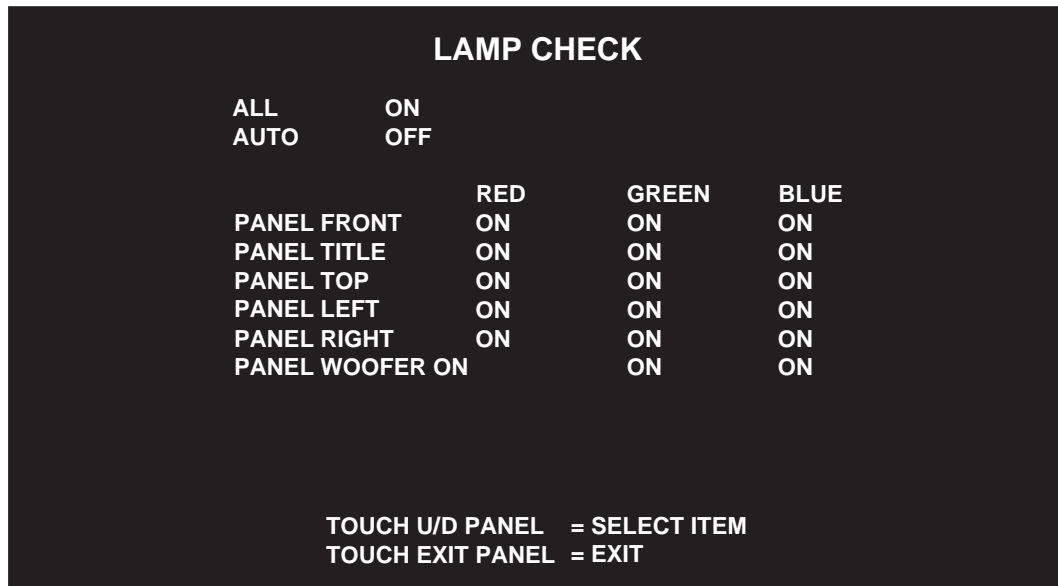

ALL	All LEDs will light up white at the same time.
AUTO	All LEDs turn on in sequence red, green, blue I will. PANEL FRONT RED ÿ PANEL FRONT GREEN ÿ PANEL FRONT BLUE ÿ PANEL TITLE RED • • • PANEL WOOFER BLUE then all LEDs turn white Then PANEL FRONT RED Go back and repeat.
PANEL FRONT RED/GREEN/BLUE PANEL TITLE RED / GREEN / BLUE PANEL TOP RED / GREEN / BLUE PANEL LEFT RED / GREEN / BLUE PANEL RIGHT RED / GREEN / BLUE PANEL WOOFER RED / GREEN / BLUE	Select the LED you want to check and the corresponding LED will light up. ÿ ON: Lights up. ÿ OFF: Turns off.

Selecting an item (lit)

Touch the U or D panel.

Return to I/O CHECK

Touch the EXIT panel

LED lighting position

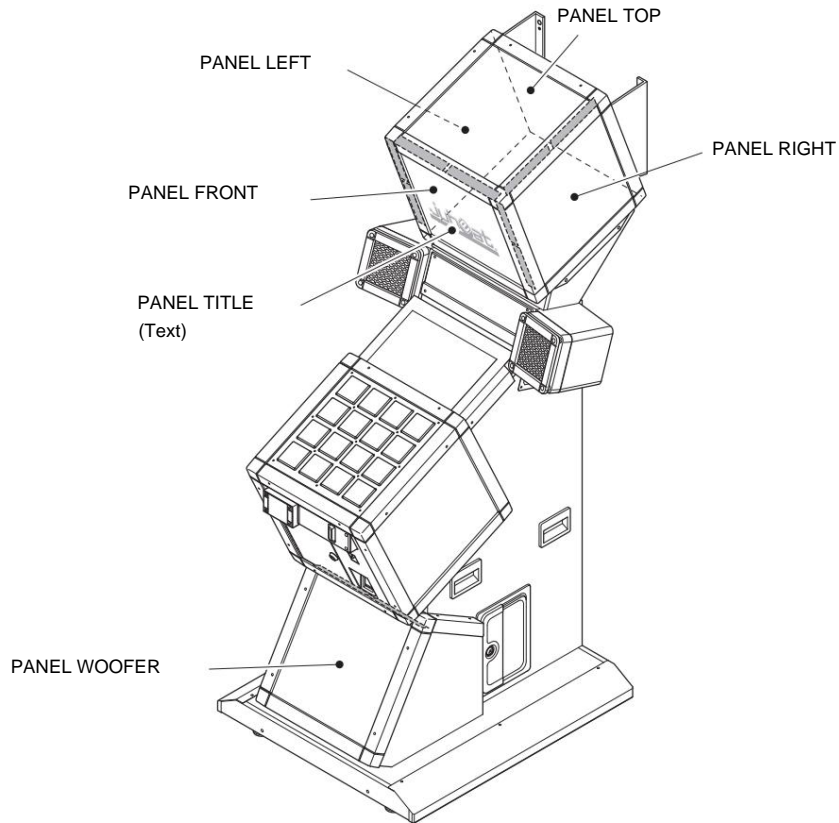

I/O CHECK >> OUTPUT CHECK Checking the

operation of the coin blocker ÿ Check
the operation of the coin blocker.

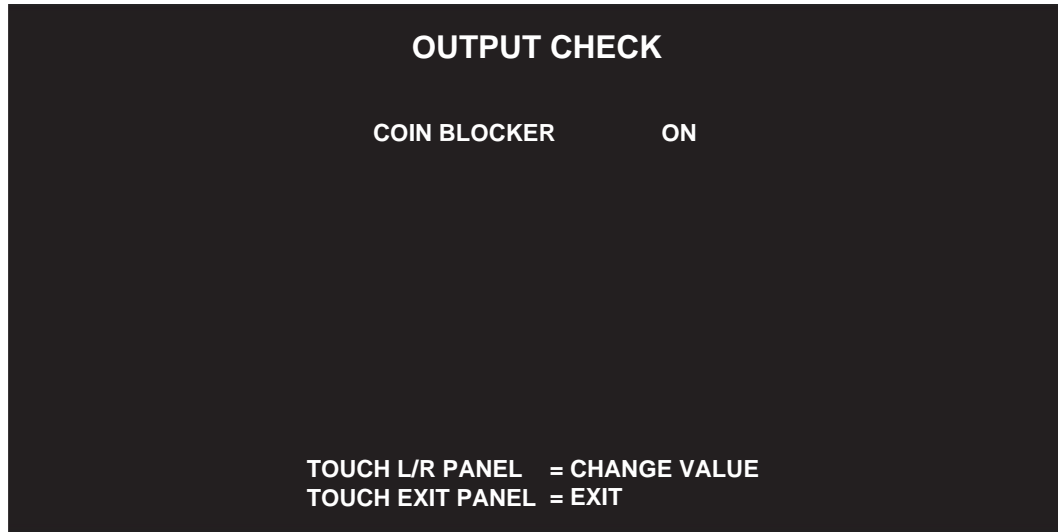

COIN BLOCKER

Check that the coin blocker is working by inserting a coin into the coin slot.

ÿ ON: The coin blocker is activated (coins are returned to the return slot). ÿ

OFF: The coin blocker is not activated.

(Accepts coins and places them in the coin box)

MEMO: Inserting coins into "OUTPUT CHECK" will not count towards "BOOKKEEPING" or the coin counter value.

Operation check

Touch the L or R panel.

Return to I/O CHECK Touch the EXIT panel

SCREEN CHECK

the screen size, etc. Check the screen display.

First, check that the entire red frame is visible on the sub monitor.

Next, in that state, check that the red frame on the panel screen is clearly visible on all 16 panels.

If there is misalignment or

size of the screen, adjust it using the LCD display adjustment board. (Page 105)

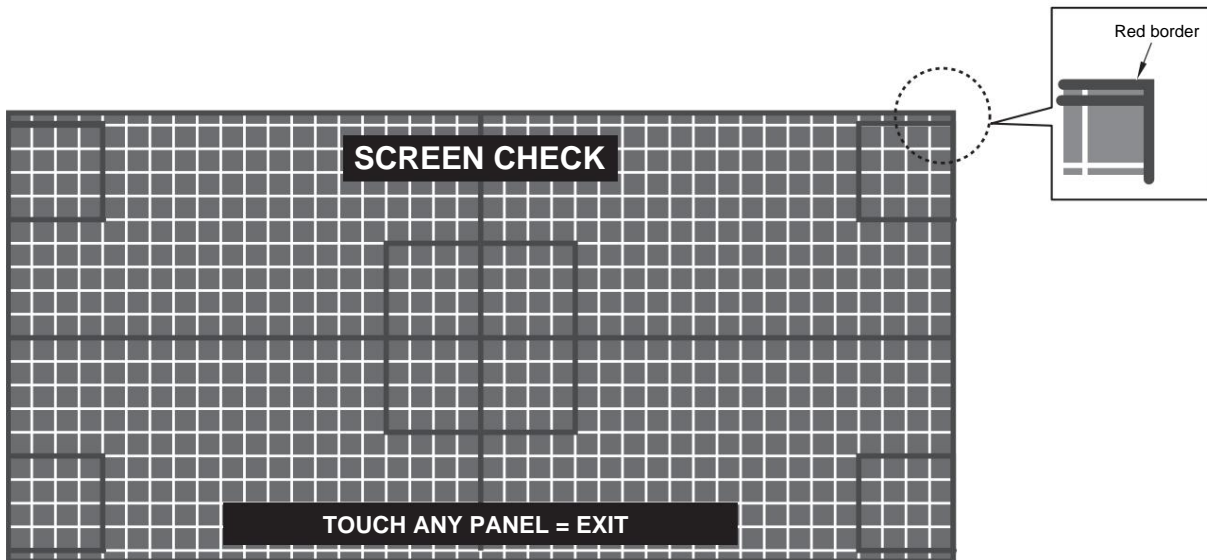

NOTE For details on how to adjust the screen size, vertical and horizontal offset, etc., refer to the OSD menu.

You can do this in "Auto-configure" in the "Screen" item. When

doing so, be sure to do so while the above "SCREEN CHECK" screen is displayed.

Doing

so on another screen may cause the screen position and size to be shifted.

Return to MAIN MENU Touch any panel

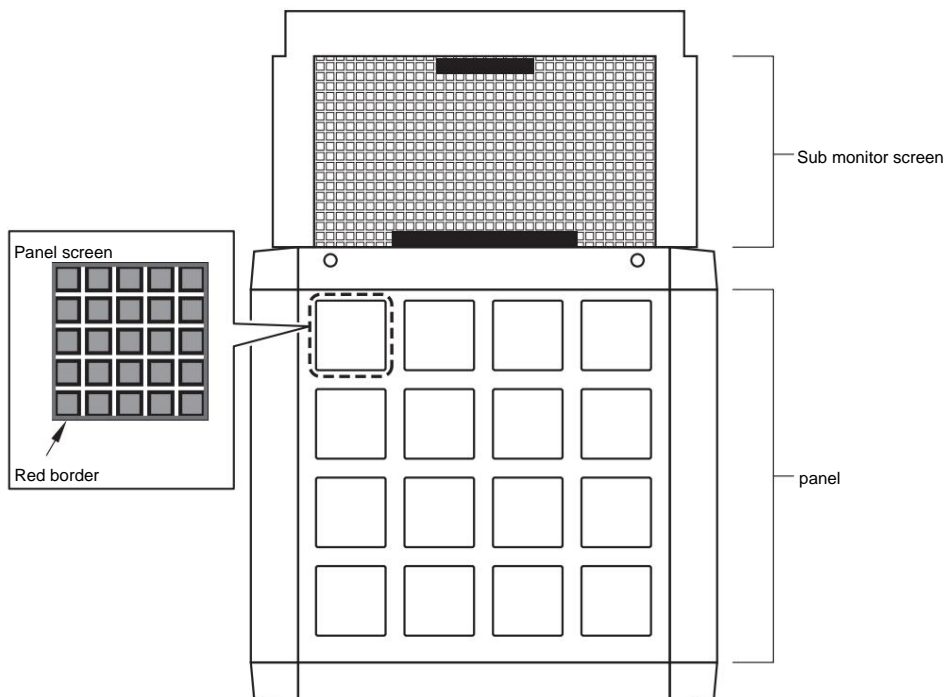

on the screen

Check the color display. Adjust

the LCD display adjustment board so that the color bar is displayed in gradations and the background is sufficiently black (Page 104). In this

case, adjust so that the part of "COLORLESS" at the bottom left of the screen is black.

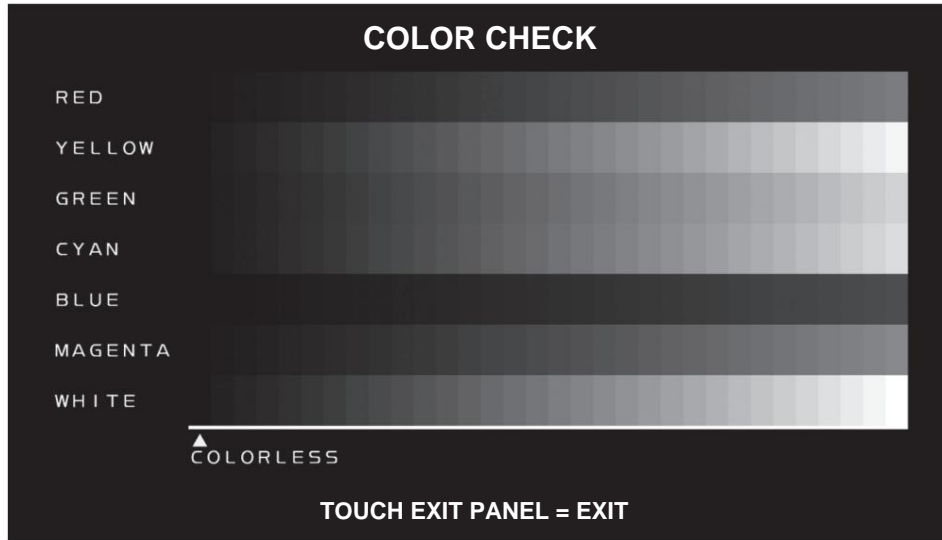

Return to MAIN MENU Touch the EXIT panel

ROM CHECKChecking

the data contents on the hard disk ÿ Checks the data contents on the hard disk.

When you enter this menu item, the check will start automatically. The check will take about 2 minutes. (The check time varies depending on the condition of the hard disk.)

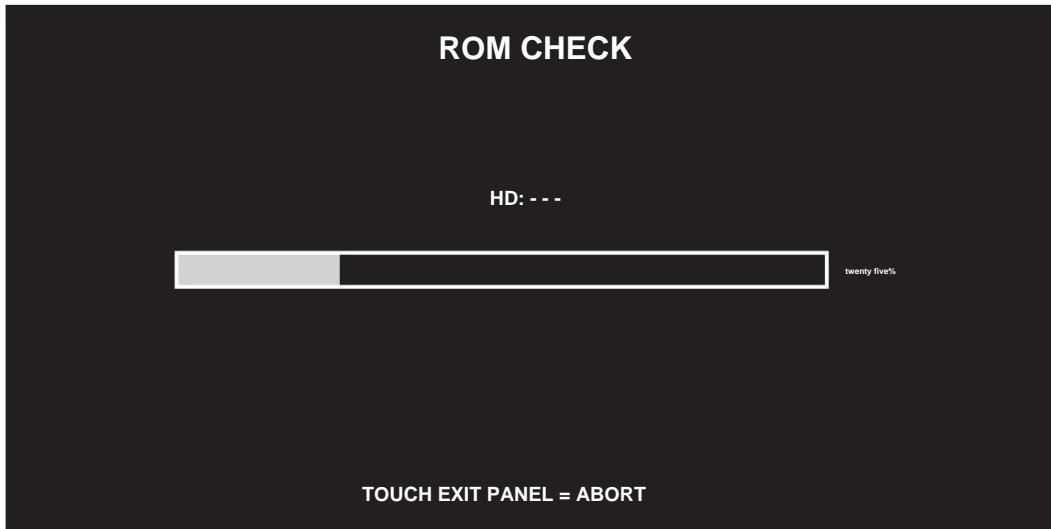
**Progress Bar**

The count starts from 0% and when it reaches 100%, the check is complete. (The figure shows an example where the check is at 25%.) The progress bar is displayed in gray during the check. If an abnormality is found, it turns red.

"---" will be displayed while checking.

HD: --- If

the check result is normal, "OK" will be displayed in green.

HD: OK

If the check reveals an abnormality, "BAD" will be displayed in red.

HD: BAD

MEMO ÿ If "BAD" is displayed, turn off the main power switch, wait 10 seconds or more, then turn the power back on and check again. If "BAD" is still displayed, immediately turn off the main power switch, unplug the power cord from the outlet, and contact our after-sales service center.

Stop the check

Touch the EXIT panel.

"ABORTED" will be displayed and the display will return to the "MAIN MENU" screen.

Return to MAIN MENU Touch EXIT panel after checking is complete

DIP SWITCH CHECK

Checking the DIP switch settings

ÿ Check the dip switch settings.

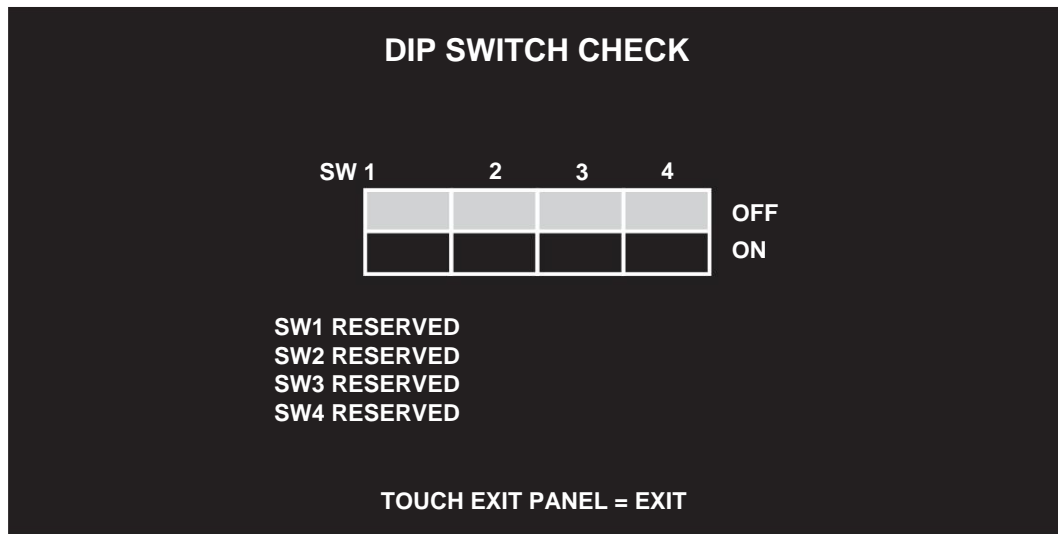

SW1
SW2
SW3
SW4

Displays the "ON/OFF" status of the DIP switch.
ÿ ON: The switch is on.
ÿ OFF: The switch is not turned on.

NOTE: Unless otherwise instructed by our company, always use the dip switches according to the settings in the table below. please.

* See page **38** for the location of the dip switches .

ÿ If the settings differ from those in the table above, the following message will be displayed on the screen.

**CHECK YOUR SETTINGS AND OPERATE
DIP SWITCHES ON THE PCB.**

Return to MAIN MENU Touch the EXIT panel

IC CARD CHECK

Check the operation of the IC card reader and the status of the e-AMUSEMENT PASS

ÿ Check the e-AMUSEMENT PASS and confirm that the IC card reader is working.

An e-AMUSEMENT PASS is required to check the operation of the IC card reader.

Please check by holding the e-AMUSEMENT PASS against the reader.

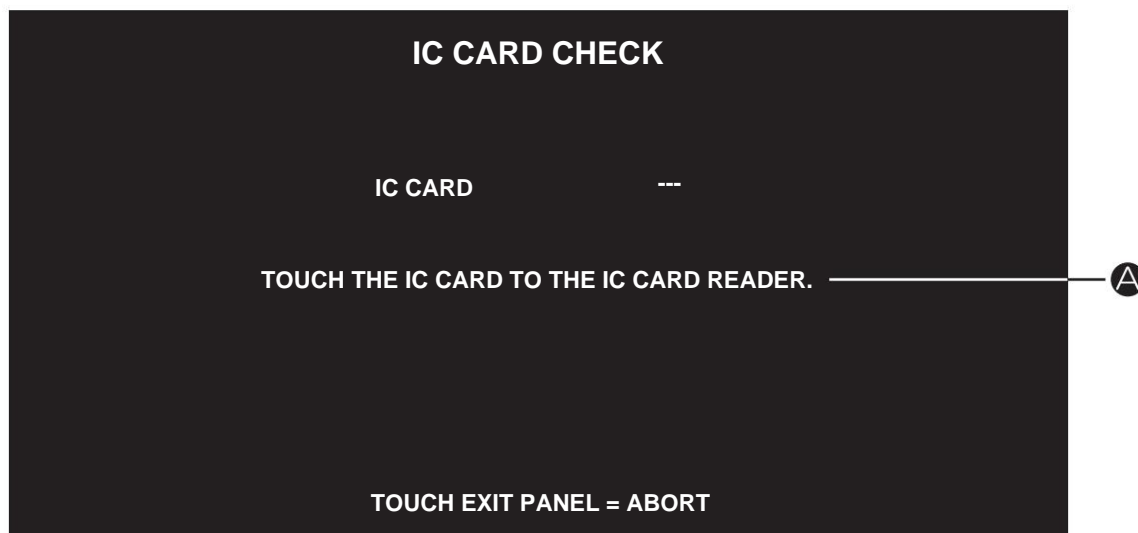

IC CARD	<p>Displays the status of e-AMUSEMENT PASS.</p> <p>ÿ OK[*]: e-AMUSEMENT PASS was recognized. Depending on the type of e-AMUSEMENT PASS recognized [*] will display a number.</p> <p>---: e-AMUSEMENT PASS cannot be recognized or read. Nothing is assigned to the department. If "---" is displayed no matter how many times you tap, try another Check it out by winning the e-AMUSEMENT PASS.</p>
---------	--

MEMO ÿ For details about e-AMUSEMENT PASS, please refer to "e-AMUSEMENT PASS" on page 30.

Ⓐ As the check progresses, the display will change as shown below.

ÿ Initializing

INITIALIZING

ÿ IC card reader connection check failed

NOT AVAILABLE

ÿ When the check is interrupted

ABORTED

Stop the check

EXIT Touch the panel

- "ABORTED" will be displayed and you will return to the "MAIN MENU" screen.

Return to MAIN MENU Touch EXIT panel after checking is complete

SOUND OPTIONS

Sound Settings

ÿ Configure and check sound settings.

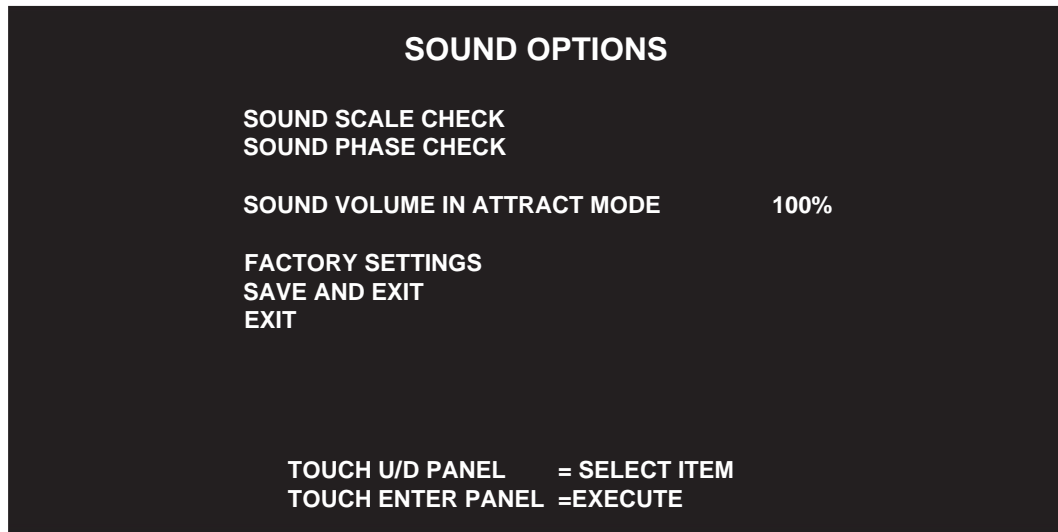

SOUND SCALE CHECK	Balanced sounds are played in the background music. "Do-re-mi...do" is played in the left speaker. It alternates between the car and right speaker. Select "LEFT/RIGHT" to see which speaker is playing. It will be displayed.
SOUND PHASE CHECK	Check the speaker polarity. ÿ Stand about 1.0m away from the speaker and face the panel from the front. I will confirm. ÿ LOUD: Produces a loud sound. SOFT: A soft sound is produced.
SOUND VOLUME IN ATTRACT MODE (Factory setting: 100%)	Set the volume during game demo to 0% (silent) compared to the volume during gameplay. Adjust in 10% increments from 100% (maximum). ÿ To turn the volume down or up, press the L or R panel. Please touch.
FACTORY SETTINGS	ENTER Touch the panel to enter the setting for this menu item. will return to the factory settings.
SAVE AND EXIT	You can change the settings or restore the factory settings in "FACTORY SETTINGS". Even if you change it back to the setting, the setting will not be reflected unless you confirm this item. plug.

Selecting an item

Touch the U or D panel.

Change settings

After selecting an item, touch the L or R panel.

Back to MAIN MENU

Select "SAVE AND EXIT" or "EXIT" and then press the ENTER button. Touch the

GAME OPTIONS

Game Settings

ÿ Enter game settings and store information.

"GAME OPTIONS" item selection screen

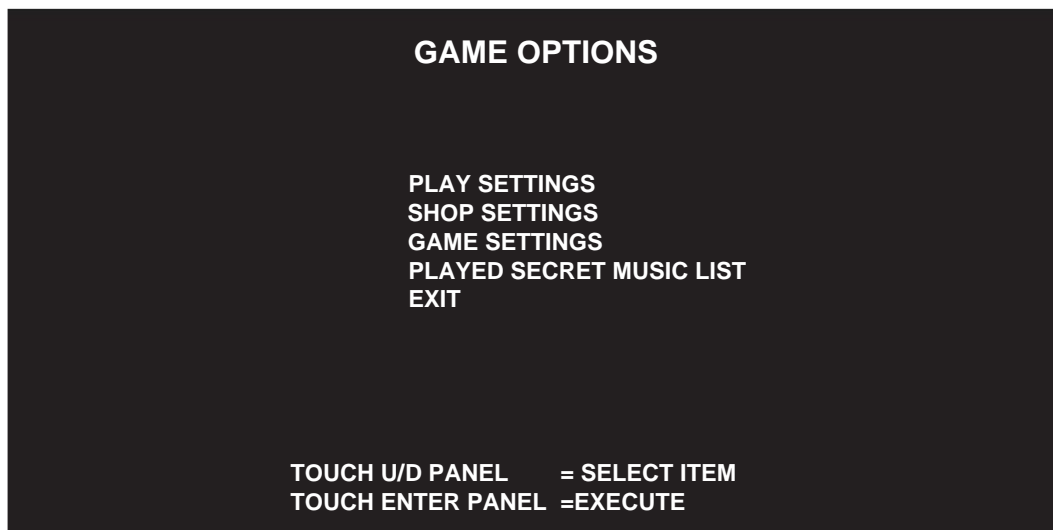

PLAY SETTINGS Play settings		(ÿPage 68)
SHOP SETTINGS Enter store information		(ÿPage 69)
GAME SETTINGS Closing settings		(ÿPage 71)
PLAYED SECRET MUSIC LIST	View a list of unlocked songs played	(ÿPage 72)

Selecting an item

Touch the U or D panel.

Deciding on the item

After selecting an item, touch the ENTER panel.

Return to MAIN MENU Select "EXIT" and then touch ENTER panel

ÿ For detailed explanations of each item, please read the reference pages above.

GAME OPTIONS >> PLAY SETTINGS

Settings related to play ý

Set the settings related to play.

"PLAY SETTINGS" item selection screen

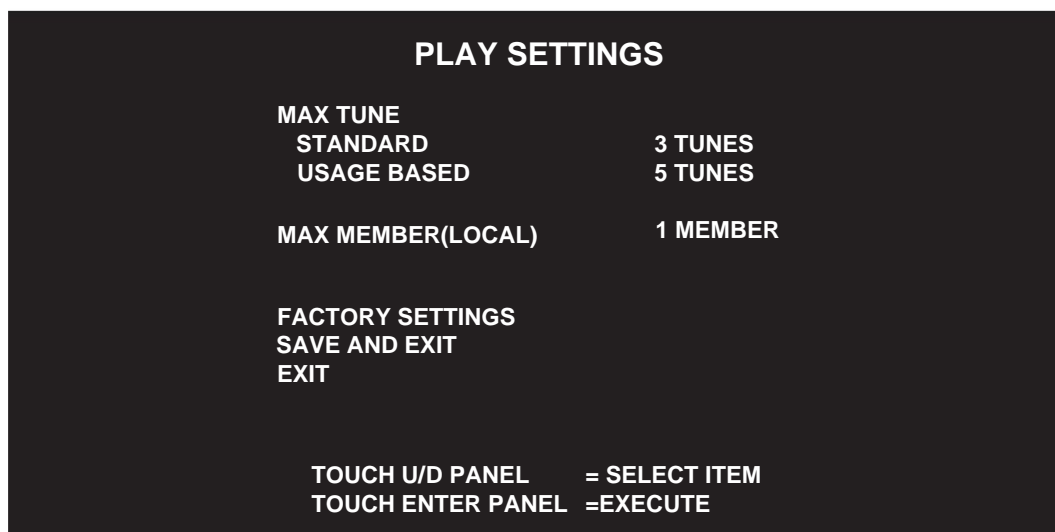

MAX TUNE STANDARD (Factory setting: 3)	Sets the maximum number of songs you can play when selecting play with CREDIT. (5 levels: 1TUNE to 5TUNES)
MAX TUNE USAGE BASED (Factory setting: 5)	If you pay PASELI according to the number of songs you play, you set the maximum number of songs you can select. (Five levels: 1TUNE to 5TUNES) Set the
MAX MEMBER (LOCAL) (Factory setting: 1)	maximum number of devices that can communicate within the store. (4 levels: 1MEMBER to 4MEMBERS)
FACTORY SETTINGS ENTER TOUCH	Touch the panel to change all the settings of this menu item. Even if you change settings or restore the
SAVE AND EXIT	factory settings in "FACTORY SETTINGS," the settings will not be reflected unless you confirm with this item.

MEMO ý The factory setting for the number of communication devices in the store, "MAX MEMBER (LOCAL)" is It is set to "1 MEMBER". Please change the setting depending on the number of "Ubeat Copios Append" units installed in your store.

Selecting an item

Touch the U or D panel.

Change settings

Touch the L or R panel.

Back to GAME OPTIONS

Select "SAVE AND EXIT" or "EXIT" and then touch the ENTER panel.

GAME OPTIONS >> SHOP SETTINGS

Enter store information

ÿ Enter store information.

"SHOP SETTINGS" item selection screen

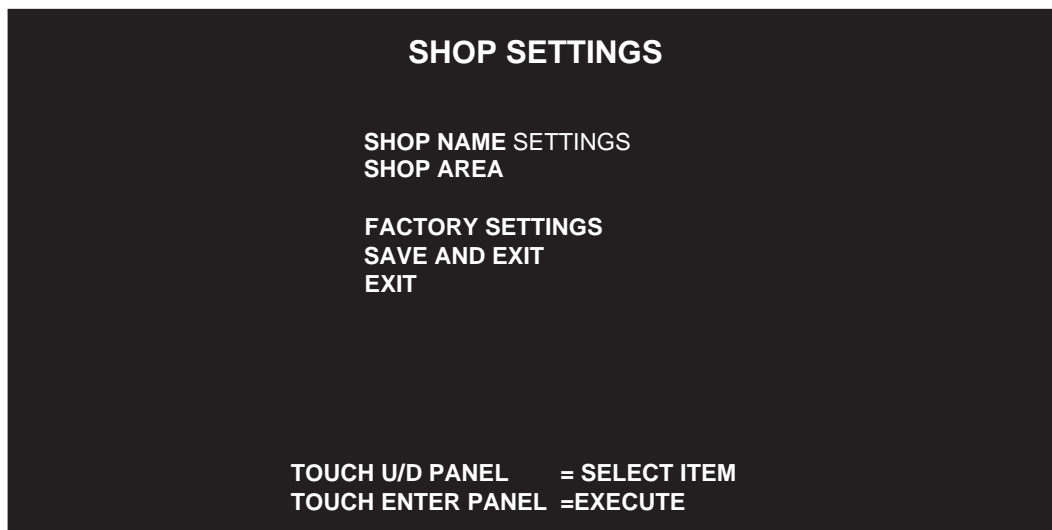

SHOP NAME SETTINGS (Not set at time of shipment)	Registering the store name (ÿPage 70) ÿ Register the name of the store that operates this product. After selecting an item, touch the ENTER panel to display the registration screen. Please do.
SHOP AREA (Not set at time of shipment)	Regional Registration ÿ Register the region in which this product will be operated. To select a region, touch the L or R panel.
FACTORY SETTINGS	ENTER Touch the panel to enter all of the menu items. All settings will be restored to the factory settings.
SAVE AND EXIT	You can change the settings or restore the factory settings in "FACTORY SETTINGS". Even if you return to the previous state, the settings will not be reflected unless you confirm this item. plug.

MEMO ÿ Until you set "SHOP NAME SETTINGS" and "SHOP AREA" "GAME MODE" or "EVENT MODE" cannot be selected.

Selecting an item

Touch the U or D panel.

Change settings

Touch the L or R panel.

GAME OPTIONS
return

Select "SAVE AND EXIT" or "EXIT" and then press the ENTER button.
Touch the

GAME OPTIONS >> SHOP SETTINGS >> SHOP NAME SETTINGS

Store name registration

Register the name of the store where this product will be operated.

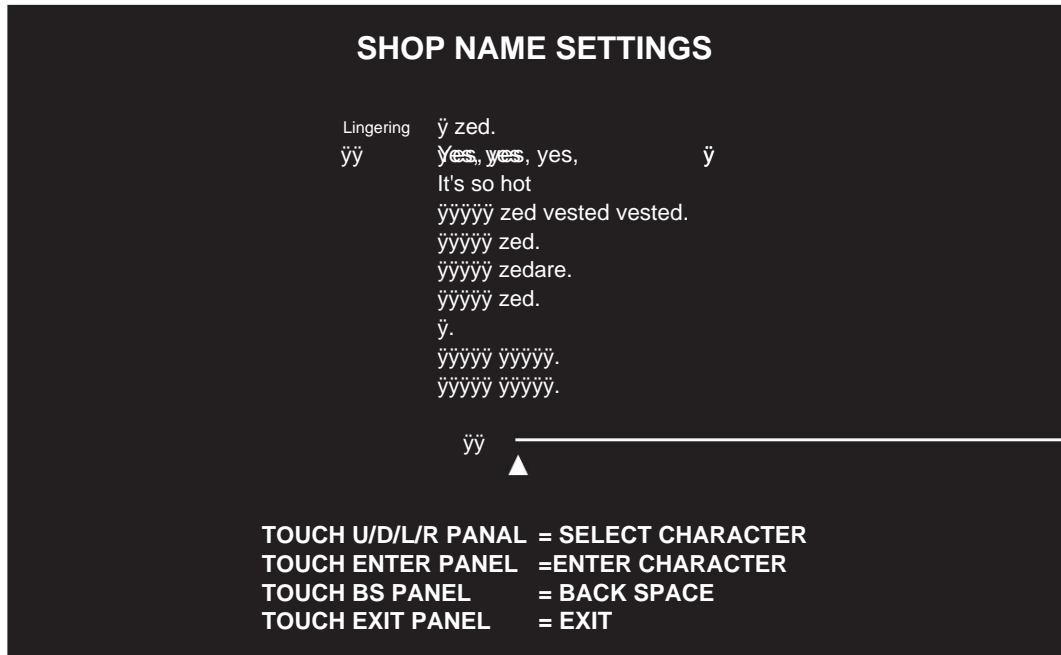

MEMO Register the store name will be displayed on the game screen, so please make sure to register the store name of the store that operates this product.
 Please enter the store name.

How to enter store name

Move the cursor to select characters and input method, then confirm each character to enter the store name.

A : The store name you entered will be displayed.

Store name can be up to 16 characters long.

- | | |
|-------------------------|---|
| Character selection | Touch the U/D/L/R panel
(The selected text will turn red.) |
| Entering characters | ENTER Touch the panel |
| Deleting characters | Touch the BS panel |
| SHOP SETTINGS
return | After entering the store name, touch the EXIT panel. |

GAME OPTIONS >> GAME SETTINGS

Closing settings

ÿ Configure the closing settings.

If you set the time in advance in "CLOCK" on page 85 , you can set the closing time.

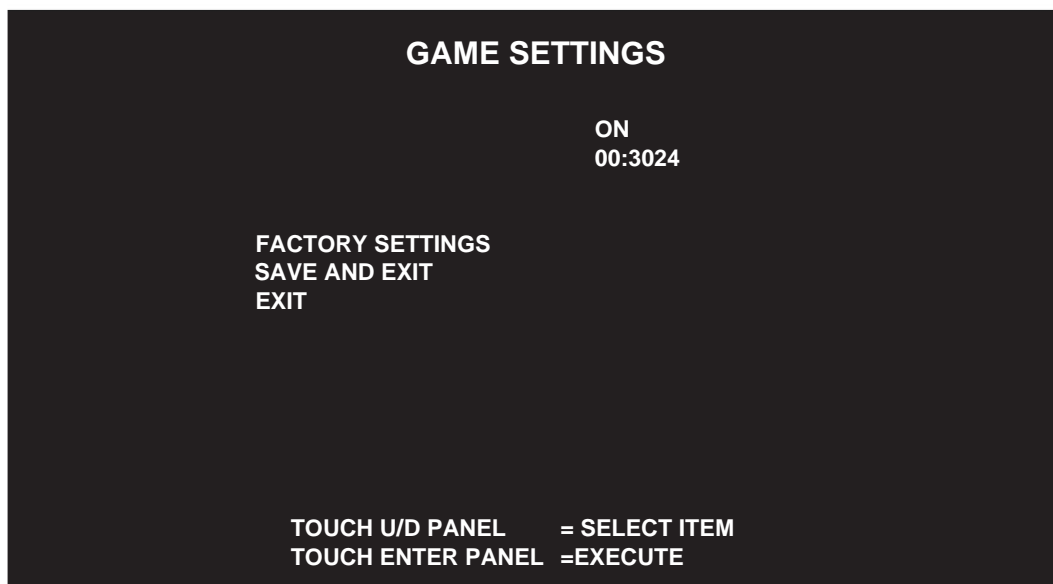

Closing setting (Factory setting: OFF)	Set the closing time display for the store. ÿ OFF: The closing setting is disabled and the closing message is not displayed on the game screen. will not be displayed on the main screen. ÿ ON: The closing setting is enabled and the closing message is displayed on the game screen. The display will be displayed on the main screen.
Closing time	Set the store's closing time (can be set in 5 minute increments). (This item is displayed when the closing setting is set to "ON") 24-hour format Example: 0:30 ÿ To change the time, touch the L or R panel to change the hour and minute. Select and touch the U or D panel to change the time.
FACTORY SETTINGS	ENTER Touch the panel to enter all of this menu items. settings will be restored to the factory settings.
SAVE AND EXIT	You can change the settings or restore them to their factory settings in "FACTORY SETTINGS". Even if you return to the normal mode, the settings will not be reflected unless you confirm this item.

MEMO ÿ If "Closing Setting" is set to "ON", the closing time will start 30 minutes before the time set in "Closing Time".

A message will be displayed on the screen informing you that the store is closing, and new coins will be accepted 15 minutes prior to the closing.

(The set closing time will be
Please restart the game to play later.)

ÿ If the time is not set immediately after installing this product or after initializing it,
When you try to set the "Closing Setting" to "ON", the message "FIRST, SET THE CLOCK.
"CLOCK" ITEM IS IN MAIN MENU." appears, prompting you to set the time.
EXIT Touch the panel to cancel the display, then touch "CLOCK" to set the time.
Please set the time (ÿPage 85) .

Selecting an item	Touch the U or D panel.
Change settings	After selecting an item, touch the L or R panel.
GAME OPTIONS return	Select "SAVE AND EXIT" or "EXIT" and then press the ENTER button. Touch the

GAME OPTIONS >> PLAYED SECRET MUSIC LIST

View a list of unlocked songs played

ÿ Displays a list of unlocked songs that have been played.

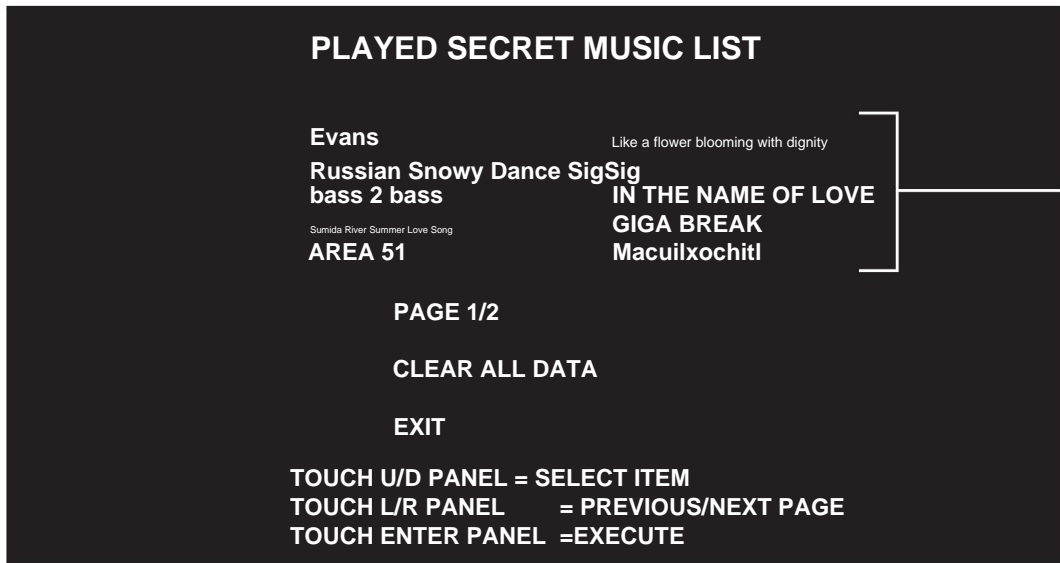

Song Title	A list of the titles of the unlocked songs that have been played will be displayed.
PAGE	The current page number/total page number is displayed. ÿ To move between pages: Touch the L or R panel.
CLEAR ALL DATA	Resets the title list display to the factory settings. ENTER Touch the panel to DO YOU WANT TO CLEAR ALL DATA? YES/NO will be displayed, so touch the U or D panel to select. Please. If you select "YES", you will be asked to confirm again. If you select "YES" again, "NOW ERASING" will be displayed. The data will be erased immediately. If you select "NO", "NOT CLEARED" will be displayed and the data will No data will be erased.

Selecting an item

Touch the U or D panel.

Deciding on the item

After selecting an item, touch the ENTER panel.

GAME OPTIONS
return

Select "EXIT" and then touch the ENTER panel.

COIN OPTIONS

Settings ÿ Set and confirm play fees.



ÿ If you set "FREE PLAY" to "ON", the fee setting item will not be displayed and you will be able to play for free, so please be careful.

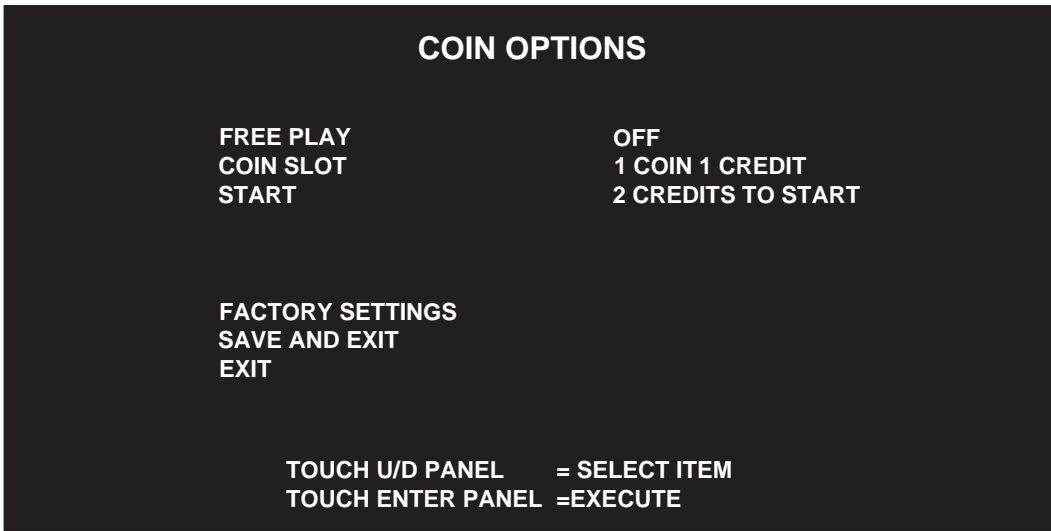

FREE PLAY (Factory setting: OFF)	Set up free play. ÿ ON: Play for free. ÿ OFF: Pay to play. Set the number
COIN SLOT (Factory setting: 1 COIN 1 CREDIT)	of credits per coin. (Can be set from 1 COIN 1 CREDIT to 10 COINS 1 CREDIT) (See table below) Set the
START (Factory setting: 2CREDITS TO START)	number of credits required to start the game. (1 CREDIT TO START ~ 10 CREDIT TO START (Can be set in units of 1 CREDIT) ENTER
FACTORY SETTINGS	Touching the panel will reset all settings of this menu item to the factory default settings. Even if you
SAVE AND EXIT	change the settings or reset them to the factory default settings in "FACTORY SETTINGS", the settings will not be reflected unless you confirm them in this item.

MEMO: If "FREE PLAY" is set to "ON", "COIN SLOT" and "START" will not be displayed. Also, the PASELI service will not be available.

Selecting an item

Touch the U or D panel.

Change settings

After selecting an item, touch the L or R panel.

Back to MAIN MENU

Select "SAVE AND EXIT" or "EXIT" and then touch the ENTER panel.

Coin to credit pattern

pattern	1	2	3	4	5	6	7	8	9	10	11	12	13						
Number	1	1	1	2	2	3	4	5	6	7	8	9	10						
of coins Number of credits	1	2	3	1	3	1	1	1	1	1	1	1	1						

NETWORK OPTIONS

Checking network settings and communication status

ÿ Check the network settings and communication status of each unit connected to the network.

I am.

After connecting to the network, be sure to check the ID settings and communication status of the connected device in this item. please.

"NETWORK OPTIONS" item selection screen

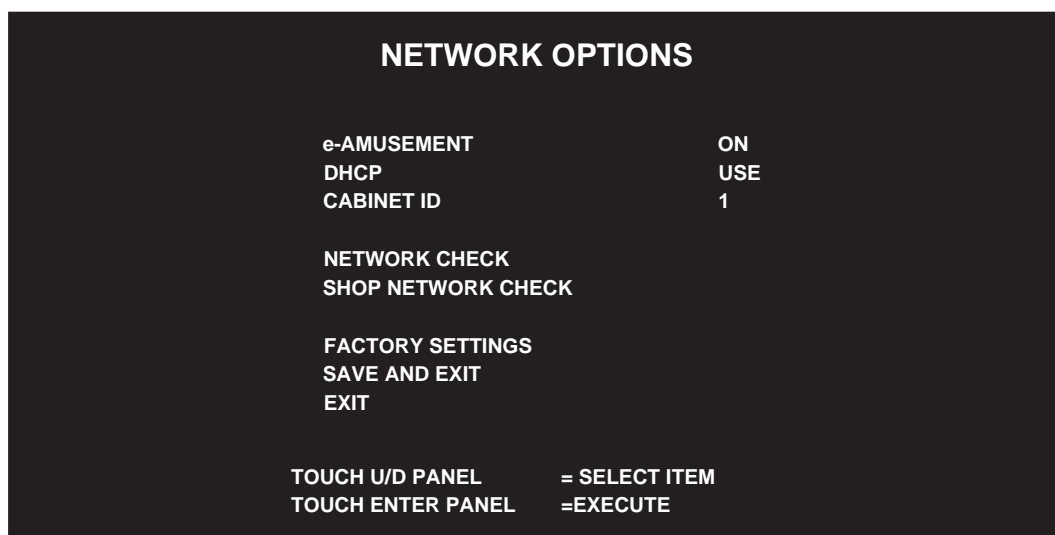

e-AMUSEMENT* (Factory setting: ON)	Select e-AMUSEMENT settings. ÿ ON: Uses the e-AMUSEMENT service. ÿ OFF: Do not use the e-AMUSEMENT service.
DHCP* (Factory setting: USE)	Set whether or not to use the DHCP function. ÿUSE: Use. ÿNOT USE: Not used. If "e-AMUSEMENT" is set to "ON", select "NOT USE". cannot be selected.
CABINET ID	Set the CABINET ID (1 to 16). If multiple units are installed, use different Please set the ID.
NETWORK CHECK	Checking the network communication status (ÿPage 76) (Cannot be selected if "e-AMUSEMENT" is set to "OFF")
SHOP NETWORK CHECK	Checking the in-store network communication status (ÿPage 78)
FACTORY SETTINGS	ENTER Touch the panel to enter all of the menu items. All settings will be restored to the factory settings.
SAVE AND EXIT	You can change the settings or restore the factory settings in "FACTORY SETTINGS". Even if you return to the previous state, the settings will not be reflected unless you confirm this item. plug.

* When you have changed the settings, after you select "SAVE AND EXIT", the message "NOW SAVING" will be displayed, followed by "PLEASE TURN OFF THE SWITCH AND REBOOT." So turn off the power, wait at least 10 seconds, and then restart the system.

(Continued)

(continuation)

Selecting an item	Touch the U or D panel.
Change settings	After selecting an item, touch the L or R panel.
Check screen display	"NETWORK CHECK" or "SHOP NETWORK Select "CHECK" and then touch the ENTER panel.
Back to MAIN MENU	Select "SAVE AND EXIT" or "EXIT" and then press the ENTER button. Touch the

NETWORK OPTIONS >> NETWORK CHECK

Checking the network status

ÿ Check the network communication status when using the e-AMUSEMENT function.

When the "e-AMUSEMENT" item is set to "ON" on the "NETWORK OPTIONS" item selection screen

It will only be displayed in.

After connecting to the network, be sure to check the communication status on this screen.



ÿ If the conditions for the check items are not met, a communication problem may be the cause.

Refer to "11 Troubleshooting" (ÿPage 183) for the solution.

If the same symptoms persist even after you have taken action, or if symptoms not listed in this manual occur immediately turn off the main power switch and unplug the power cord from the outlet.

Please contact the after-sales service center.

NETWORK CHECK

GAME ->- ROUTER ->- CENTER ->- SERVER

STATUS	CONNECTED
GAME TO ROUTER	15/15 (100%) 15/15
GAME TO CENTER	(100%) 15/15
GAME TO SERVER	(100%)
IP ADDRESS	10.3.5.10
SUBNET MASK	255.255.252.0
DEFAULT GATEWAY	10.3.4.1
DOMAIN NAME	eamuse.konami.fun
DNS SERVER	10.2.1.10
	-
DHCP SERVER	-
NTP SERVER	-
MAC ADDRESS	00:06:79:00:00:40

TOUCH EXIT PANEL = EXIT

<p>Communication status</p>	<p>The communication status to the e-AMUSEMENT center server is displayed. will be displayed.</p> <p>Display example ...GAME ->- ROUTER ->- CENTER ->- SERVER</p> <p>ÿ GAME: Main unit ÿ ROUTER: In-store VPN router ÿ CENTER: Entrance to e-AMUSEMENT ÿ SERVER: Center server</p> <p>If communication is normal, the ">" mark will appear. is moving from left to right at a nearly constant speed. Masu.</p> <p>If there is a communication error, the item that is not communicating will be displayed in red. It will be.</p> <div style="text-align: right;"> </div>
<p>STATUS</p>	<p>The communication status is displayed.</p> <p>ÿ CONNECTED: Communication is taking place. NOT CONNECTED: No communication is taking place.</p> <p>If it says "CONNECTED" then it's OK. It's normal.</p> <p>"-" is displayed while the communication status is being confirmed.</p> <div style="text-align: right;"> </div>

(Continued)

(continuation)

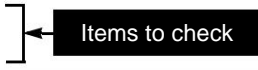
GAME TO ROUTER GAME TO CENTER GAME TO SERVER	The response from the main unit to each section is being checked. As shown in the figure, the numbers on the left and right are almost the same. This is normal. 
IP ADDRESS*	The IP address is displayed.
SUBNET MASK*	The subnet mask is displayed.
DEFAULT GATEWAY*	Displays the IP address of the default router.
DOMAIN NAME*	The domain name of the center server is displayed.
DNS SERVER*	Up to two DNS server IP addresses are displayed.
DHCP SERVER*	The IP address of the DHCP server is displayed.
NTP SERVER*	The IP address of the NTP server is displayed.
MAC ADDRESS*	The MAC address is displayed.

* It cannot be changed.

NETWORK OPTIONS

Return to item selection screen

EXIT Touch the panel

NETWORK OPTIONS >> SHOP NETWORK CHECK

Check the in-store network status

☺ Check the communication status with each unit.

SHOP NETWORK CHECK				
IP ADDRESS	VERSION	CABINET ID	STATUS	MATCHING
10.3.5.10	1	1	MYSELF	MYSELF
10.3.5.11	1	2	ALIVE	OK

TOUCH EXIT PANEL = EXIT

The diagram shows an example of two units installed.

IP ADDRESS*	The IP address of each unit is displayed.
VERSION	The online play version number is displayed.
CABINET ID	The "CABINET ID" set in "NETWORK OPTIONS" is displayed. (If you have multiple units, each unit will have a different Please enter "CABINET ID")
STATUS	The communication status between each unit is displayed. ☺ MYSELF: Your own body. ALIVE: Communication with other units is occurring. ☺ LOST: Communication is not possible. ☺ WAIT: Checking communication status.
MATCHING	It will show you whether matching is available in-store. ☺ MYSELF: Your own body. OK: -: Matching will be done in store. There is no matching in store. WAIT: Checking communication status.

* It cannot be changed.

NETWORK OPTIONS

Return to item selection screen

EXIT Touch the panel

MEMO ☺ The following conditions must be met to be matched in-store.

- The online play version numbers match
- The following settings in "GAME OPTIONS >> PLAY SETTINGS" match:
 - ☺ "MAX MEMBER (LOCAL)"

☺ The difference between the console started in normal game mode and the console started in event mode
No matching will occur.

BOOKKEEPING

• Displays aggregate data on the number of coins inserted.
View aggregated data about coins

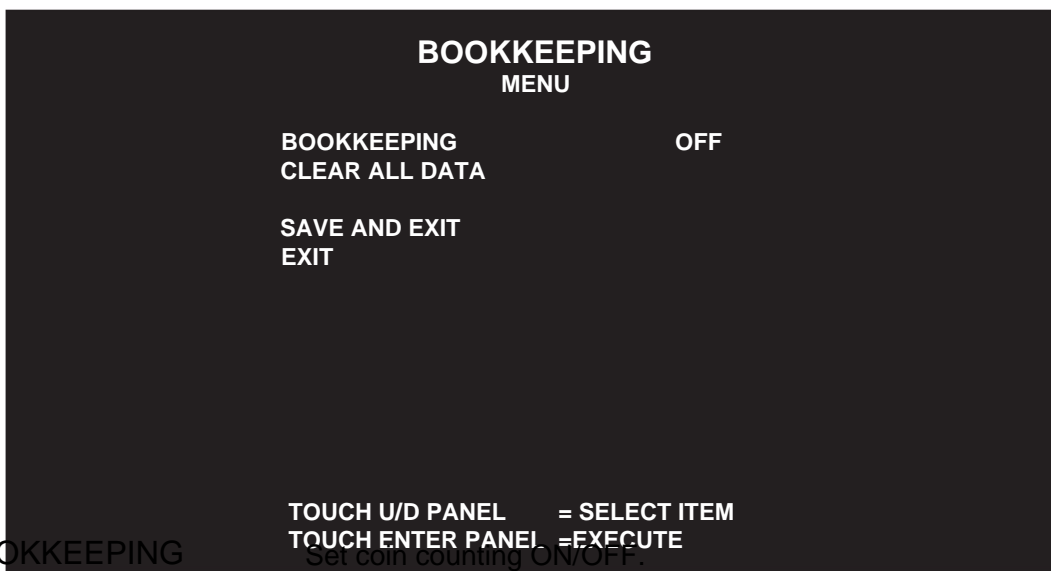

BOOKKEEPING

(Factory setting: OFF)

• ON: Coin counting is performed.

OFF: Coin counting is not performed. (The coin counting screen is not displayed.)
(Not available)

If you change the setting from ON to OFF, the aggregated data up to that point will be
It will be erased.

CLEAR ALL DATA Resets the coin count data to the factory settings.

ENTER Touch the panel to

SAVE AND EXIT

will be displayed, so touch the U or D panel to select.
Do you WANT TO CLEAR ALL DATA? YES/NO
If you select "YES", you will be asked to confirm again.
If you select "YES" again, "NOW ERASING" will be displayed.
The data will be erased immediately.
If you select "NO", "NOT CLEARED" will be displayed and the data will
No data will be erased.

Even if you set "BOOKKEEPING" to "ON/OFF",
If you do not confirm the items, the settings will not be reflected.

MEMO • If the time has not been set immediately after installation or initialization,

When you try to set "BOOKKEEPING" to "ON", the message "FIRST, SET THE
CLOCK. "CLOCK" ITEM IS IN MAIN MENU." appears, prompting you to set the time.
EXIT Touch the panel to cancel the display, then touch "CLOCK" to set the time.
Please set the time (•Page 85) .

Selecting an item

Touch the U or D panel.

Change settings

After selecting an item, touch the L or R panel.

Back to MAIN MENU
("BOOKKEEPING")

(Only when "OFF" is selected)

Select "SAVE AND EXIT" or "EXIT" and then touch the ENTER panel.

Display the coin count screen
("BOOKKEEPING")

(Only when set to "ON")

Select "SAVE AND EXIT" or "EXIT" and then touch the ENTER panel.

By setting the "BOOKKEEPING" item to "ON", the following coin tally screen will be displayed.

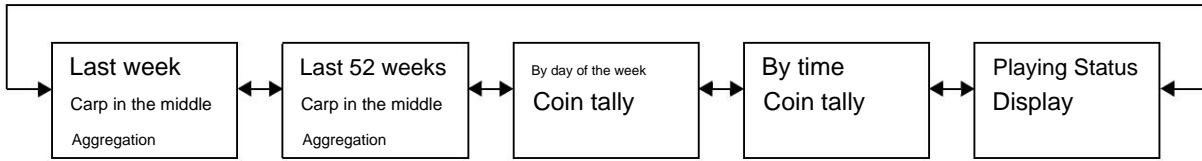

Next or previous summary screen
Show

Touch the L or R panel.

BOOKKEEPING's
Return to new screen

U Touch the panel

Return to MAIN MENU Touch the EXIT panel

Coin tally display for the past week

BOOKKEEPING	
COIN DATA OF LAST 7DAYS	
TODAY	100
LAST 7DAYS AVERAGE	135
LAST 7DAYS TOTAL	810
YESTERDAY	120
- 2 DAYS	130
- 3 DAYS	140
- 4 DAYS	110
- 5 DAYS	100
- 6 DAYS	210
- 7 DAYS	-
TOUCH L/R PANEL	= PREVIOUS/NEXT PAGE
TOUCH EXIT PANEL	= EXIT
TOUCH U PANEL	=SUBMENU

TODAY	Today's coins
LAST 7DAYS AVERAGE	Average number of coins over the last 7 days excluding today's number of coins
LAST 7DAYS TOTAL	Total coins for the last 7 days excluding today's coins
YESTERDAY	Yesterday's coins
-2 DAYS	Coins 2 days ago
-3 DAYS	Coins 3 days ago
-4 DAYS	Coins 4 days ago
-5 DAYS	Coins 5 days ago
-6 DAYS	Coins 6 days ago
-7 DAYS	Coins 7 days ago

Days without coin insertion will be displayed as "0".

Days for which data has not been collected are displayed as "-".

Coin tally display screen for the past 52 weeks (1 year)

BOOKKEEPING
COIN DATA OF LAST 52 WEEKS

-01 :	810	-14:	780	-27:	820	-40:	750
-02 :	-	-15:	-	-28:	-	-41:	-
-03 :	-	-16:	-	-29:	-	-42:	-
-04 :	-	-17:	-	-30:	-	-43:	-
-05 :	-	-18:	-	-31:	-	-44:	-
-06 :	-	-19:	-	-32:	-	-45:	-
-07 :	-	-20:	-	-33:	-	-46:	-
-08 :	-	-21:	-	-34:	-	-47:	-
-09 :	-	-22:	-	-35:	-	-48:	-
-10 :	-	-23:	-	-36:	-	-49:	-
-11 :	-	-24:	-	-37:	-	-50:	-
-12 :	-	-25:	-	-38:	-	-51:	-
-13 :	520	-26:	320	-39:	220	-52:	-

TOUCH L/R PANEL = PREVIOUS/NEXT PAGE
TOUCH EXIT PANEL = EXIT
TOUCH U PANEL =SUBMENU

-01:	Coins 1 week ago
-02:	Coins 2 weeks ago
• • •	• • •
-52:	Coins 52 weeks ago

Weeks with no coins inserted will be displayed as "0".
Weeks for which no data has been collected will be displayed as "-".

Coin tally display screen by day of the week

BOOKKEEPING
COIN DATA OF EACH DAY

	TOTAL
MONDAY	130
TUESDAY	140
WEDNESDAY	110
THURSDAY	100
FRIDAY	210
SATURDAY	-
SUNDAY	120

TOUCH L/R PANEL = PREVIOUS/NEXT PAGE
TOUCH EXIT PANEL = EXIT
TOUCH U PANEL =SUBMENU

MONDAY	Monday Coin Count
TUESDAY	Tuesday Coin Count
WEDNESDAY	Wednesday Coin Count
THURSDAY	Thursday Coin Count
FRIDAY	Friday Coin Count
SATURDAY	Saturday Coin Count
SUNDAY	Sunday Coin Count

Days of the week when no coins are inserted are displayed as "0".
Days of the week for which data is not collected are displayed as "-".

Coin tally display screen by time

BOOKKEEPING					
COIN DATA OF EACH HOUR					
	TOTAL		TOTAL		TOTAL
00 : 00	-	08:00	-	16:00	130
01: 00	-	09:00	-	17: 00	130
02: 00	-	10:00	-	18: 00	130
03: 00	-	11:00	88	19: 00	130
04: 00	-	12:00	12	20: 00	130
05: 00	-	13:00	12	21: 00	130
06:00	-	14:00	12	22:00	130
07:00	-	15:00	12	23:00	130

TOUCH L/R PANEL = PREVIOUS/NEXT PAGE
 TOUCH EXIT PANEL = EXIT
 TOUCH U PANEL =SUBMENU

00 : 00	Number of coins at 0:00
01:00	Number of coins in the 1 o'clock hour
02:00	Number of coins in the 2 o'clock hour
• • •	• • •
23:00	Coin count at 23:00

Any time without coin insertion will be displayed as "0".

Times for which data has not been collected are displayed as "-".

Play status display screen

BOOKKEEPING	
PLAY DATA SUMMARY	
TOTAL ACTIVE TIME	31H11M16S
TOTAL PLAY TIME	6H52M21S
AVERAGE PLAY TIME	25M04S
LONGEST PLAY TIME	30M14S
SHORTEST PLAY TIME	12M46S
TOTAL PLAY COUNT	55
2012-01-01(Sun) 12:17:12	
TOUCH L/R PANEL = PREVIOUS/NEXT PAGE TOUCH EXIT PANEL = EXIT TOUCH U PANEL =SUBMENU	

TOTAL ACTIVE TIME	Total operating time from the start of the calculation (31 hours, 11 minutes, 16 seconds shown)
TOTAL PLAY TIME	Total play time since the start of the count
AVERAGE PLAY TIME	Average playing time from start of counting
LONGEST PLAY TIME	Longest playing time since the start of counting
SHORTEST PLAY TIME	Shortest playing time from the start of counting
TOTAL PLAY COUNT	Total number of plays since the start of counting
2012-01-01 (Sun) 12:17:12	The current date and time displayed in "CLOCK" is in 24-hour format. (The figure shows the time of 12:17 on Sunday, January 1, 2012. <small>minutes 12 seconds</small>)

CLOCK

Setting the current

time ÿ Set the current

time. To count the coins inserted and the playing status, set the time in this mode. By setting the time, you can view the coin count and playing status in the closing setting and BOOKKEEPING.

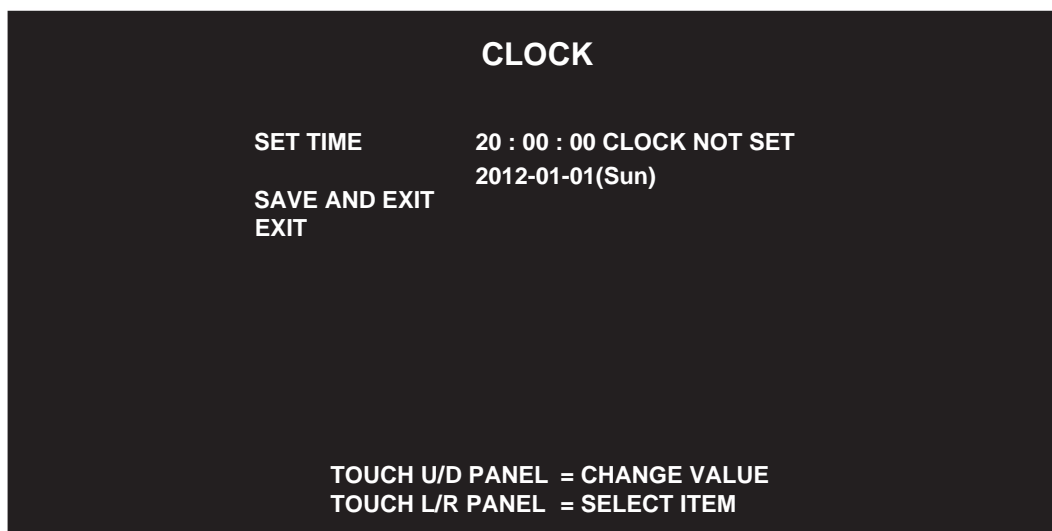

SET TIME	<p>The current time is displayed in 24-hour format. (If the current time has not been set, "CLOCK NOT SET" is displayed.) * The date cannot be set. When setting the time: After selecting SET TIME, touch the L or R panel to select the hour/minute/second. Touch the U or D panel to change the time.</p>
<p>Even if you set SAVE AND EXIT, it will not be reflected unless you confirm it in this item.</p>	

NOTE: If the time has not been set immediately after installing this product or after initializing it, the "FIRST, SET THE CLOCK. "CLOCK"" message will be displayed on the "BOOKKEEPING" menu screen and the "GAME SETTINGS" screen to prompt you to set the time. "ITEM IS IN MAIN MENU." is displayed.

Selecting an item

Touch the U or D panel.

Back to MAIN MENU

Select "SAVE AND EXIT" or "EXIT" and then touch the ENTER panel.

VIRTUAL COIN

Checking PASELI settings and aggregated data

ÿ Configure PASELI and check the aggregated data.

Virtual coin item selection screen

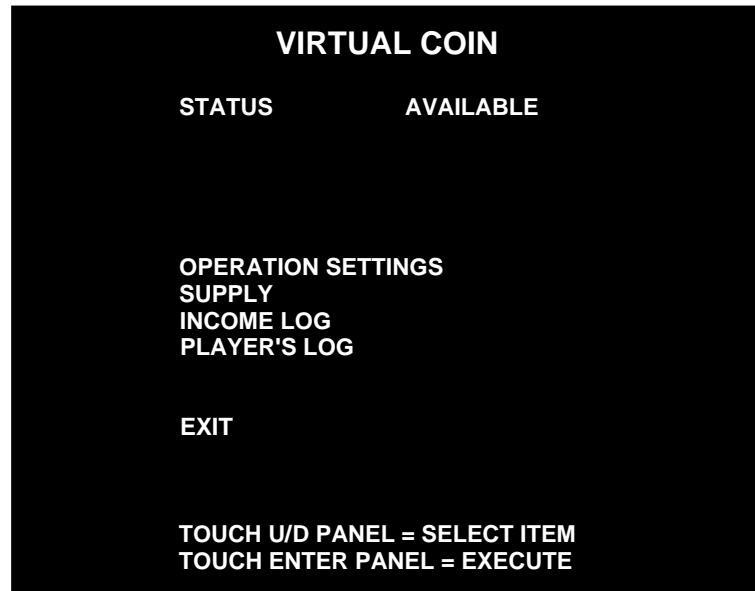

STATUS	Displays the setting status. AVAILABLE: NOT PASELI can be used. AVAILABLE: PASELI is not available.	
OPERATION SETTINGS	Set the play fee at PASELI (ÿPage 87)	
SUPPLY* (ÿPage 90)	Set the PASELI to serve the player. (equivalent to coin service button)	
INCOME LOG*	View aggregated data about PASELI usage I will.	(ÿPage 91)
PLAYER'S LOG*	To check the player's PASELI usage history screen will be displayed.	(ÿPage 97)

* If the STATUS is NOT AVAILABLE, it will be displayed in gray and cannot be selected.

Reasons for NOT AVAILABLE	Solution
FREE PLAY is set to ON in COIN OPTIONS. Is	Set FREE PLAY to OFF. (ÿPage 73)
e-AMUSEMENT is OFF in NETWORK OPTIONS is set to	Please set e-AMUSEMENT to ON. (ÿPage 74)
e-AMUSEMENT connection is currently unavailable due to network problems during maintenance. Not yet	Please wait a while until the maintenance is completed. See Network errors. (ÿPage 189)
PASELI service registration has not been completed	Please contact our sales representative.

Selecting an item

Touch the U or D panel.

Deciding on the item

After selecting an item, touch the ENTER panel.

Return to MAIN MENU Select "EXIT" and then touch ENTER panel

VIRTUAL COIN >> OPERATION SETTINGS

ÿ Set the price of playing at PASELI.

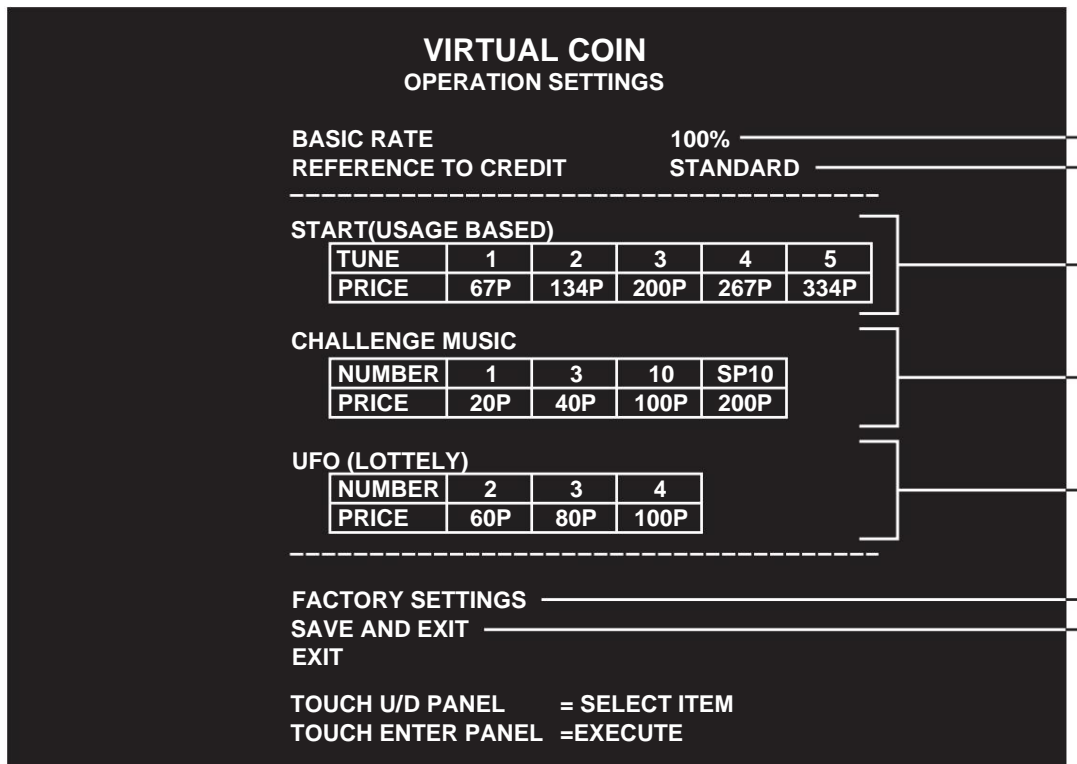

<p>BASIC RATE (Factory setting: 100%)</p>	<p>ÿ Set the percentage of the total playing fee at PASELI (30% to 120% in 1% increments).</p>												
<p>REFERENCE TO CREDIT (Factory setting: STANDARD)</p> <table border="1" data-bbox="159 1276 614 1467"> <tr> <td></td> <td>Page</td> <td>Q</td> </tr> <tr> <td></td> <td>P</td> <td>ÿ</td> </tr> <tr> <td></td> <td>↕</td> <td>↕</td> </tr> <tr> <td></td> <td>ÿÿ</td> <td>ÿ</td> </tr> </table>		Page	Q		P	ÿ		↕	↕		ÿÿ	ÿ	<p>ÿ Refer to the COIN SLOT setting and required credits set in COIN OPTIONS and the MAX TUNE (STANDARD) setting in GAME OPTIONS, and select the level to be reflected in the play fee for PASELI (ÿPage 88). The reflection levels are LIMITED, STANDARD, ALWAYS, EXPANDED and PLAY. There are four levels: EXPANDED and PLAY. As shown in the figure, the higher you go, the more freedom you have, but you need to be careful about the balance with the coin credit settings.</p>
	Page	Q											
	P	ÿ											
	↕	↕											
	ÿÿ	ÿ											
<p>START (USAGE BASED) ÿ The prices for</p>	<p>playing 1 to 5 songs are displayed. • The number of songs that can actually be played is determined by the MAX TUNE (USAGE BASED) setting under GAME OPTIONS >> PLAY SETTINGS (ÿpage 68). • Items that are displayed in grey cannot be played.</p>												
<p>CHALLENGE MUSIC ÿ Displays the fee for</p>	<p>the number of songs challenged.</p>												
<p>UFO (LOTTELY) ÿ The cost for the number of UFOs you can use to get the item is displayed. In the example shown, 80P is required to get 3 UFOs.</p>													
<p>FACTORY SETTINGS ÿ ENTER Touching</p>	<p>the panel will return all settings in this menu item to the factory defaults. ÿ Even if you change the settings or return</p>												
<p>SAVE AND EXIT</p>	<p>to the factory defaults in "FACTORY SETTINGS", the settings will not be reflected unless you confirm them in this item.</p>												

Selecting an item	Touch the U or D panel.
Change settings	After selecting an item, touch the L or R panel.
Deciding on the item	After selecting an item, touch the ENTER panel.
Return to Virtual Coin Selection Screen	Select "EXIT" or "SAVE AND EXIT" and then touch the ENTER panel.

MEMO ÿ The factory settings are designed to be well balanced with the COIN OPTIONS and GAME OPTIONS MAX TUNE (STANDARD) settings, so if you set them as you wish, the play fee for PASELI will be set at the same level without you having to set a specific play fee.

ÿ How to set your playing fees at PASELI

1 REFERENCE TO CREDIT ÿ, MAX TUNE of COIN OPTIONS and GAME OPTIONS

Select the level to be reflected in the playing fee on PASELI based on the (STANDARD) setting value. (See Table 1 and Table 2)

2. From BASIC RATE ÿ, set the overall ratio of the PASELI play fee. (See Table 2) 3. The

PASELI play fee calculated based on the settings will be displayed in the dotted frame. (Individual settings are not possible)

Table 1

LIMITED	The setting value of MAX TUNE (STANDARD) in COIN OPTIONS and GAME OPTIONS is not reflected. ÿ Playing fees at PASELI are determined according to BASIC RATE ÿ.
STANDARD	The maximum amount of play fees required is limited by referring to the MAX TUNE (STANDARD) settings of COIN OPTIONS and GAME OPTIONS. ÿ Even if you increase the BASIC RATE ÿ, the play fee will only increase up to the value determined by the MAX TUNE (STANDARD) settings of COIN OPTIONS and GAME OPTIONS.
ALWAYS	The play fee always reflects the settings of COIN OPTIONS and MAX TUNE (STANDARD) of GAME OPTIONS.
EXPANDED	All play fees are automatically set based on the COIN OPTIONS settings.

MEMO ÿ The play fees shown in yellow are COIN OPTIONS and GAME OPTIONS. It is calculated from the MAX TUNE (STANDARD) setting. If you want to change it, change the MAX TUNE (STANDARD) setting in COIN OPTIONS and GAME OPTIONS, or change it in REFERENCE TO CREDIT ÿ.

Table 2

PASELI Rates	REFERENCE TO CREDIT ÿ			
	LIMITED	STANDARD	ALWAYS	EXPANDED
•START (USAGE BASED)ÿ •CHALLENGE MUSIC ÿ	Factory setting x BASIC RATE ÿ	Factory setting x BASIC RATE ÿ (COIN OPTIONS GAME OPTIONS MAX TUNE (The setting value of STANDARD will not be higher than the reference value))	COIN OPTIONS GAME OPTIONS MAX TUNE Reflect the value referred to (STANDARD)	COIN OPTIONS GAME OPTIONS MAX TUNE Reflect the value referred to (STANDARD)
•UFO (LOTTELY)ÿ	Factory setting x BASIC RATE ÿ	Factory setting x BASIC RATE ÿ	Factory setting x BASIC RATE ÿ	COIN OPTIONS GAME OPTIONS MAX TUNE Automatically calculate using the value referenced in (STANDARD)

Example of play fee

This is an example of play fee settings in OPERATION SETTINGS when MAX TUNE (STANDARD) of COIN OPTIONS and GAME OPTIONS is the factory setting.

BASIC RATE: 110%	BASIC RATE: 90%																																																												
REFERENCE TO CREDIT: LIMITED START (USAGE BASED) <table border="1"> <tr><td>TUNE</td><td>1</td><td>2</td><td>3</td><td>4</td><td>5</td></tr> <tr><td>PRICE</td><td>74P</td><td>147P</td><td>220P</td><td>294P</td><td>367P</td></tr> </table> CHALLENGE MUSIC <table border="1"> <tr><td>NUMBER</td><td>1</td><td>3</td><td>10</td><td>SP10</td></tr> <tr><td>PRICE</td><td>22P</td><td>44P</td><td>110P</td><td>220P</td></tr> </table> UFO (LOTTELY) <table border="1"> <tr><td>NUMBER</td><td>2</td><td>3</td><td>4</td></tr> <tr><td>PRICE</td><td>66P</td><td>88P</td><td>110P</td></tr> </table>	TUNE	1	2	3	4	5	PRICE	74P	147P	220P	294P	367P	NUMBER	1	3	10	SP10	PRICE	22P	44P	110P	220P	NUMBER	2	3	4	PRICE	66P	88P	110P	REFERENCE TO CREDIT: LIMITED START (USAGE BASED) <table border="1"> <tr><td>TUNE</td><td>1</td><td>2</td><td>3</td><td>4</td><td>5</td></tr> <tr><td>PRICE</td><td>60P</td><td>120P</td><td>180P</td><td>240P</td><td>300P</td></tr> </table> CHALLENGE MUSIC <table border="1"> <tr><td>NUMBER</td><td>1</td><td>3</td><td>10</td><td>SP10</td></tr> <tr><td>PRICE</td><td>18P</td><td>36P</td><td>90P</td><td>180P</td></tr> </table> UFO (LOTTELY) <table border="1"> <tr><td>NUMBER</td><td>2</td><td>3</td><td>4</td></tr> <tr><td>PRICE</td><td>54P</td><td>72P</td><td>90P</td></tr> </table>	TUNE	1	2	3	4	5	PRICE	60P	120P	180P	240P	300P	NUMBER	1	3	10	SP10	PRICE	18P	36P	90P	180P	NUMBER	2	3	4	PRICE	54P	72P	90P
TUNE	1	2	3	4	5																																																								
PRICE	74P	147P	220P	294P	367P																																																								
NUMBER	1	3	10	SP10																																																									
PRICE	22P	44P	110P	220P																																																									
NUMBER	2	3	4																																																										
PRICE	66P	88P	110P																																																										
TUNE	1	2	3	4	5																																																								
PRICE	60P	120P	180P	240P	300P																																																								
NUMBER	1	3	10	SP10																																																									
PRICE	18P	36P	90P	180P																																																									
NUMBER	2	3	4																																																										
PRICE	54P	72P	90P																																																										
REFERENCE TO CREDIT: STANDARD START (USAGE BASED) <table border="1"> <tr><td>TUNE</td><td>1</td><td>2</td><td>3</td><td>4</td><td>5</td></tr> <tr><td>PRICE</td><td>67P</td><td>134P</td><td>200P</td><td>267P</td><td>334P</td></tr> </table> CHALLENGE MUSIC <table border="1"> <tr><td>NUMBER</td><td>1</td><td>3</td><td>10</td><td>SP10</td></tr> <tr><td>PRICE</td><td>20P</td><td>40P</td><td>100P</td><td>200P</td></tr> </table> UFO (LOTTELY) <table border="1"> <tr><td>NUMBER</td><td>2</td><td>3</td><td>4</td></tr> <tr><td>PRICE</td><td>60P</td><td>80P</td><td>100P</td></tr> </table>	TUNE	1	2	3	4	5	PRICE	67P	134P	200P	267P	334P	NUMBER	1	3	10	SP10	PRICE	20P	40P	100P	200P	NUMBER	2	3	4	PRICE	60P	80P	100P	REFERENCE TO CREDIT: STANDARD START (USAGE BASED) <table border="1"> <tr><td>TUNE</td><td>1</td><td>2</td><td>3</td><td>4</td><td>5</td></tr> <tr><td>PRICE</td><td>60P</td><td>120P</td><td>180P</td><td>240P</td><td>300P</td></tr> </table> CHALLENGE MUSIC <table border="1"> <tr><td>NUMBER</td><td>1</td><td>3</td><td>10</td><td>SP10</td></tr> <tr><td>PRICE</td><td>18P</td><td>36P</td><td>90P</td><td>180P</td></tr> </table> UFO (LOTTELY) <table border="1"> <tr><td>NUMBER</td><td>2</td><td>3</td><td>4</td></tr> <tr><td>PRICE</td><td>54P</td><td>72P</td><td>90P</td></tr> </table>	TUNE	1	2	3	4	5	PRICE	60P	120P	180P	240P	300P	NUMBER	1	3	10	SP10	PRICE	18P	36P	90P	180P	NUMBER	2	3	4	PRICE	54P	72P	90P
TUNE	1	2	3	4	5																																																								
PRICE	67P	134P	200P	267P	334P																																																								
NUMBER	1	3	10	SP10																																																									
PRICE	20P	40P	100P	200P																																																									
NUMBER	2	3	4																																																										
PRICE	60P	80P	100P																																																										
TUNE	1	2	3	4	5																																																								
PRICE	60P	120P	180P	240P	300P																																																								
NUMBER	1	3	10	SP10																																																									
PRICE	18P	36P	90P	180P																																																									
NUMBER	2	3	4																																																										
PRICE	54P	72P	90P																																																										
REFERENCE TO CREDIT: ALWAYS/EXPANDED START (USAGE BASED) <table border="1"> <tr><td>TUNE</td><td>1</td><td>2</td><td>3</td><td>4</td><td>5</td></tr> <tr><td>PRICE</td><td>67P</td><td>134P</td><td>200P</td><td>267P</td><td>334P</td></tr> </table> CHALLENGE MUSIC <table border="1"> <tr><td>NUMBER</td><td>1</td><td>3</td><td>10</td><td>SP10</td></tr> <tr><td>PRICE</td><td>20P</td><td>40P</td><td>100P</td><td>200P</td></tr> </table> UFO (LOTTELY) <table border="1"> <tr><td>NUMBER</td><td>2</td><td>3</td><td>4</td></tr> <tr><td>PRICE</td><td>60P</td><td>80P</td><td>100P</td></tr> </table>	TUNE	1	2	3	4	5	PRICE	67P	134P	200P	267P	334P	NUMBER	1	3	10	SP10	PRICE	20P	40P	100P	200P	NUMBER	2	3	4	PRICE	60P	80P	100P	REFERENCE TO CREDIT: ALWAYS/EXPANDED START (USAGE BASED) <table border="1"> <tr><td>TUNE</td><td>1</td><td>2</td><td>3</td><td>4</td><td>5</td></tr> <tr><td>PRICE</td><td>67P</td><td>134P</td><td>200P</td><td>267P</td><td>334P</td></tr> </table> CHALLENGE MUSIC <table border="1"> <tr><td>NUMBER</td><td>1</td><td>3</td><td>10</td><td>SP10</td></tr> <tr><td>PRICE</td><td>20P</td><td>40P</td><td>100P</td><td>200P</td></tr> </table> UFO (LOTTELY) <table border="1"> <tr><td>NUMBER</td><td>2</td><td>3</td><td>4</td></tr> <tr><td>PRICE</td><td>60P</td><td>80P</td><td>100P</td></tr> </table>	TUNE	1	2	3	4	5	PRICE	67P	134P	200P	267P	334P	NUMBER	1	3	10	SP10	PRICE	20P	40P	100P	200P	NUMBER	2	3	4	PRICE	60P	80P	100P
TUNE	1	2	3	4	5																																																								
PRICE	67P	134P	200P	267P	334P																																																								
NUMBER	1	3	10	SP10																																																									
PRICE	20P	40P	100P	200P																																																									
NUMBER	2	3	4																																																										
PRICE	60P	80P	100P																																																										
TUNE	1	2	3	4	5																																																								
PRICE	67P	134P	200P	267P	334P																																																								
NUMBER	1	3	10	SP10																																																									
PRICE	20P	40P	100P	200P																																																									
NUMBER	2	3	4																																																										
PRICE	60P	80P	100P																																																										

The numbers in the grey boxes are the MAX TUNE (STANDARD) settings for COIN OPTIONS and GAME OPTIONS.

The value cannot be changed within OPERATION SETTINGS as it is calculated based on the setting value.

*1 The upper limit is limited by the settings of MAX TUNE (STANDARD) in COIN OPTIONS and GAME OPTIONS.

Therefore, the calculation is different from that of BASIC RATE ÷.

*2 This only refers to the MAX TUNE (STANDARD) of COIN OPTIONS and GAME OPTIONS, so the value will not change even if you change BASIC RATE ÷.

MEMO ÷ If you perform ALL FACTORY SETTINGS, the settings will be restored to the factory settings.

Be sure to check your settings.

Based on MAX TUNE (STANDARD) of COIN OPTIONS and GAME OPTIONS

Items that are calculated based on the settings may be changed even if the item is operated with the factory settings.

COIN OPTIONS or GAME OPTIONS MAX TUNE (STANDARD)

The numbers may change if you change them in

÷ Playing fees at PASELI range from 10P to 1000P.

- If the setting condition calculation results in a value below 10P, the lower limit of 10P will be set.

- If the calculation of the setting conditions results in a value greater than 1000P, the upper limit of 1000P will be set.

VIRTUAL COIN >> SUPPLY

ÿ Set the PASELI to serve to the player (equivalent to the coin service button).

If the power goes out during play, we can provide you with PASELI that can be used with this game machine. PASELI cannot be refunded to players.



EXTRA PASELI	Set the amount of PASELI to be served to the player. *See below for how to set it. Reset the set amount
CLEAR	to 0. Set the set amount and
SET AND EXIT	exit the item. Exit the item without setting it.
EXIT	

Selecting an item

Touch the U or D panel.

Deciding on the item

After selecting an item, touch the ENTER panel.

Return to Virtual Coin Selection Screen

Select "SET AND EXIT" or "EXIT" and then touch the ENTER panel.

"EXTRA PASELI" setting method

- 1 Select EXTRA PASELI, touch the L or R panel to select the number of digits, and then touch the U or D panel Touch to enter a number. (There is an upper limit to the number.)
- 2 Select and confirm SET AND EXIT, and "SET EXTRA PASELI ****P" will be displayed. You will return to the coin selection screen.

MEMO ÿ The set EXTRA PASELI will be displayed at the bottom of the sub monitor screen in game mode.

ÿ To reset the EXTRA PASELI you have set, enter the test mode again. The EXTRA PASELI will be reset to 0, as will the COIN CREDIT. ÿ The EXTRA PASELI will not be saved, so when you restart the game, the EXTRA PASELI will be reset. PASELI will return to 0.

VIRTUAL COIN >> INCOME LOG

ÿ View aggregated data about PASELI used.

Please enter your password to display the summary data screen.

Password authentication screen

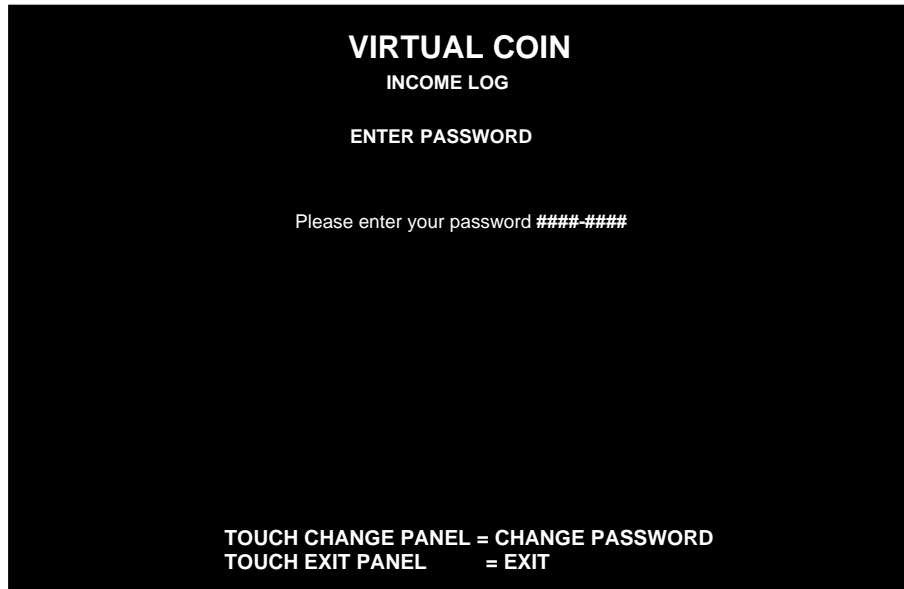

Display the summary data screen (number panel)	Touch the number panel to enter the password (8 digits). • Display when no password is entered: # • Display
change password (CHANGE panel)	when password is entered: * Touch the CHANGE panel to display the password change screen (ÿPage 92) .

MEMO ÿ You can clear the password you are entering by touching the correction panel.
Masu.

Important: The initial password is "0000-0000".

ÿ To prevent the leakage of sales information, be sure to change the initial password and Don't let the words slip out.

ÿ The password is stored on the server, and the changed password can be used not only on this product but on all PASELI-compatible gaming machines in the store.

If an error message appears, enter your password again correctly.

Error display	Solution
Incorrect password	Please enter the correct password. Check the
Could not get PASELI information	connection of the network device and enter the password again.

Return to Virtual Coin Selection Screen

EXIT Touch the panel

Password change screen

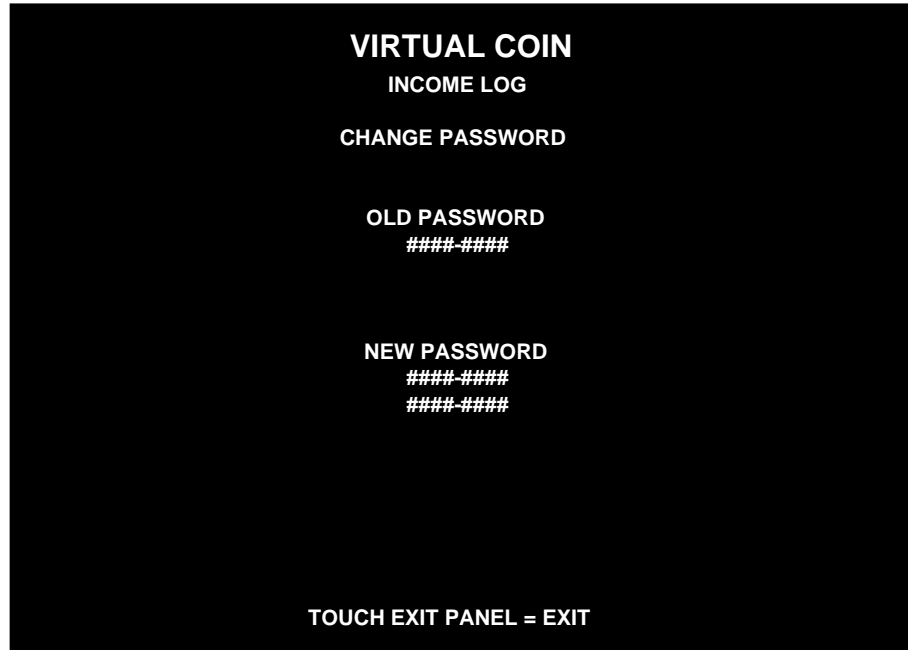

OLD PASSWORD	Touch the number panel and enter your old password (8 digits). • Display when no password is entered: # • Display when password is
NEW PASSWORD	entered: * Touch the number panel and enter your new password (8 digits) twice. • Display when no password is entered: # • Display when password is entered: *

MEMO • You can clear the password you are entering by touching the correction panel.
Masu.

Error message	Cause	Solution:
Confirm password is not correct are incorrect. Do not change password. Enter your old password.	The first and second passwords are incorrect. Enter your	Enter the same password for NEW PASSWORD both times.
is incorrect. OLD PASSWORD is incorrect.	The password you entered	Please enter a NEW PASSWORD that is different from the OLD PASSWORD.
Your password change may have failed.	Network Error	Please enter the old password correctly in OLD PASSWORD. 1 Check the connection of the network device. 2 Next, enter INCOME LOG again and enter the old password. (If this fails, enter the new password.) 3 Change the password again.

Return to Virtual Coin Selection Screen

EXIT Touch the panel

Each time you press the TEST button or SELECT button, the screen will change as follows:

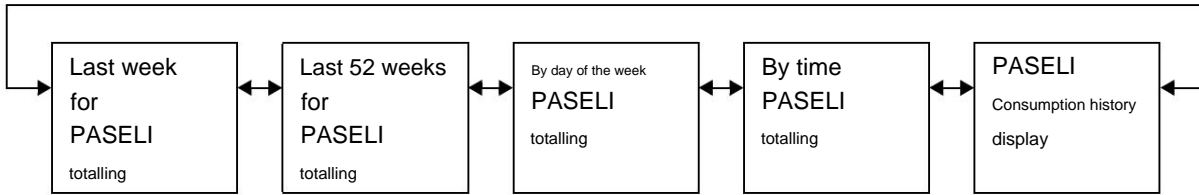

PASELI summary display screen for the past week

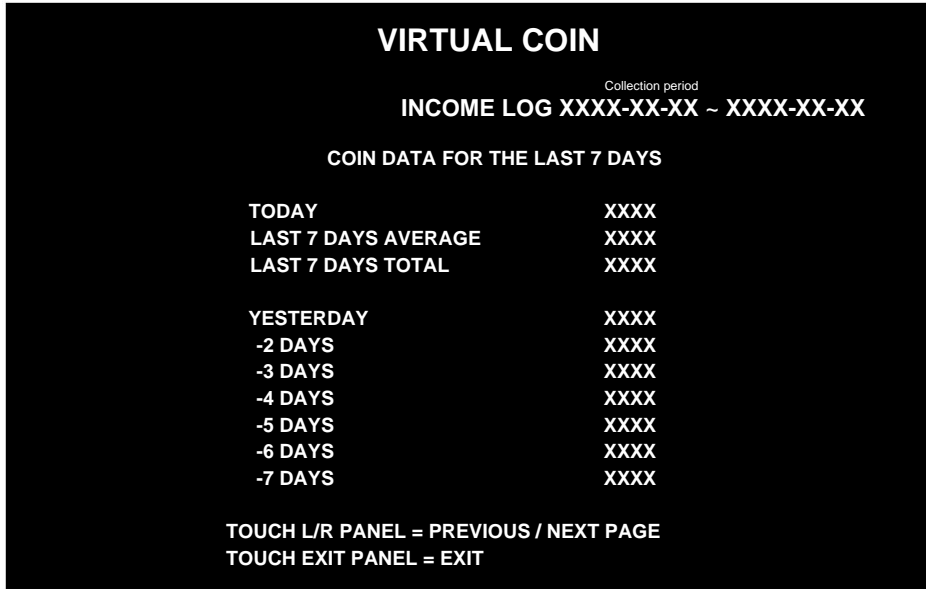

Collection period	Server-side aggregation period If not tallied, "Not tallied" will be displayed.
TODAY	Today's PASELI spending
LAST 7 DAYS AVERAGE	Average PASELI consumption for the past week excluding today
LAST 7 DAYS TOTAL	Total PASELI consumption for the past week excluding today
YESTERDAY	Yesterday's PASELI consumption
-2 DAYS	PASELI spent 2 days ago
-3 DAYS	PASELI spent 3 days ago
-4 DAYS	PASELI spent 4 days ago
-5 DAYS	PASELI spent 5 days ago
-6 DAYS	PASELI spent 6 days ago
-7 DAYS	PASELI spending 7 days ago

Display the previous summary screen. Touch the L panel.

Display the next summary screen R Touch the panel

Virtual Coin Items
Return to selection screen

EXIT Touch the panel

MEMO If information cannot be obtained during aggregation, the following message will be displayed.

We are currently unable to obtain information as it is being collected.
Please try again later

PASELI summary display screen for the past 52 weeks (1 year)

VIRTUAL COIN	
Collection period	
INCOME LOG XXXX-XX-XX ~ XXXX-XX-XX	
COIN DATA OF LAST 52 WEEKS	
-01	: XXXX -14 : XXXX -27 : XXXX -40 : XXXX
-02	: XXXX -15 : XXXX -28 : XXXX -41 : XXXX
-03	: XXXX -16 : XXXX -29 : XXXX -42 : XXXX
	: : :
-11	: XXXX -24 : XXXX -37 : XXXX -50 : XXXX
-12	: XXXX -25 : XXXX -38 : XXXX -51 : XXXX
-13	: XXXX -26 : XXXX -39 : XXXX -52 : XXXX
TOUCH L/R PANEL = PREVIOUS / NEXT PAGE	
TOUCH EXIT PANEL = EXIT	

Aggregation	Server-side aggregated time duration
period -01:	PASELI spending from last week
-02:	PASELI spending 2 weeks ago
• • •	• • •
-52:	PASELI Spending 52 Weeks Ago

PASELI summary display screen by day of the week

VIRTUAL COIN	
Collection period	
INCOME LOG XXXX-XX-XX ~ XXXX-XX-XX	
COIN DATA OF EACH DAY	
	TOTAL
MONDAY	XXXX
TUESDAY	XXXX
WEDNESDAY	XXXX
THURSDAY	XXXX
FRIDAY	XXXX
SATURDAY	XXXX
SUNDAY	XXXX
TOUCH L/R PANEL = PREVIOUS / NEXT PAGE	
TOUCH EXIT PANEL = EXIT	

Collection period	Server-side aggregation period
MONDAY	Monday's PASELI spending
TUESDAY	PASELI Spent on Tuesday
WEDNESDAY	PASELI spending on Wednesday
THURSDAY	Thursday's PASELI spending
FRIDAY	Friday PASELI spending
SATURDAY	Saturday PASELI spending
SUNDAY	Sunday PASELI spending

This is a cumulative total for each collection period, so the calculation method is different from BOOKKEEPING.

PASELI summary display screen by hour

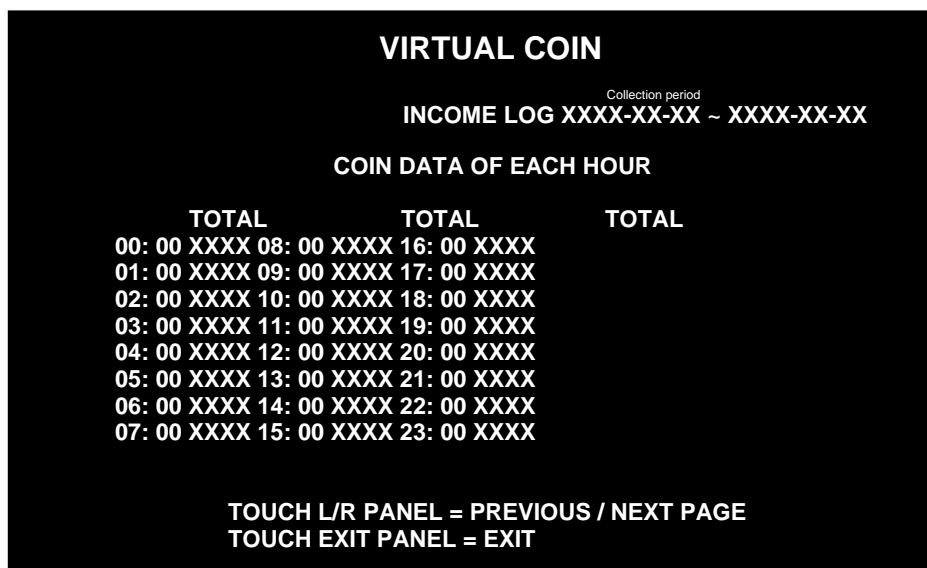

Aggregation	Period aggregated on the server side
period	PASELI consumption amount at 0:00
00:00	PASELI consumption amount at 1:00
01:00 02:00	PASELI consumption amount at 2:00
•	•
•	•
•	•
23:00	This is a cumulative total for each PASELI consumption

collection period in the 23:00 hour period, so the calculation method is different from that of BOOKKEEPING.

PASELI consumption history display screen for the last 20 items

VIRTUAL COIN

Aggregation date and time
INCOME LOG XXXX-XX-XX XX:XX:XX

DETAIL

DATE	TIME	CONSUME	SUPPLY	-1 XXXX.XX.XX	CARD
13:40:00	0	-2	XXXX.XX.XX	13:38:34 0 -3	XXXX.XX.XX
13:37:07	0	-4	XXXX.XX.XX	13:35:41 66 -5	XXXX.XX.XX
13:34:14	0	-6	XXXX.XX.XX	13:32:48 0 -7	XXXX.XX.XX
13:31:22	0	-8	XXXX.XX.XX	13:29:55 0 -9	XXXX.XX.XX
13:28:29	0	-10	XXXX.XX.XX	13:27:02 0 -10	XXXX.XX.XX
13:25:36	0	-12	XXXX.XX.XX	13:24:10 0 -13	XXXX.XX.XX
13:22:43	0	-14	XXXX.XX.XX	13:21:17 0 -15	XXXX.XX.XX
13:19:50	0	-16	XXXX.XX.XX	13:18:24 66 -17	XXXX.XX.XX
13:16:58	0	-18	XXXX.XX.XX	13:15:31 0 -19	XXXX.XX.XX
13:14:05	0	-20	XXXX.XX.XX	13:12: 38 0	XX
					XX
					XX
					XX
					XX
					XX
					XX
					0
					XX
					XX
					XX
					XX
					XX

TOUCH L/R PANEL = PREVIOUS / NEXT PAGE
TOUCH EXIT PANEL = EXIT

<small>Aggregation date and time</small>	Date and time collected on the server side
DATE	Date PASELI was consumed
TIME	Time spent using PASELI
CONSUME	Normal consumption amount used
SUPPLY	Invested in VIRTUAL COIN SUPPLY Amount using EXTRA PASELI
CARD	e-AMUSEMENT PASS card number (User code) first 4 digits

VIRTUAL COIN >> PLAYER'S LOG

ÿ Displays a screen for checking the player's PASELI usage history. This is used by the player to check whether PASELI has been consumed if the power goes out during play due to a power outage or other reason. Please have the e-AMUSEMENT PASS you wish to check ready. e-AMUSEMENT PASS standby screen

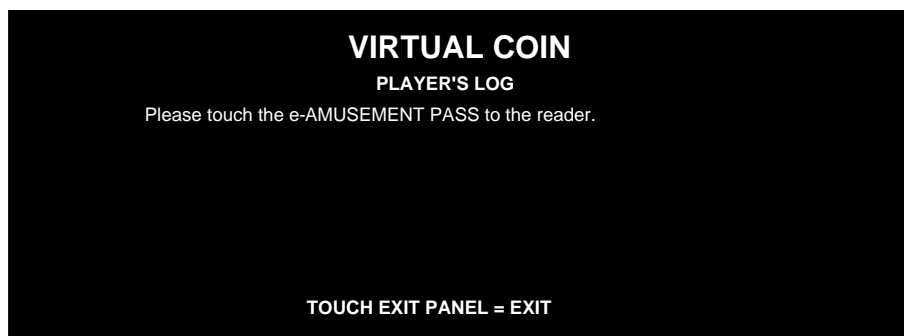

PIN entry screen

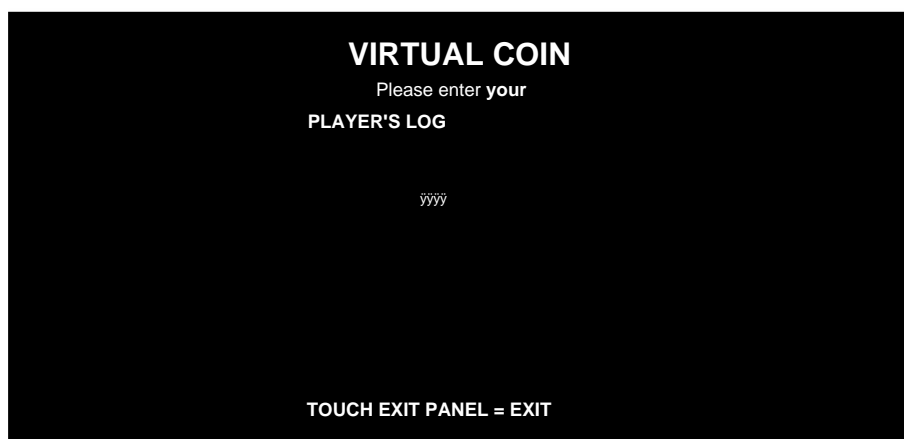

ÿ How to check 1

Place the e-AMUSEMENT PASS over the reader. **2**

Touch the number panel to enter the 4-digit PIN for your e-AMUSEMENT PASS. **3** A confirmation screen will appear, allowing you to check your current PASELI usage history and remaining balance.

•If the error "PASELI cannot be used" is displayed, it is possible that an e-AMUSEMENT PASS for which PASELI is not valid has been used, so please inform the player that PASELI is not being used with this e-AMUSEMENT PASS. •If any other error is displayed, please take the following measures.

Error	Solution: Use
message: This card cannot be used.	an e-AMUSEMENT PASS that is compatible with this product. Enter the correct
The PIN is incorrect	PIN code. Check the connection of the network
Unable to obtain PASELI information Unable to obtain PASELI information at this time Please try again later	device. (ÿPage 142) Wait a while and check again.
PASELI is not available. The server is currently under maintenance.	Please check again after a while.

MEMO ÿ You can clear the password you are entering by touching the correction panel. Masu.

Confirmation screen

VIRTUAL COIN

Aggregation date and time
PLAYER'S LOG XXXX-XX-XX XX:XX:XX
Balance 1234 P

DATE	TIME	CONSUME	SUPPLY	-1	XXXX.XX.XX	CARD
13:40:00	0 -2	XXXX.XX.XX	13:38:34	0 -3	XXXX.XX.XX	XXXX...
13:37:07	0 -4	XXXX.XX.XX	13:35:41	66 -5	XXXX.XX.XX	XXXX...
13:34:14	0 -6	XXXX.XX.XX	13:32:48	0 -7	XXXX.XX.XX	XXXX...
13:31:22	0 -8	XXXX.XX.XX	13:29:55	0 -9	XXXX.XX.XX	XXXX...
13:28:29	0 -10	XXXX.XX.XX	13:27:02	0 -11	XXXX.XX.XX	XXXX...
13:25:36	0 -12	XXXX.XX.XX	13:24:10	0 -13	XXXX.XX.XX	XXXX...
13:22:43	0 -14	XXXX.XX.XX	13:21:17	0 -15	XXXX.XX.XX	XXXX...
13:19:50	0 -16	XXXX.XX.XX	13:18:24	66 -17	XXXX.XX.XX	XXXX...
13:16:58	0 -18	XXXX.XX.XX	13:15:31	0 -19	XXXX.XX.XX	XXXX...
13:14:05	0 -20	XXXX.XX.XX	13:12:38	0	XX	XXXX...
					XX	XXXX...
					XX	XXXX...
					XX	XXXX...
					XX	XXXX...
					XX	XXXX...
					XX	XXXX...
					0	XXXX...
					XX	XXXX...
					XX	XXXX...
					XX	XXXX...
					XX	XXXX...

TOUCH EXIT PANEL = EXIT

Aggregation date and	Date and time collected on the server side
time Balance	View your current PASELI balance.
DATE*	Date PASELI was consumed
TIME*	Time spent using PASELI
CONSUME*	Normal consumption amount used
SUPPLY*	Invested in VIRTUAL COIN SUPPLY Amount using EXTRA PASELI
CARD*	e-AMUSEMENT PASS card number (User code) first 4 digits

* Displays the usage history of PASELI on this console.

Virtual Coin Items
 Return to selection screen

EXIT Touch the panel

ALL FACTORY SETTINGS

Reset to factory settings ý

Reset some of the test mode settings to the factory settings.

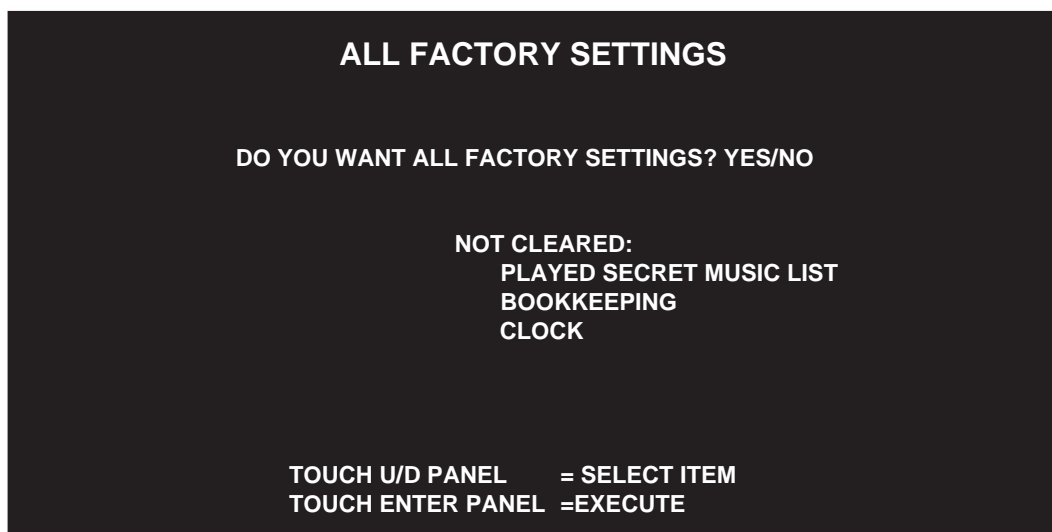

DO YOU WANT ALL FACTORY SETTINGS?	The settings made in test mode will be reset to the factory settings.
-----------------------------------	---

ý To restore the factory settings: Select "YES" ý To not

restore the factory settings: Select "NO" ý "NO MODIFICATION" is displayed and the factory settings are restored.

The screen will return to the MAIN MENU screen without changing the setting.

If you select "YES", you will be asked to confirm again.

SURE? YES/NO

ý To restore the factory settings: Select "YES" ý "NOW SAVING" is displayed and the settings are restored to the factory settings.

(The message "PLEASE TURN OFF THE SWITCH AND REBOOT." may be displayed.

In this case, turn off the power, wait 10 seconds or more, and then restart the unit.) Do

not restore to factory settings: Select "NO" ý "NO MODIFICATION" will be displayed and the screen will return to the MAIN MENU screen without restoring to the factory settings.

NOT CLEARED	Displays the items that cannot be restored to the factory settings.
-------------	---

Selecting an item

Touch the U or D panel.

Deciding on the item

After selecting an item, touch the ENTER panel.

MEMO ý The following menu items will be reset to their factory settings.

- ý "SOUND OPTIONS"
- ý "GAME OPTIONS"
- ý "COIN OPTIONS"
- ý "NETWORK OPTIONS"
- ý "VIRTUAL COIN" "OPERATION SETTINGS"

ý The following menu items will not be in the factory settings.

- ý "PLAYED SECRET MUSIC LIST" in "GAME OPTIONS"
- ý "BOOKKEEPING"
- ý "CLOCK"

ý To completely restore the unit to its factory

settings: **1.** Turn off the sub power

switch. **2.** While pressing the TEST button, turn on the sub power switch.

3. After checking that the following screen is displayed, release the TEST button and restart the unit.
Sai.

**INITIALIZING THE BACKUP RAM COMPLETE.
PLEASE TURN OFF THE SWITCH AND REBOOT.**

4 After initialization, register the store name in "SHOP SETTINGS" in "GAME OPTIONS".

Be sure to register your shop name (SHOP NAME SETTINGS) and area (SHOP AREA) (ýPage 69).

SYSTEM INFORMATION

Viewing information about the system

ÿ View information about the system.

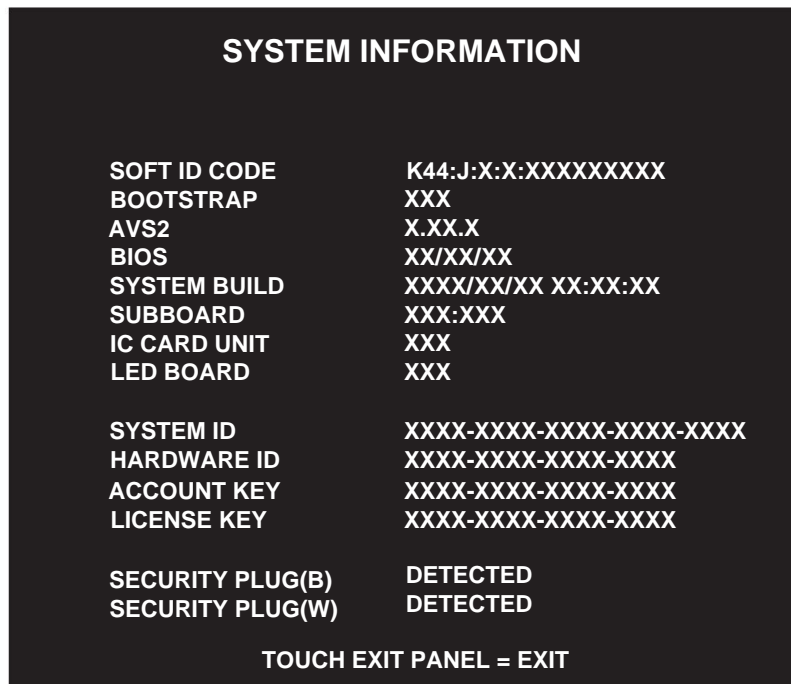

SOFT ID CODE	Displays the version of the game software.
BOOTSTRAP	Displays the version of the boot software.
AVS2	Displays the version of the system library.
BIOS	Displays the BIOS date of the PCB unit.
SYSTEM BUILD	Displays the system build date and time.
SUBBOARD	Displays the sub-board version.
IC CARD UNIT	Check the firmware version of the IC card reader I/O board. It is displayed.
LED BOARD	Displays the firmware version of the LED control board.
SYSTEM ID	Shows the system ID.
HARDWARE ID	Displays the hardware ID.
ACCOUNT KEY	Displays the account key information.
LICENSE KEY	Displays the license key information.
SECURITY PLUG(B) *	Indicates whether the security plug is installed at start-up. Shows:
SECURITY PLUG(W) *	Check that the e-AMUSEMENT plug is installed at startup. Display.

* If the plug is not installed, this item will not be displayed.

(The diagram is an example for explanation purposes.)

Return to MAIN MENU Touch the EXIT panel

EVENT MODE Start

operation in event mode. This mode is set for events such as in-store tournaments run by customers. This can be selected when "FREE PLAY" is set to "ON" in "COIN OPTIONS".

How to set up

Select "EVENT MODE" on the MAIN MENU screen. You will be returned to the game screen when the event mode is set. (This cannot be selected if "FREE PLAY" in "COIN OPTIONS" is set to "OFF")

How to return to normal mode

Select "GAME MODE" on the MAIN MENU screen of the test mode

MEMO • When "EVENT MODE" is set, the following points will be different from normal game mode. - "EVENT MODE" will be displayed at the bottom of the sub monitor screen. - There will be no game over. - There will be no timeout on the selection screen and result display when playing. - Matching will not be possible in online play. - Play results will not be saved even if you use an e-AMUSEMENT PASS. - PASELI service is not available. - You cannot select "EVENT MODE" until you have set "SHOP NAME SETTINGS" and "SHOP AREA" in "GAME OPTIONS".

LCD display adjustment

The LCD display is pre-adjusted at the time of shipment.

You can adjust it as you like, but inappropriate adjustments may result in poor image quality.

So, avoid making any adjustments that are not necessary.

When making adjustments, make sure the test mode "SCREEN CHECK" (page 61) or "COLOR CHECK" (page 62) screen is displayed.



- LCD displays must be properly adjusted and operated.
- After closing the service door, be sure to lock it.

Location of LCD adjustment board

The LCD adjustment board is located on the service panel inside the service door.

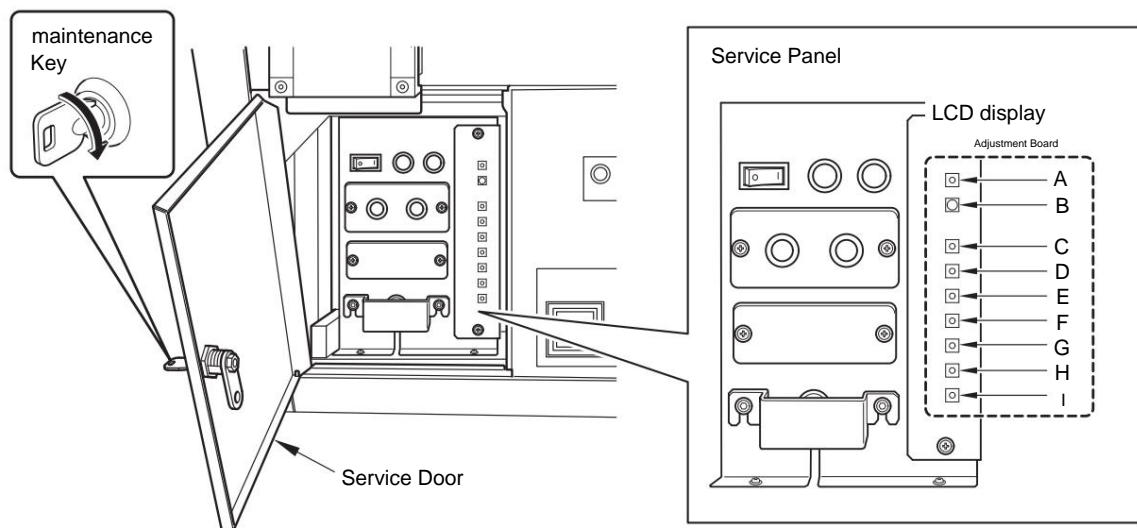

A	POWER LCD display power ON/OFF (normally ON)
B	LED The status of the LCD display is indicated by the color of the LED. • Green: Power ON • Red: Power OFF • Orange: Standby state
C	SOURCE Input signal selection (not used)
D	RIGHT Move cursor right
E	LEFT Move cursor left
F	U.P. Move cursor up
G	DOWN Move cursor down
H	SELECT OSD menu command selection (not used)
I	MENU OSD menu screen ON/OFF

MEMO • The C and H buttons are not used, so be careful not to touch them.

Automatic screen position adjustment

Adjust the screen size, vertical and horizontal misalignment, etc. (To adjust other items, refer to the procedure below and the OSD menu on page 107.)

1 Screen Check

Displaying Faces

1 Press the Test button on the service panel to activate the test mode.

2 Select "SCREEN CHECK" to display the check screen. * Be sure to do this while the test mode "SCREEN CHECK" screen is displayed. Doing this on another screen may cause the screen position or size to be shifted.

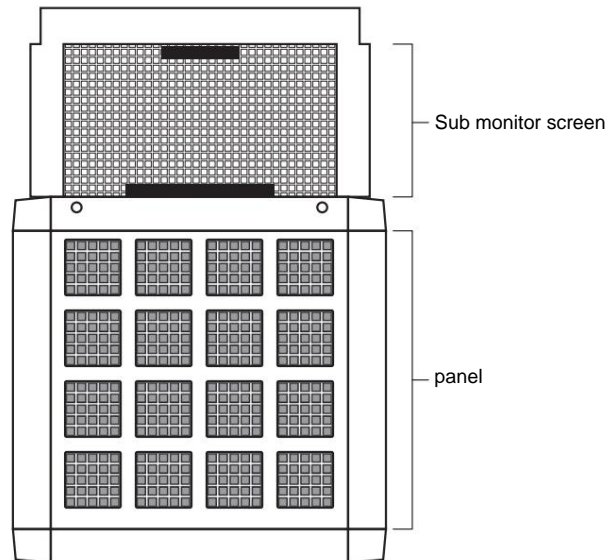
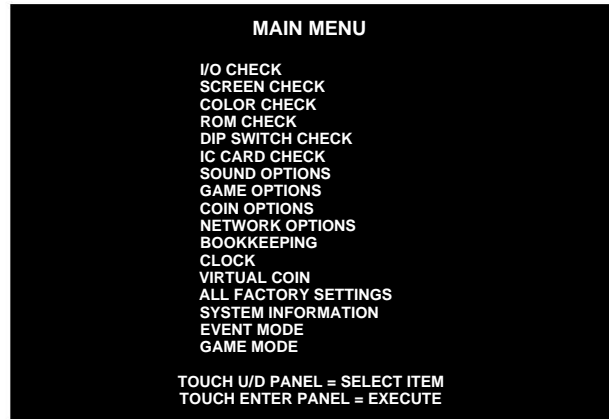

MEMO The following OSD menu screen is displayed horizontally on the panel, but it can be displayed vertically. This is due to the specifications of the spray and is not abnormal.

2 Display the OSD menu screen

do

1 Press the "MENU" button on the adjustment board. 2

The screen shown in the figure will be displayed.

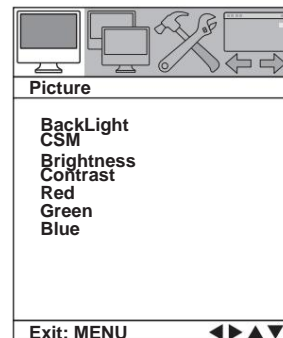
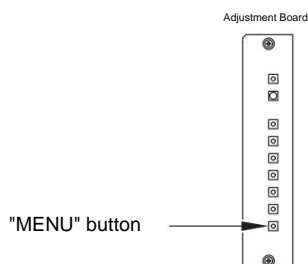

3. Select the "Screen" page

do

- 1 Press the "LEFT" or "RIGHT" button on the adjustment board. Select "Screen". The screen in Figure 2 will be displayed.

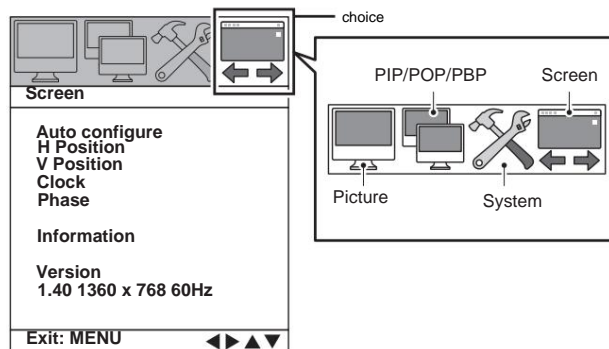
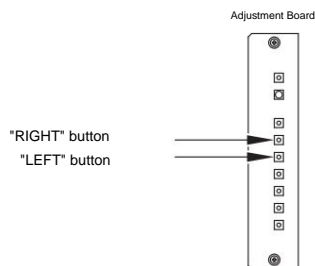

4 Automatically adjust the screen position

- 1 Press the "UP" or "DOWN" button on the adjustment board. Select "Auto-configure".

- 2 Press the "RIGHT" button.

- 3 The OSD menu screen will disappear and the adjustment will be performed automatically.

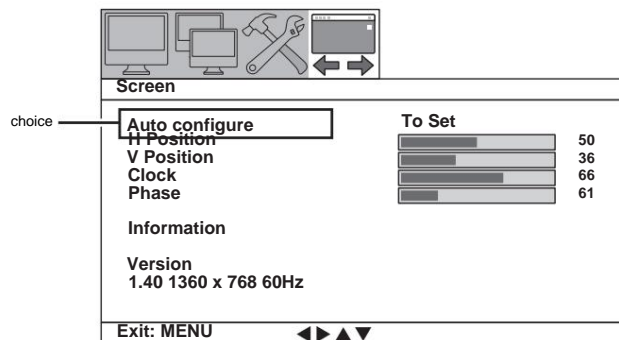
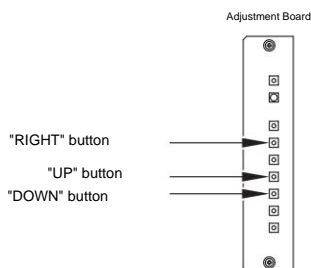

(These figures are examples.)

MEMO ÿ "Auto-configure" automatically adjusts the settings of "H-Position", "V-Position", "Clock" and "Phase" all at once.

OSD menu

Inappropriate adjustments may result in poor image quality, so please do not make any unnecessary adjustments. So lame.

If you make a mistake in the adjustments, refer to the following and reset the settings to the factory settings.

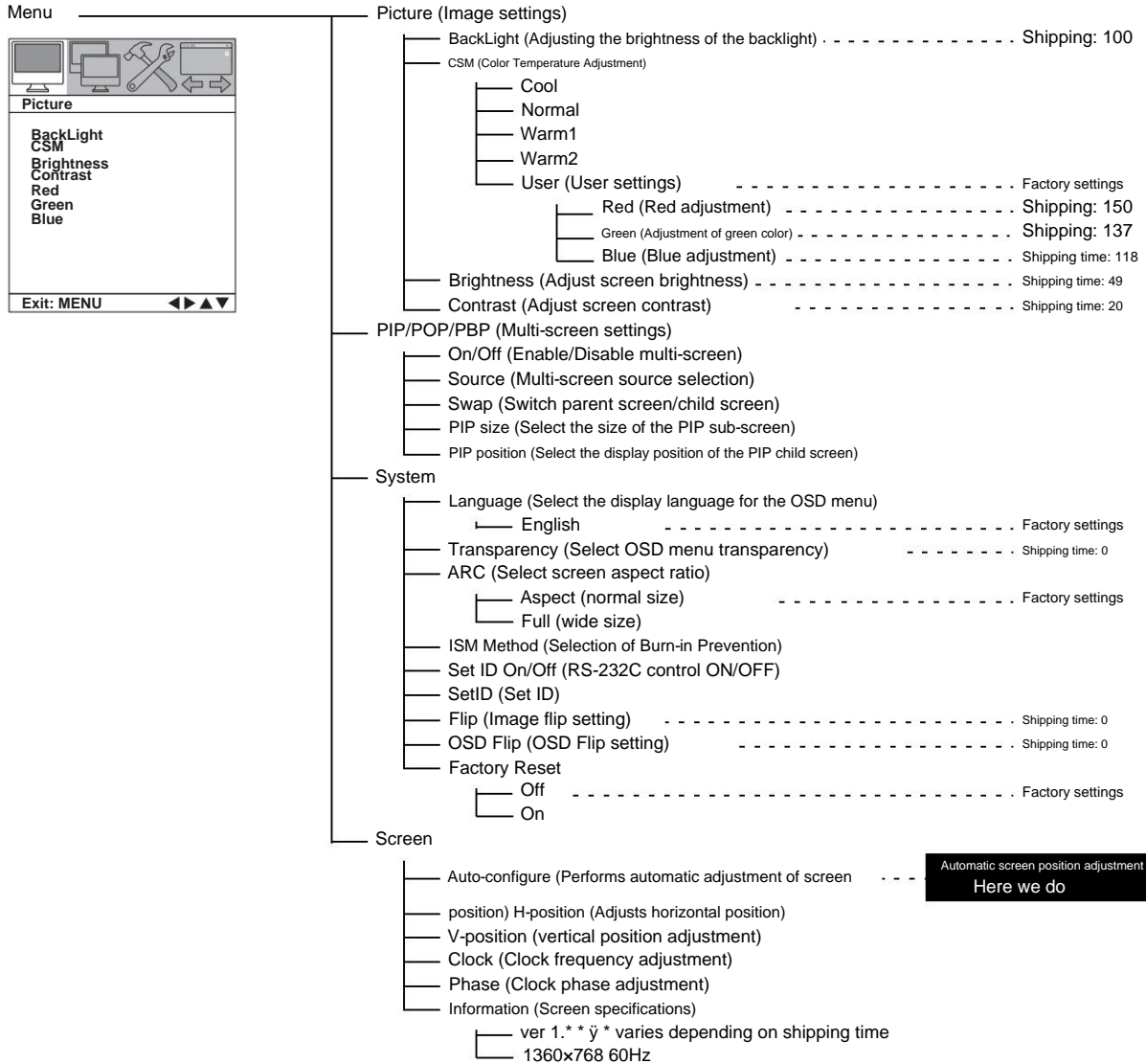

7Operation

1107 Operation

operation

Start-up inspection



Depending on the inspection content, be sure to turn off the main power switch and unplug the power cord from the outlet.

Remove

- After turning the power off, wait at least 10 seconds before turning it on again.
- Never disassemble or repair any parts not instructed in this manual.

Inspection points

Check before turning on the power (at least once a day)

Always carry out the following checks with the power turned off, and if necessary, refer to the reference pages for confirmation or Please take care of it.

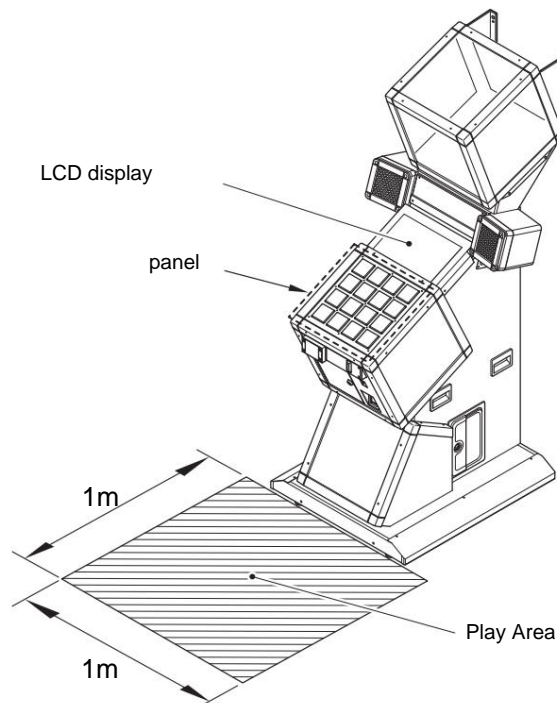

Main unit	<ul style="list-style-type: none"> • The adjuster is properly fixed and the main body Is there any wobbling? - There is no looseness or rattling in the moving parts or connections. squid. 	-
LCD display panels,	- Check that the LCD display is clean. (Page 129)	-
labels	- Check that the product is not	-
	damaged. - Check that the warning labels are not peeled off or damaged. (Page 20) squid.	-
neighborhood	Is the playing area secured?	-

Checks to be performed after turning on the power (at least once a day)

After turning on the power, check the following items and, if necessary, refer to the reference page for checking and maintenance. Please.

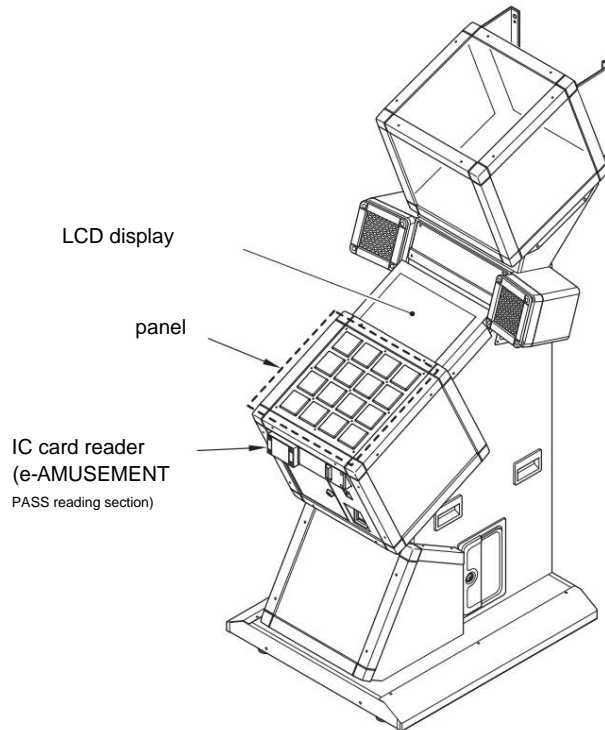

Lamps	- Check that the lamps are working properly. (ÿPage 58)	
Panel	- Is it functioning properly? (ÿPage 56)	(ÿPage 123)
LCD display	- Is there flickering or distortion on the display? (ÿPage 61)	(ÿPage 62) (ÿPage 104)
IC card reader (e-AMUSEMENT PASS Reading unit)	Is it functioning properly?	(ÿPage 65)
whole	Can you play normally?	-

Periodic Inspection



Depending on the inspection content, be sure to turn off the main power switch and unplug the power cord from the outlet.

Remove

• After turning off the power, wait at least 10 seconds before turning it on again. • Do not disassemble or repair any parts that are not instructed in this manual.

• Inspection points

Inspection to be performed before turning on the power

Always carry out the following inspection with the power turned off, and when necessary, check and maintain the product by referring to the reference pages.

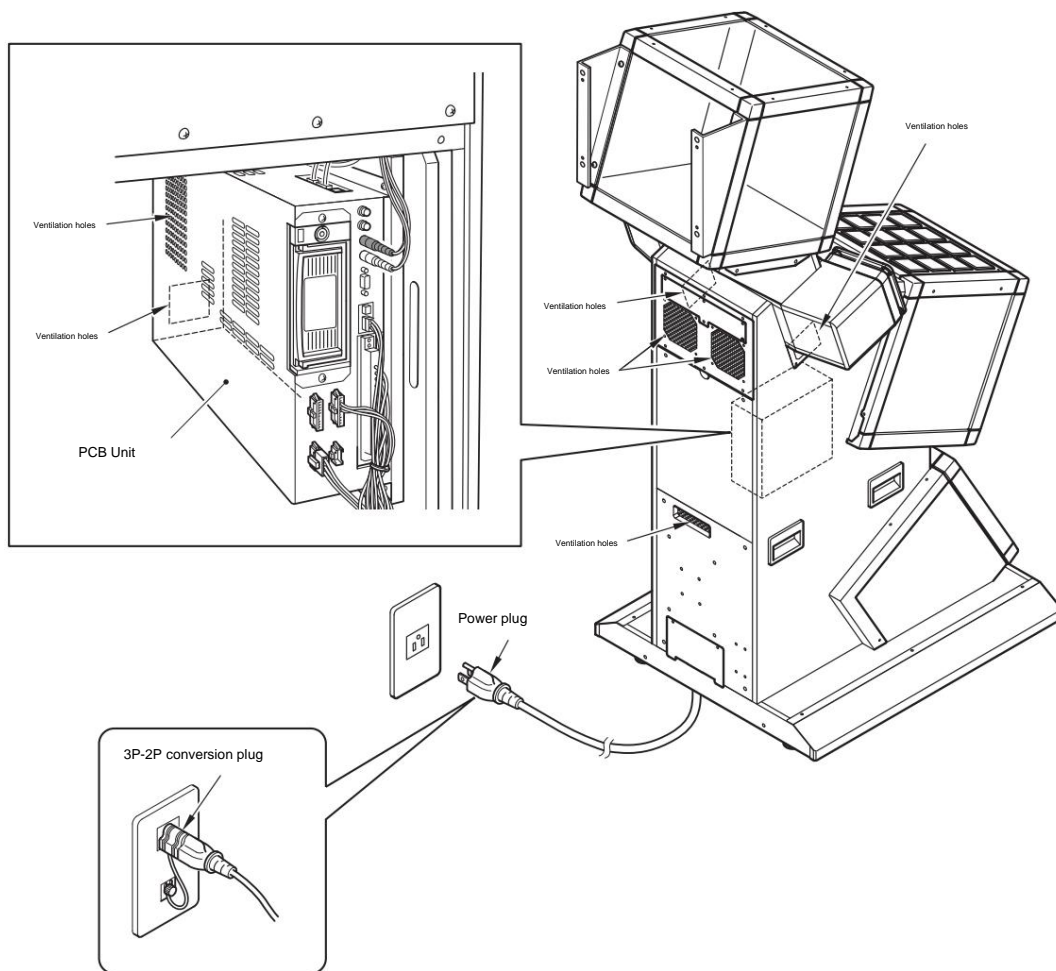

Ventilation holes (at least once every two weeks)	- Is there any dust or other buildup in the ventilation holes?	(•Pages 114 and 116)
Power plug (at least once a month)	- Is there any dust or other debris on the power plug?	(•Page 114)

8 Daily care

114 8 Daily maintenance

Daily care

Maintenance of the main unit

For items that indicate maintenance intervals, please perform the maintenance at least the specified number of times.

How to care for the product



• If you use the unit for a long period of time, parts may be deformed or damaged due to aging.

Therefore, be sure to inspect each part before operation.

• Before inspecting or maintaining this product, always turn off the main power switch and unplug it from the outlet.

Unplug the power cord from the

• After turning the power off, wait at least 10 seconds before turning it on again. • When replacing parts or consumable parts, always use parts specified by our company. Never use or mix with other parts.

• Do not disassemble, repair, set up or modify any parts not specified in this manual. • To clean the product, use a soft cloth soaked in neutral detergent and wrung out tightly before wiping. • Do not use organic solvents such as thinner, benzene or alcohol, or detergents containing abrasives. • Do not clean with a high-pressure washer, etc.

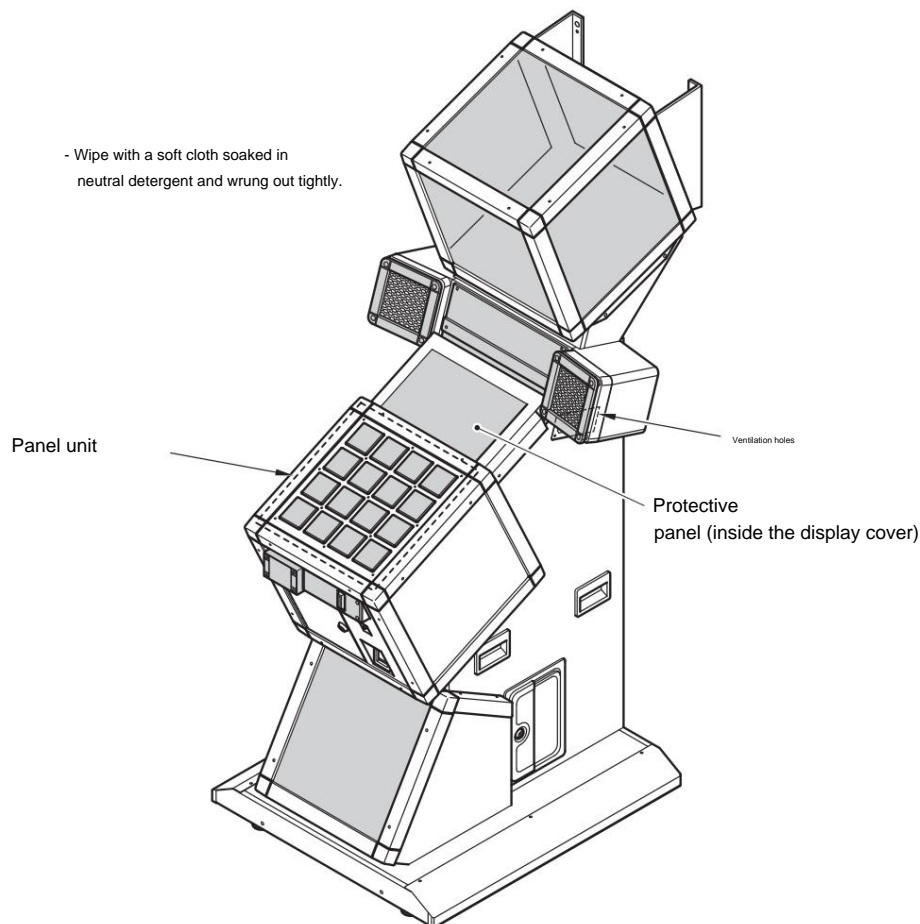

When cleaning the product, do not use alcohol, especially on the grey areas () in the illustration. This may cause damage.

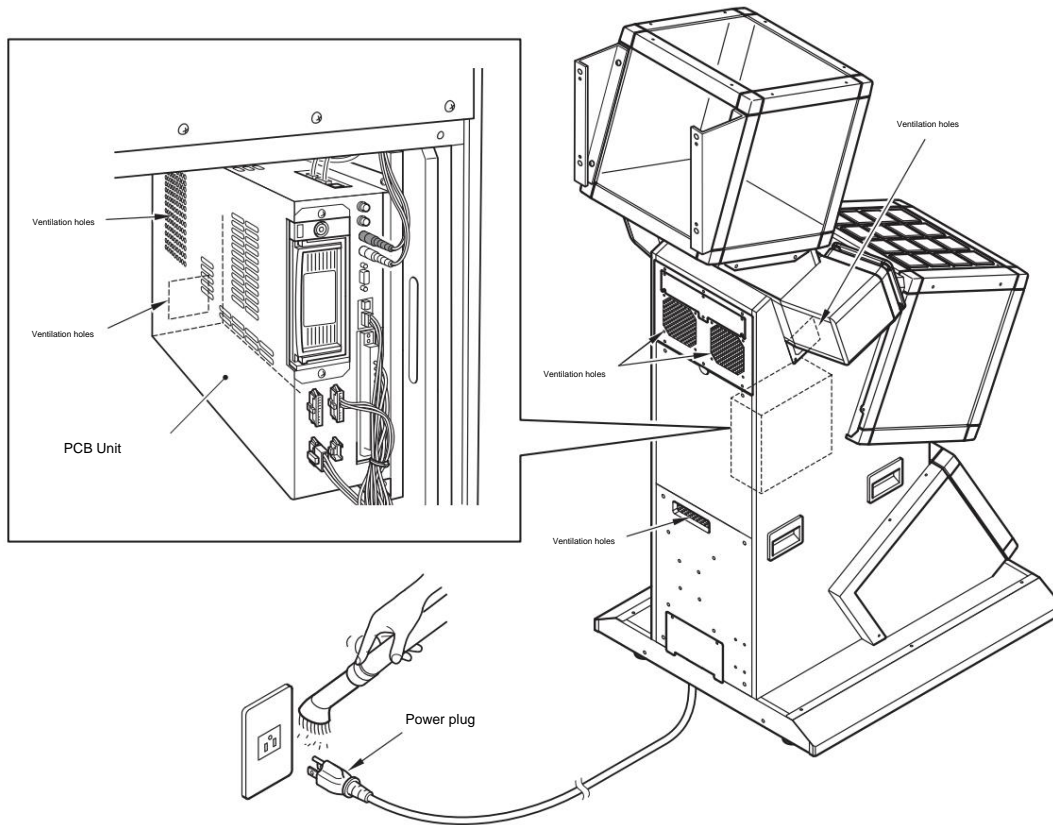

Main unit	- Use a soft cloth soaked in neutral detergent and wrung out tightly before wiping.	-
Ventilation holes (at least once every two weeks)	- Remove dust that has accumulated in the ventilation holes with a vacuum cleaner, etc. - Remove dust that has accumulated on the power plug	(ÿPage 116)
Power plug (at least once a month)	with a vacuum cleaner, etc. - Use a soft cloth soaked in neutral detergent and	-
Back side of panel unit (at least once a year)	wrung out tightly before wiping. - Use a soft cloth	(ÿPage 123)
Inside of display cover (at least once a year)	soaked in neutral detergent and wrung out tightly before wiping.	(ÿPage 129)

Cleaning the ventilation holes

How to care for the product

Follow the steps below to maintain the product at least once every two weeks.



When inspecting or maintaining the unit, always turn off the main power switch and unplug the power cord from the outlet.

After turning the power off, wait at least 10 seconds before turning it on again.



1 Turn off the power (Page 39)

1 Open the power supply unit cover on the back of the unit .

2 Turn off the main power switch and unplug the power cord from the outlet.

2. Remove dust

Remove dust from the five ventilation holes on the back and left and right sides of the unit using a vacuum cleaner or similar.

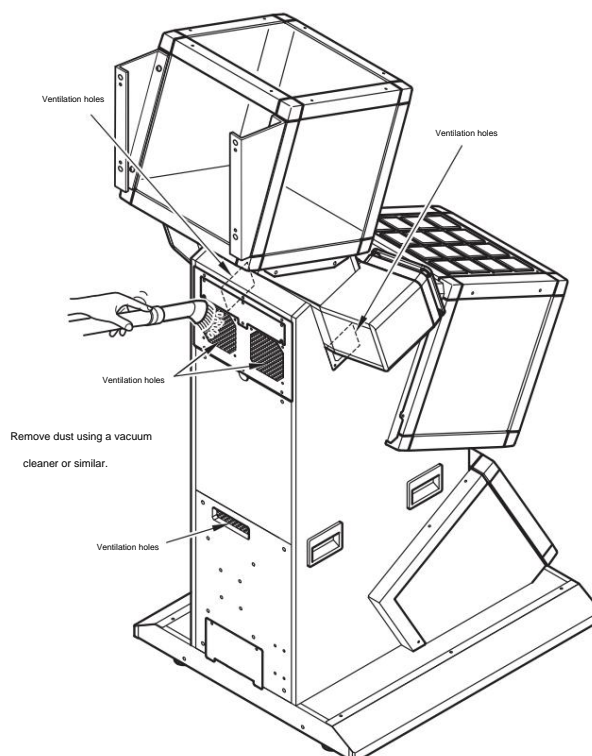

3 Open the rear door

Remove the two screws shown in the illustration to open the rear door.

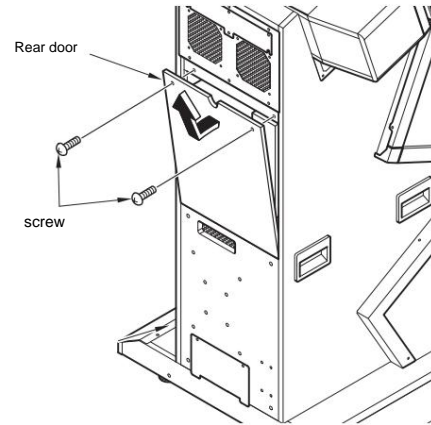

4. Wear the earth band.

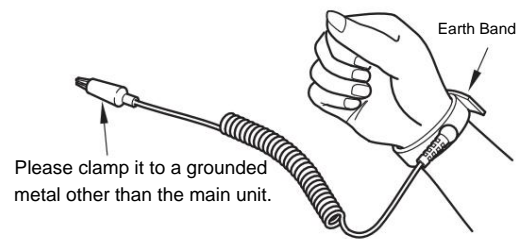

5. Unplug the connector

1. Unplug the six connectors (1 to 6) shown in the illustration that are connected to the front of the PCB unit .

How to remove connectors The method of removing a connector varies depending on the connector. Refer to the diagram below for removal.

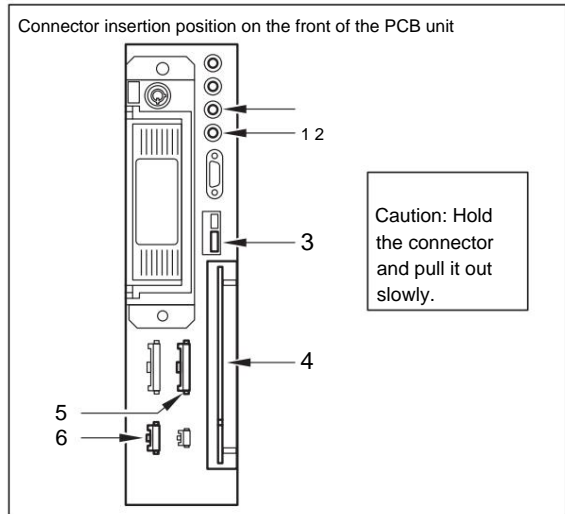
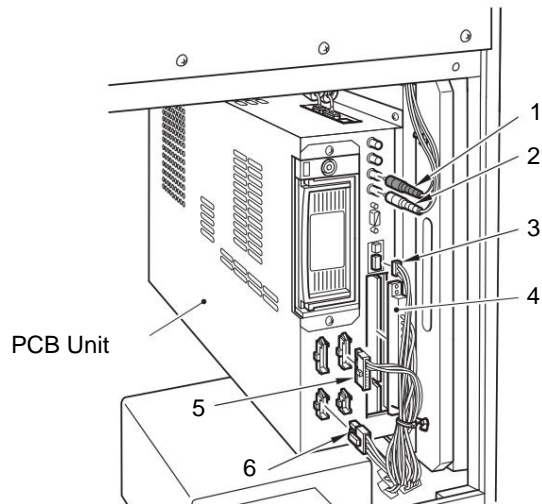
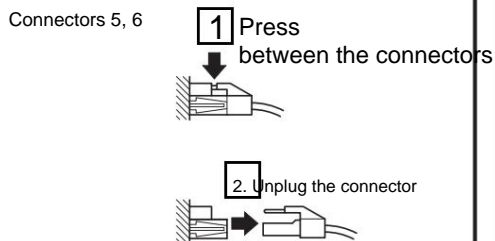
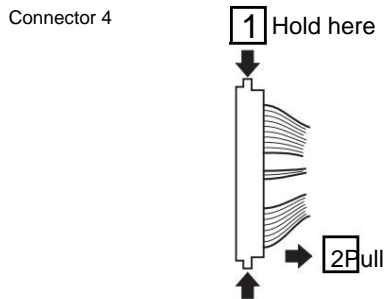
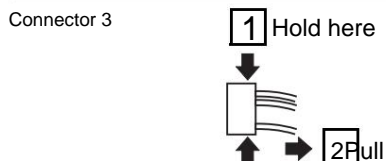
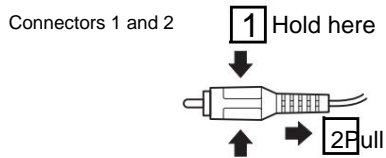

2 Remove the two thumb screws that secure the wooden board to the PCB unit. 3 Slowly pull

out the PCB unit together with the wooden board slightly from the main body (until the connectors 11 and 12 are visible). * When pulling out the PCB

unit

Be careful not to move too forcefully as this may cause the wire harness to come loose or cause internal wire breaks.

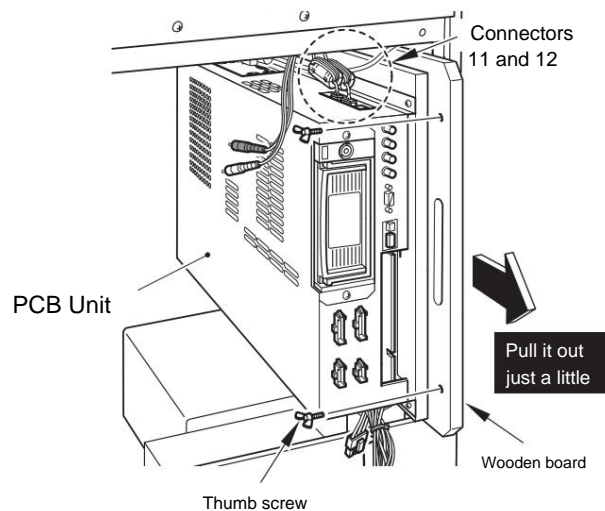

4 Unplug the six connectors (7 to 12) shown in the illustration that are connected to the top of the PCB unit.

How to remove connectors The method of removing connectors varies depending on the connector. Refer to the diagram below for

removal. Connectors 7 and 8

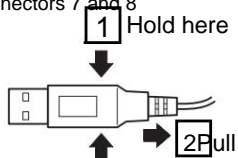

Connector 9



Connector 10

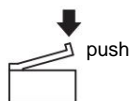

Connectors 11 and 12 Hold them here

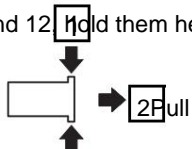

5 Remove the PCB unit together with the wooden board from the main body .

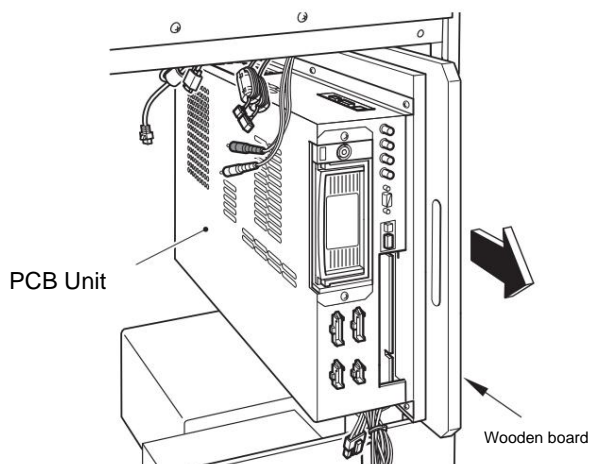
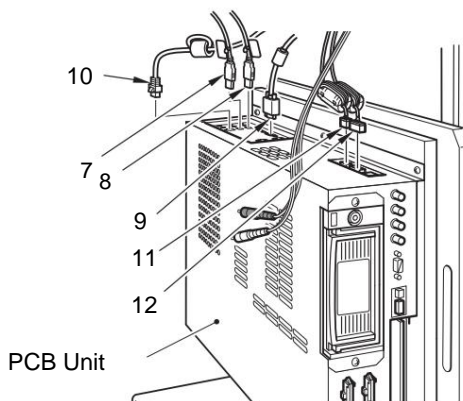

MEMO How to remove connectors When unplugging the connector, always hold the connector part. Holding the wiring may cause it to break.

6. Remove dust

Remove dust from the ventilation holes and connectors using a vacuum cleaner or similar.

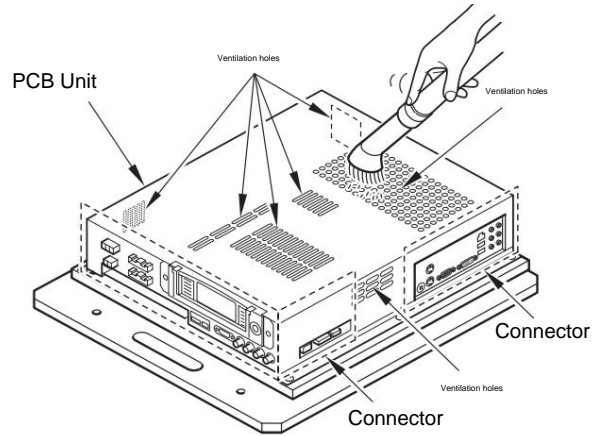

7 Check the connector connection.

Once the PCB unit is installed, it is difficult to connect the connectors on the top side. Before installing the PCB unit, check the orientation and position of the connector to be connected.

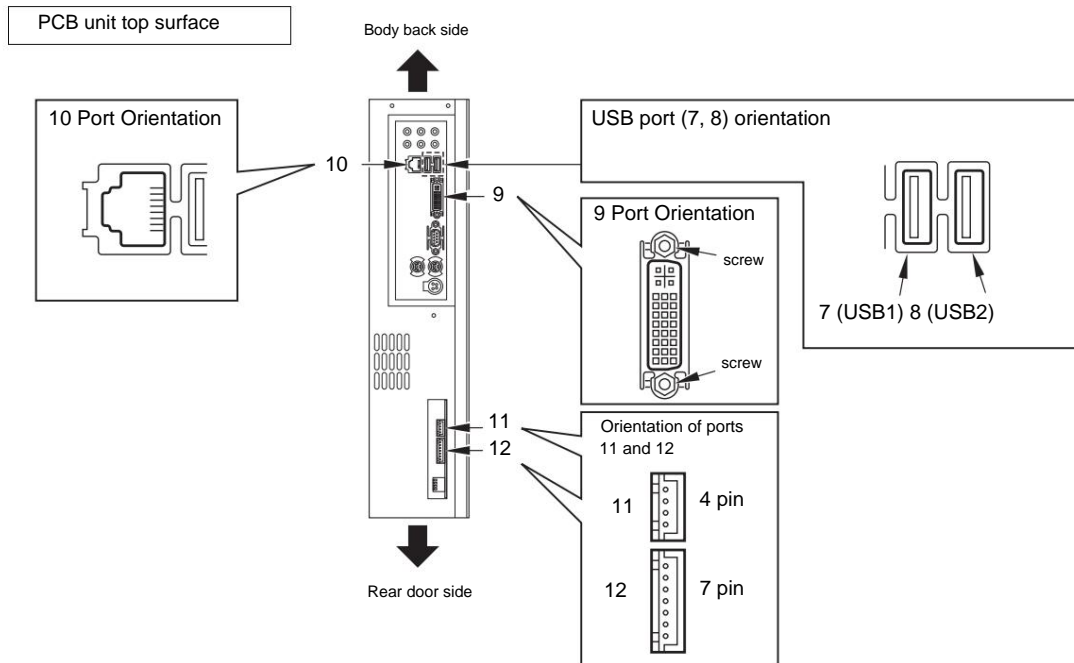

8 Install the PCB unit

1 Push the PCB unit into the position shown in the figure.

* When installing the PCB unit, be careful not to pinch the wire harness.

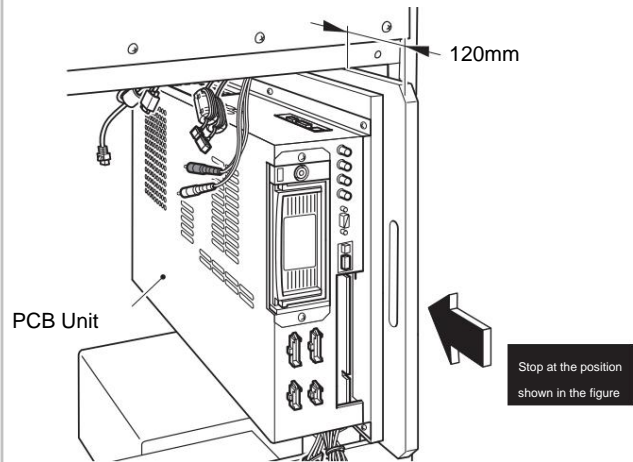

2. Connect the connectors 7 and 8 that you removed in step 5 to the two USB ports.

*Make sure to insert the connectors all the way in. Please enter.

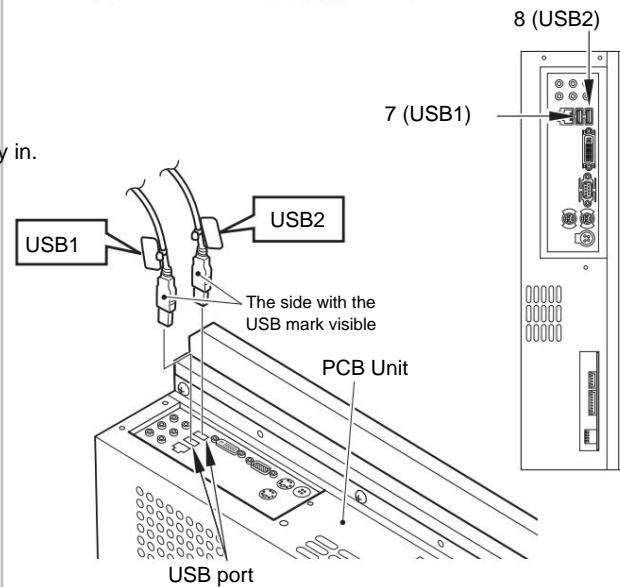

3. Connect connectors 9 and 10 that were removed in step 5 in order.

*If the harness does not reach, insert the PCB unit a little further back.

* Make sure to securely connect connector 9 with the screws.

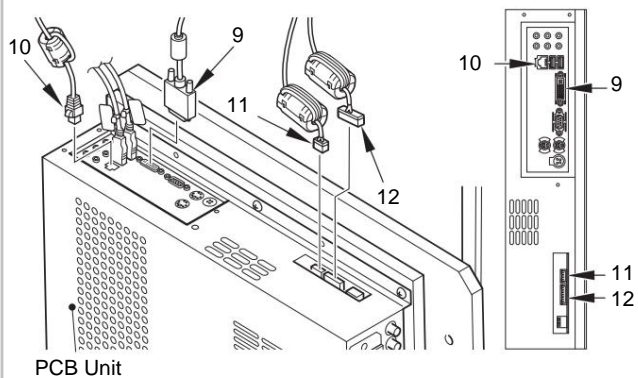
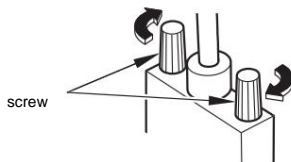

4 Next, connect connectors 11 and 12 in that order.

5 Push the PCB unit all the way in. and secure it with the two wing screws.

* When pushing in the PCB unit Be careful not to pinch the wire harness.

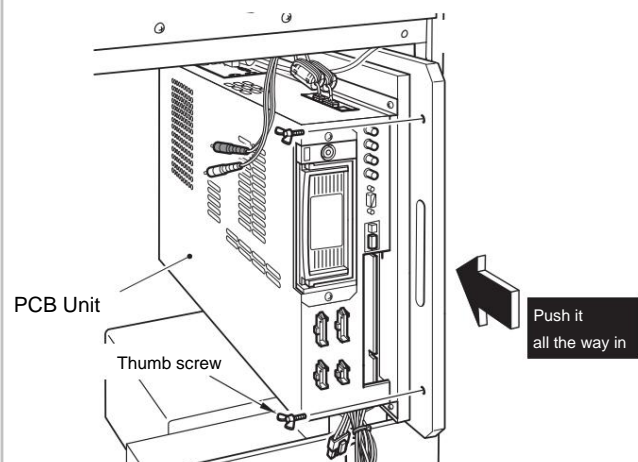

6 Reconnect connectors 1 to 6 that were disconnected in step 5 .

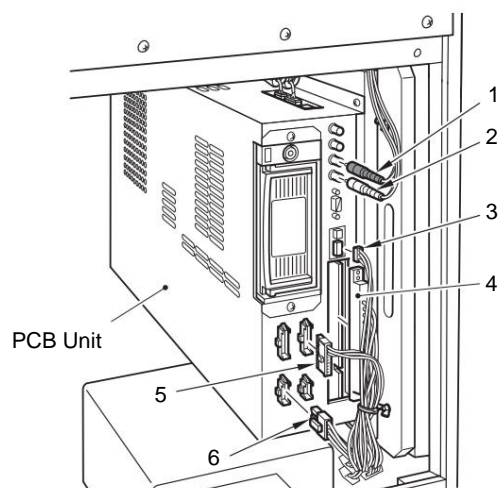

Connector insertion position on the front of the PCB unit

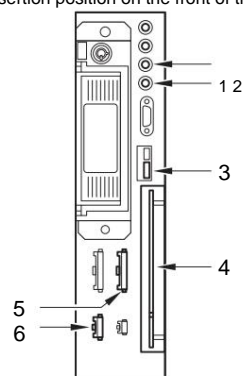

9 Close the rear door.

Secure the rear door with the screws

10 Turning the power on (ÿPage 39)

1. Plug the power cord into a power outlet and turn on the main power switch. 2. Attach the power supply unit cover to the back of the unit.

11 Check the startup

Please check that it starts up normally.

MEMO ÿ If the machine does not start up normally, turn off the main power switch, unplug the power cord from the outlet, and check that the connector is connected correctly. (ÿPage 39) * If the machine does not start up normally after taking the above measures, see "11 Troubleshooting."

Please take action as described in "Troubleshooting." (ÿPage 183)

Cleaning the rear side of the panel unit

How to care for the product

Please follow the procedure below to maintain the product at least once a year.



When inspecting or maintaining the unit, always turn off the main power switch and unplug the power cord from the outlet.

After turning the power off, wait at least 10 seconds before turning it on again. To clean the unit, use a soft cloth soaked in neutral detergent and wrung out tightly before wiping. Never use organic solvents such as thinner, benzene, or alcohol, or detergents containing abrasives.

Do not paint the buttons or attach stickers, etc. When replacing parts or consumable parts, always use products specified by our company. Never use or mix with other products.

Do not disassemble, repair, set up, or modify any part not specified in this manual. Do not clean with a high-pressure washer, etc.

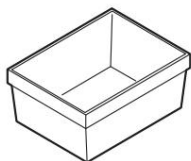

You will be removing many screws, so we recommend that you prepare several small boxes to avoid losing them.

When installing the panel unit during maintenance or other such procedures, be sure to use the original screws that were removed. Please use the



1 Turn off the power (Page 39)

1 Open the power supply unit cover on the back of the unit.

2 Turn off the main power switch and unplug the power cord from the outlet.

2 Remove the left and right covers.

1 Using a hexagonal wrench (2 mm across flats), remove the 12 long screws from the left and right covers.

*Size and shape of the removed screws (12 pieces)

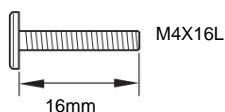

2 Remove the cover.

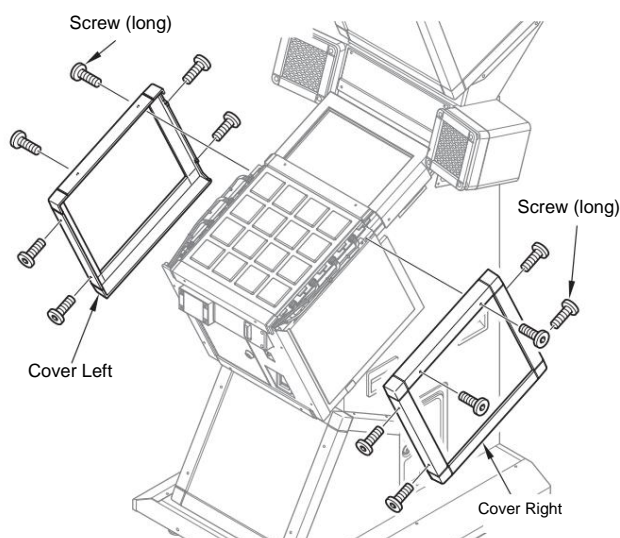

3 Remove the top and bottom covers

- Using a hexagonal wrench (2 mm across flats), remove the four short screws on the top and bottom covers. *

Check the size and shape of the four removed screws.

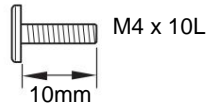

2 Remove the cover.

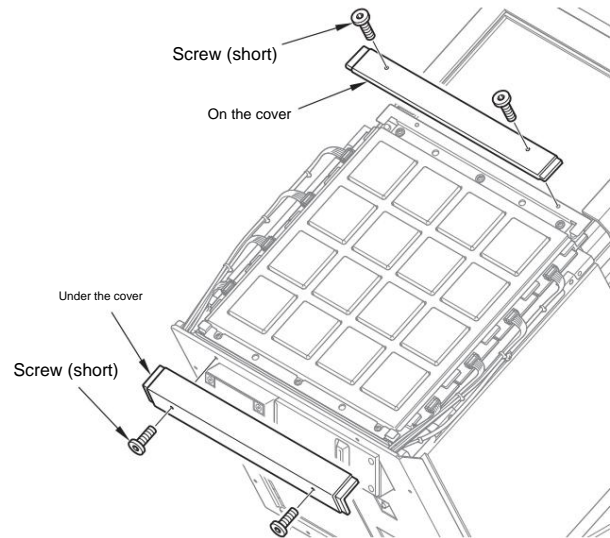

4. Unplug the connector

Disconnect the connectors (8 places) shown in the illustration that are connected to the panel unit.

- * When unplugging the connector, hold the connector and pull it out slowly.

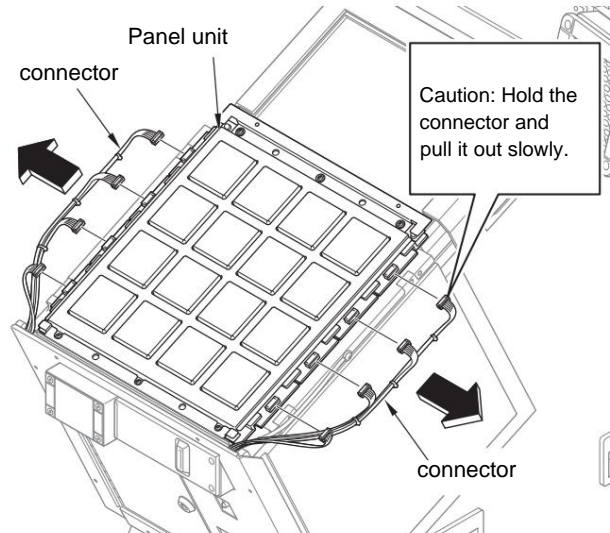

5 Remove the top and bottom screws

Remove the six screws from the top and bottom that secure the panel unit.

- *Size and shape of the removed screws (6 pieces)

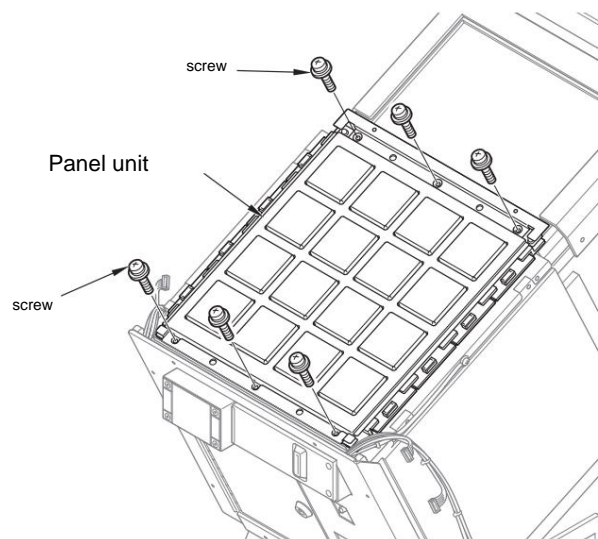
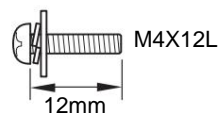

6 Remove the panel unit

Gently lift the panel unit and remove it.

Panel unit

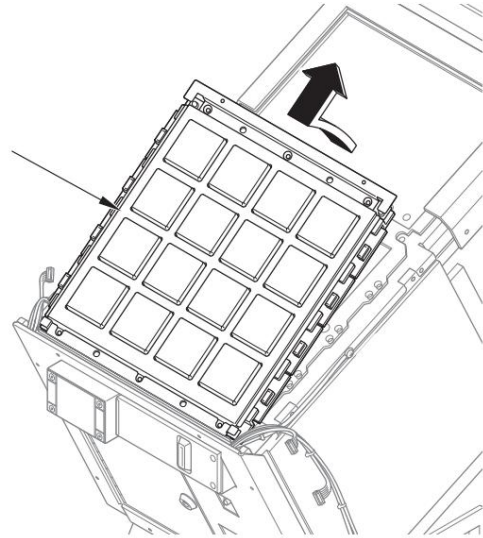

MEMO ☞ Place the panel unit on a soft cloth laid on a flat surface.

7 Wipe the back of the panel unit.

Ku

Gently wipe the back of the panel unit dry with a soft, clean cloth.

*If the stain is severe, soak a cloth in neutral detergent and wring it out tightly before wiping.

Back

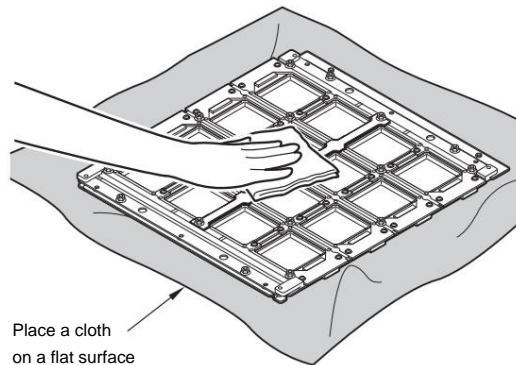

Place a cloth on a flat surface

Cleaning on an uneven surface may cause the rubber switch to become misaligned.

MEMO ☞ Using organic solvents such as thinner, benzene, alcohol, or detergents containing abrasives may cause deformation or damage to the unit. Be particularly careful not to allow any of these to come into contact with acrylic parts such as the panel. ☞ After wiping, check that the rubber switch is not out of place.

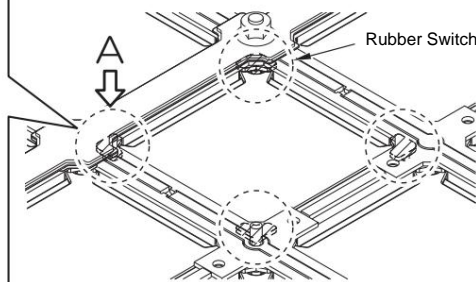
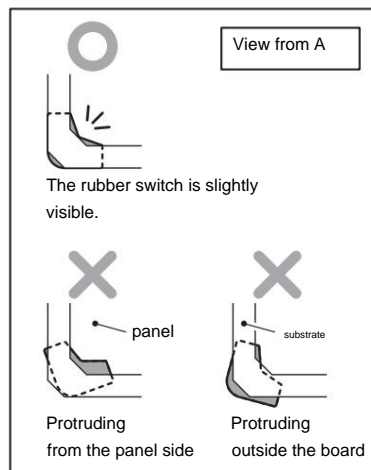

8. Install the panel unit

1. Gently insert the panel unit from the bottom of the main unit. * Be careful not to let film A slip out of place .
- 2 Secure the panel unit with the top and bottom screws removed in step 5.

Caution (Be sure to use the specified screws!)

When installing the panel unit, be careful not to use the wrong length screws.

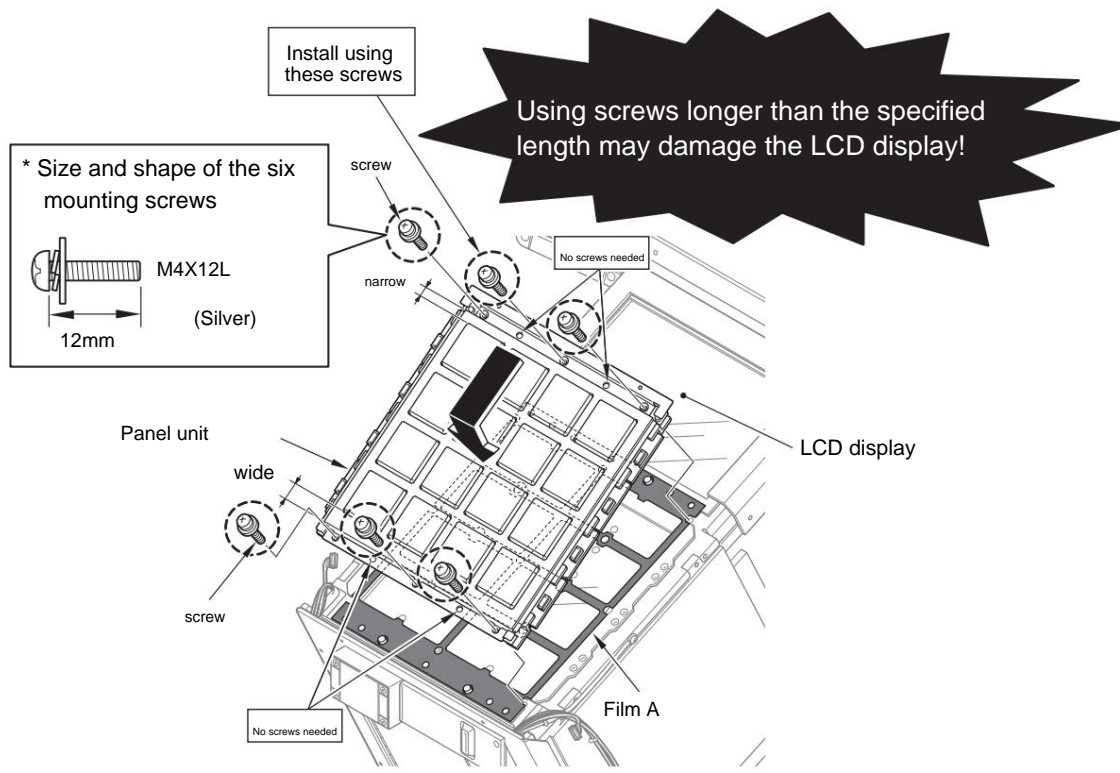

* Do not use the following screws when removing the left and right covers to attach the panel unit.



NOTE ÿ The matte side of Film A is the front. Be careful of the orientation when installing.

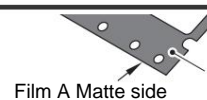

9 Connect the connector

Reconnect the connector removed in step 4 to its original position.

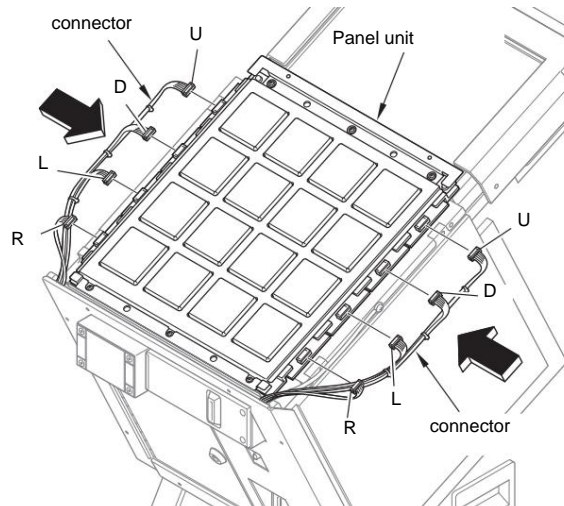

10 Attach the top and bottom covers

1 Reinstall the top and bottom covers that you removed in step 3 .

Fix it with 2 short screws.

*Size of the screws (4 pieces) to be used

and shape

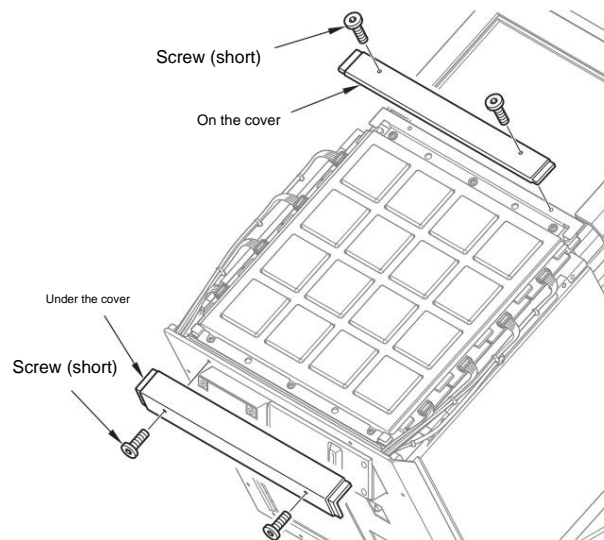
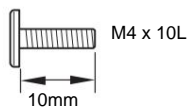

11 Attach the left and right covers

1 Reinstall the left and right covers removed in step 2 .

Secure with 2 long screws.

*There are right and left covers.

Size and shape of mounting screws (12 pieces)

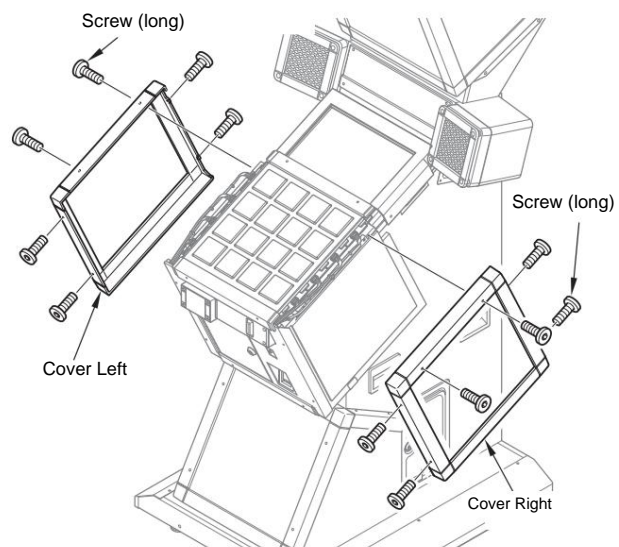
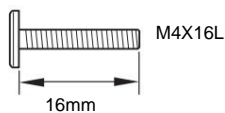

MEMO ÿ Be careful not to pinch the wire harness.

12 Turn on the power (yPage 39)

1. Connect the power plug to the outlet.
and turn on the main power switch.
- 2 Power supply unit cover on the back of the unit
Install the bracket.

13 Check the operation

- 1 Open the service door. (y Page 40) 2 Press
the test button to perform a test.
Start the mode (ypage 51) .
- 3 In the MAIN MENU, go to "I/O CHECK
>> INPUT CHECK" and select "y".
The input state of all panels
Check it out. (yPage 56 , Page 57)
- 4 After checking the operation, close the service door.
and lock it.

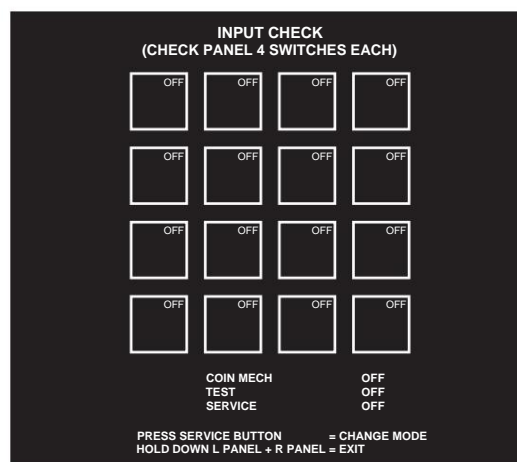

Cleaning the inside of the display cover

How to care for the product

Please perform the following maintenance at least once a year.



- When inspecting or maintaining the unit, always turn off the main power switch and unplug the power cord from the outlet.
- After turning the power off, wait at least 10 seconds before turning it on again. • For cleaning, use a soft cloth soaked in neutral detergent and wrung out tightly before wiping the unit. • Never use organic solvents such as thinner, benzene, or alcohol, or detergents containing abrasives.
- When replacing parts or replacing consumable parts, always use products specified by our company. Never use or mix any other products.
- Never disassemble, repair, set up, or modify any part not specified in this manual.

• When installing the panel unit during maintenance or other such procedures, be sure to use the original screws that were removed.
Please use the



1 Turn off the power (Page 39)

- 1 Open the power supply unit cover on the back of the unit.
- 2 Turn off the main power switch and unplug the power cord from the outlet.

2. Remove the panel unit

Refer to steps 2 to 6 in "Cleaning the back of the panel unit" (page 123) to remove the panel unit.

3 Remove film A.

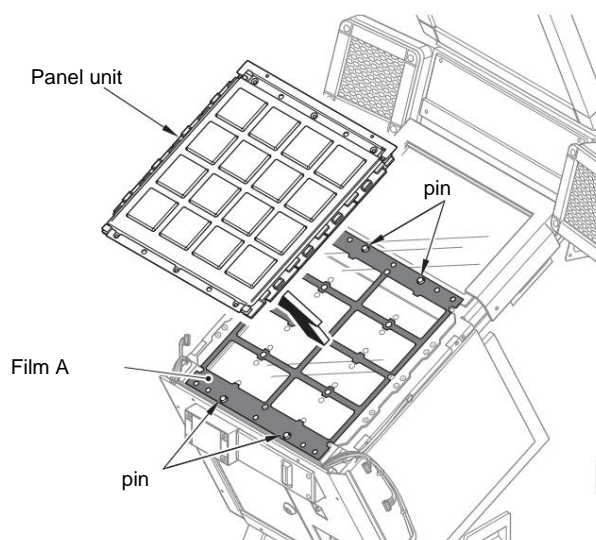

4 Remove the LCD display cover.

Remove

Remove the four screws and remove the LCD display cover.

*Size and shape of the removed screws (4 pieces)

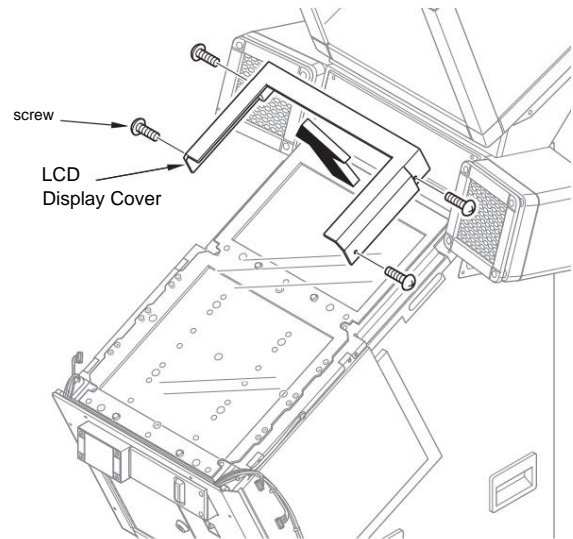
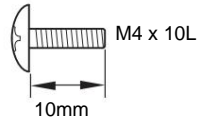
**5 Remove the transparent protective panel .**

vinegar

Remove the protection panel by lifting it upwards.

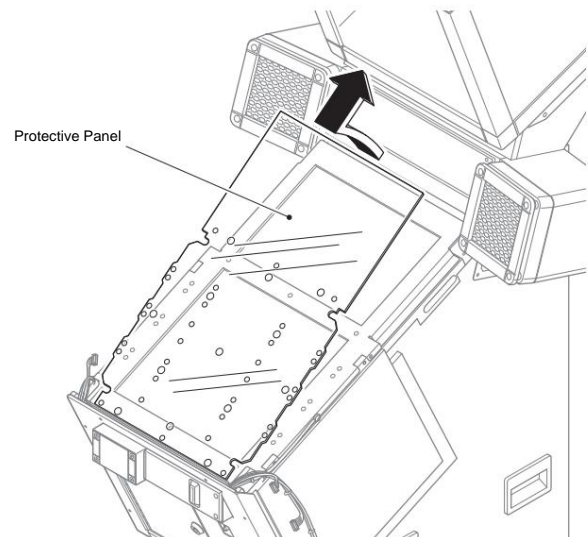
**MEMO** Place the protective panel on a soft cloth or similar.**6 Wipe the protective panel**

1. Soak a soft, clean cloth in mild detergent and wring it out thoroughly.
- 2 Wipe the protective panel.

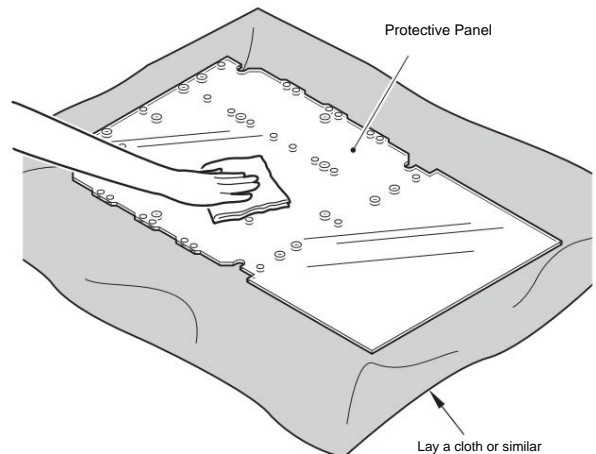

NOTE: Do not use organic solvents such as paint thinner, benzene, or alcohol, or detergents containing abrasives. Doing so may cause the main unit to deform or become damaged.

7 Wipe the LCD display

1. Soak a soft, clean cloth in mild detergent and wring it out.
2. Wipe the LCD display.

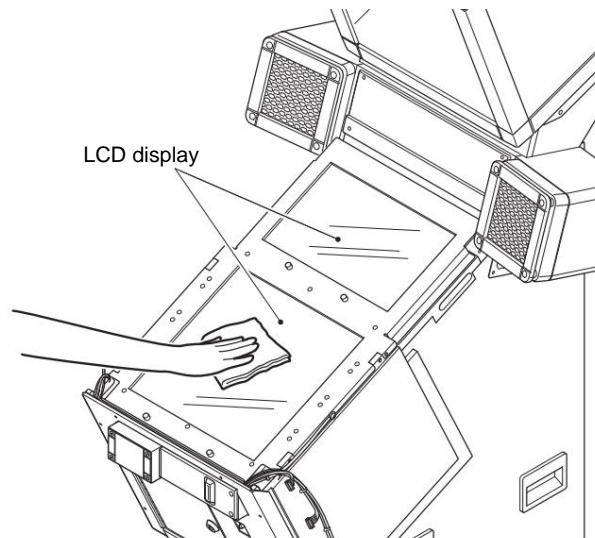

NOTE: Do not use organic solvents such as paint thinner, benzene, or alcohol, or detergents containing abrasives. Doing so may cause the main unit to deform or become damaged.

8 Place the protective panel

Place the protective panel that you removed in step 5 back onto the LCD display.

*The protective panel has no front or back.
yeah.

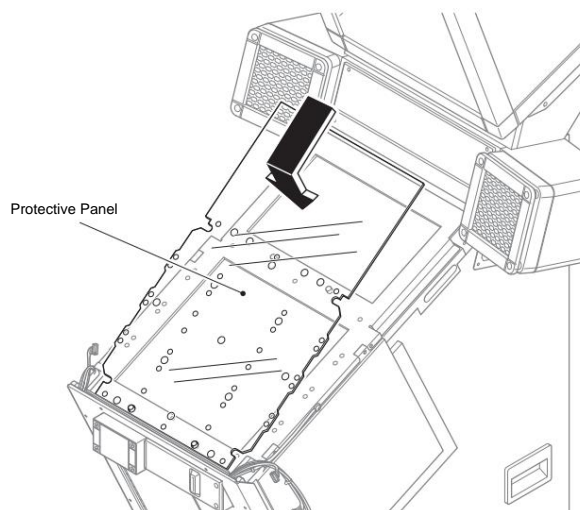

9 Remove the LCD display cover.

Install

Reinstall the LCD display cover that you removed in step 4.

*Size and shape of the four mounting screws

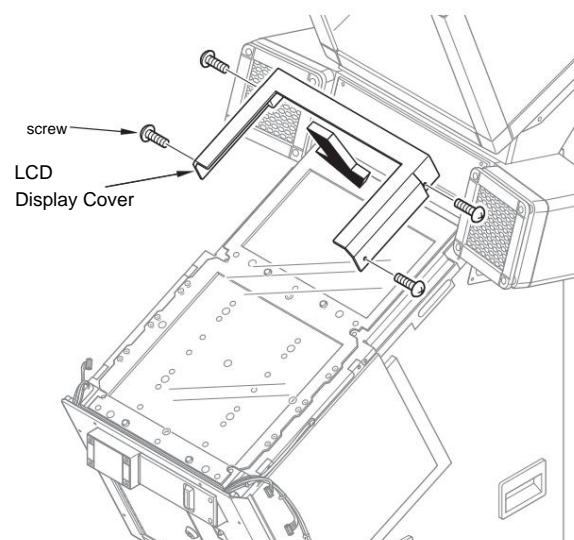
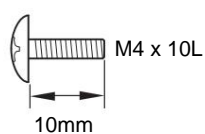

10 Film A, Panel Unit Attaching

1. Attach **film A** to the four pins.

I will attach it.

2. Maintenance of the rear side of the panel unit

Follow steps 8 to 11 of "

Refer to the following to reassemble the panel unit.

Attach it to the ground.

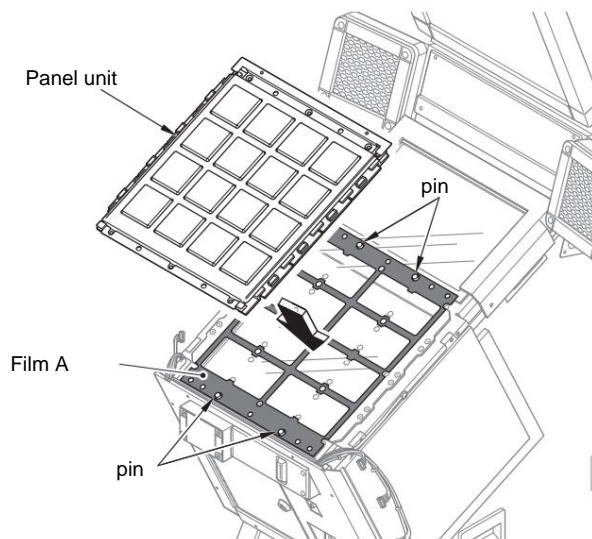

MEMO ∩ The matte side of Film A is the front.

When installing, pay attention to the orientation.

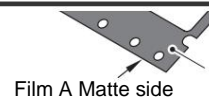

11 Turning the power on (∩Page 39)

1. Connect the power plug to the outlet.

and turn on the main power switch.

2 Power supply unit cover on the back of the unit

Install the bracket.

12 Check the operation

1 **Open** the service door.

(∩Page 40)

2 Press the test button to test

Start the mode (∩Page 51) .

3 In the MAIN MENU, select "I/O CHECK

>> INPUT CHECK" and press "∩" to

The input state of all panels

Check it out (∩Page 56 , Page 57) .

4 After checking the operation, close the service door.

and lock it.

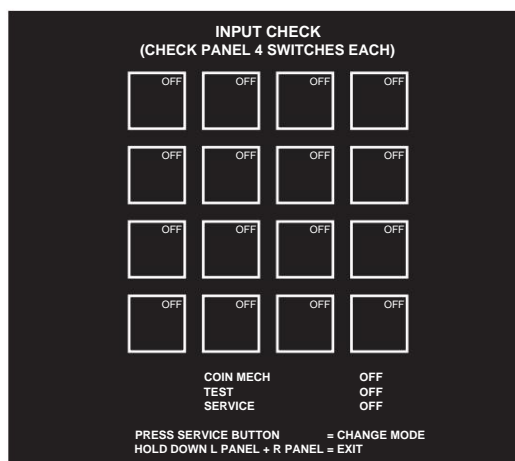

9. Installation and Assembly

"Installation and Assembly" and "Maintenance" should be read by a "Shop Maintenance Personnel" or "Technician".

134 9 Installation and Assembly

Installation and Assembly

Up to 16 units of this product can be operated in one store.

• Installation example

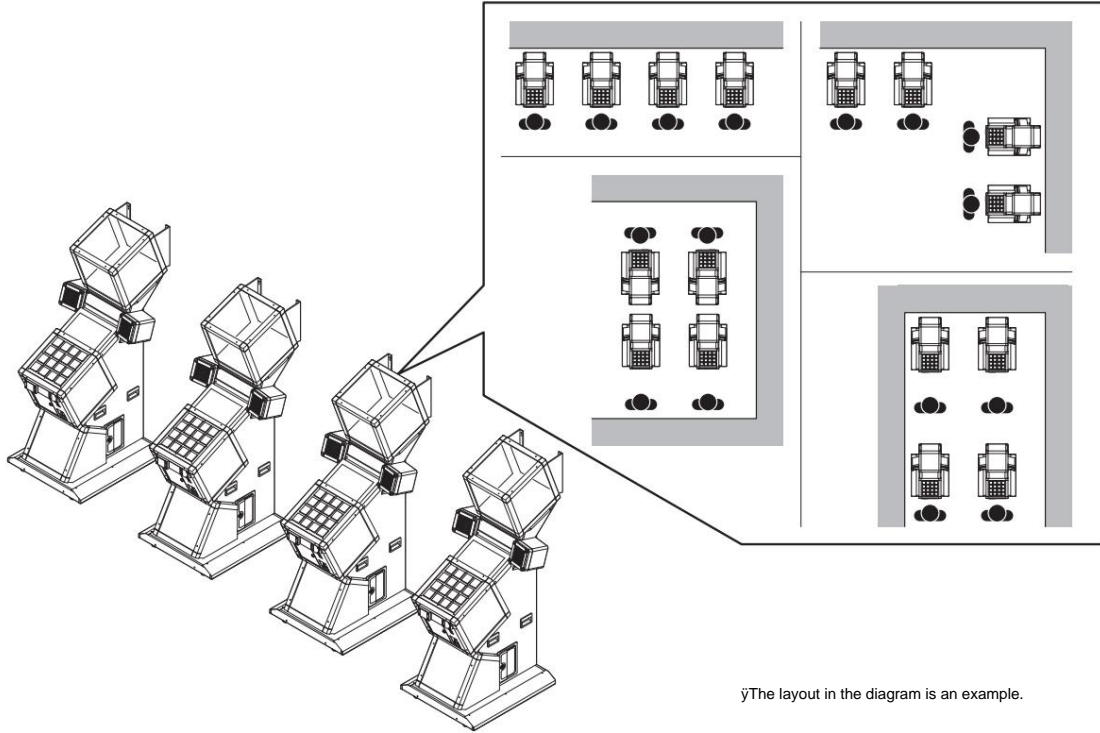

• The layout in the diagram is an example.

When installing as shown in the figure below, use commercially available
We recommend using the wiring protection cover.

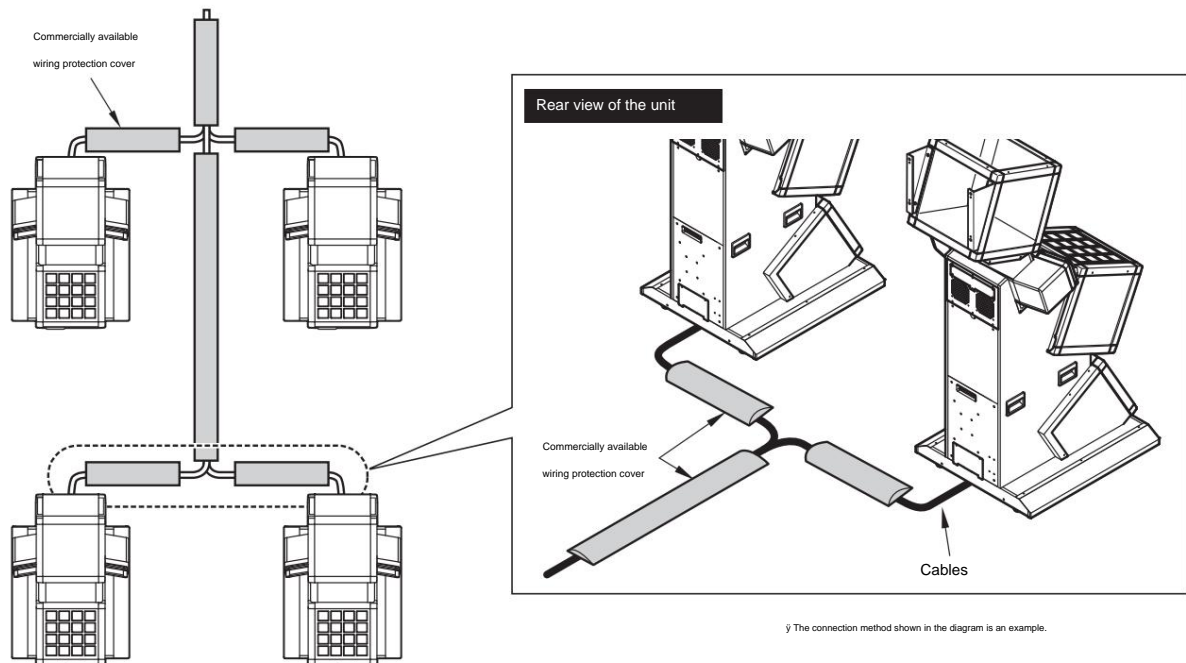

• The connection method shown in the diagram is an example.

Installation 1 Fixing the adjuster

How to fix



Adjust the adjuster so that the casters are completely off the floor. Be careful not to exceed the maximum adjustment height of the adjuster. Place the four adjusters on the floor and check that the unit is level and without any wobble, then tighten the hex nuts on the top.

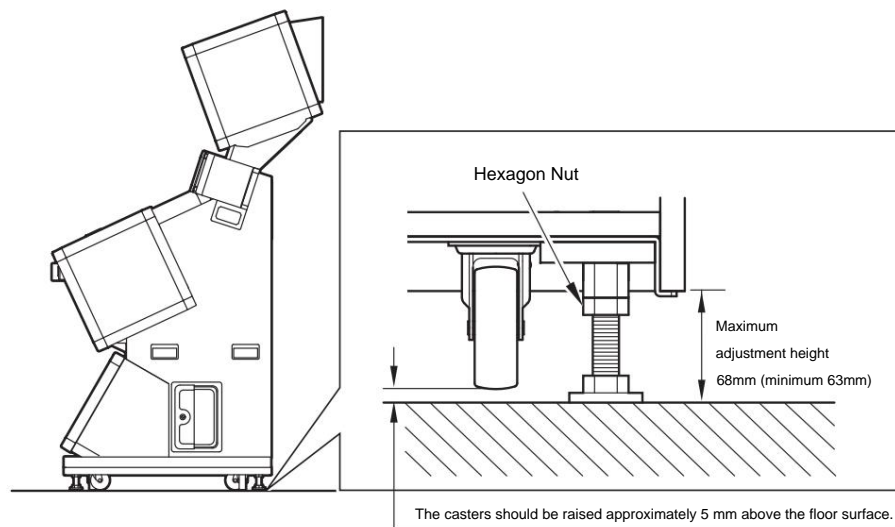

- The illustration shows the adjuster placed on the floor with the hex nut tightened on the top.

1. Ground the adjuster

Use a 24mm spanner to place the adjuster on the floor. (When removing it from the floor, turn it in the opposite direction.)

2 The casters are approximately
Check that it is lifted by 5mm.

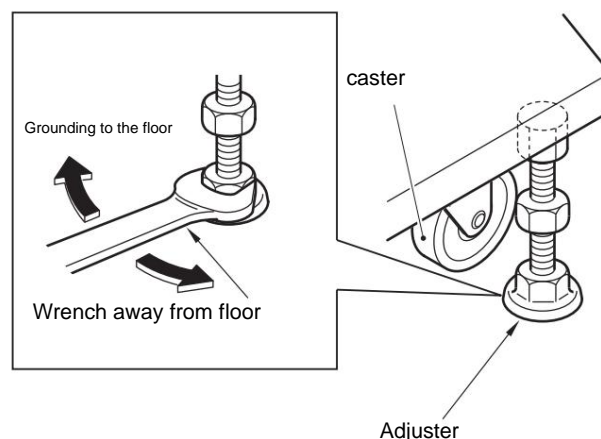

3 Check for wobble and horizontality do

After performing steps 1 and 2 for all adjusters, check that there is no wobble and that they are level.

4 All six adjusters

Tighten the square nuts

Tighten the hexagonal nut upwards
(turn it in the opposite direction to
loosen it).

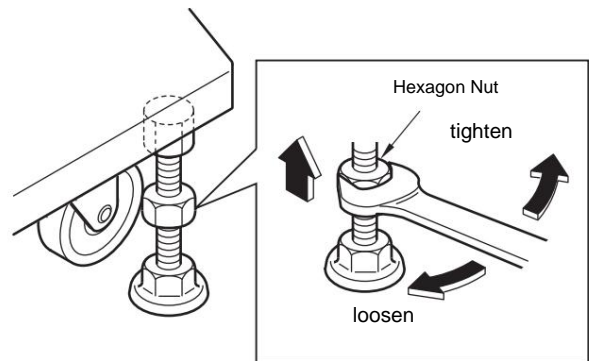

Installation 2 Set the account key and license key

How to set up



Part replacement, maintenance and inspection of this product, as well as dealing with abnormalities, should be carried out by a store maintenance staff member or technician, or requested through the after-sales service desk (fees apply). Before setting up, be sure to turn off the main power switch and unplug the power cord from the outlet. After turning the power off, wait at least 10 seconds before turning it back on. When connecting or disconnecting the power cord, wear an earth strap to prevent accidents caused by static electricity. Do not work on carpets or other surfaces. Do not get the product wet or touch the terminals.

Check that the serial number of the part you set in this section is the same as the serial number of the main unit and the LICENSE number. (Page 26)

SERIAL NO.

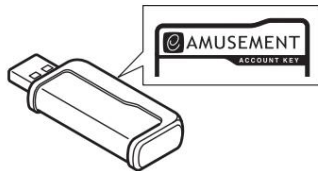

Account key (white)

SERIAL NO.

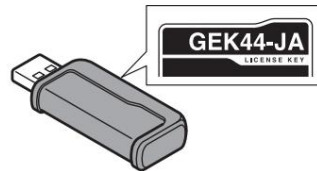

License key (black)



1 Turn off the power (Page 39)

1 Open the power supply unit cover on the back of the unit .

2 Turn off the main power switch and unplug the power cord from the outlet.

2 Open the rear door

Remove the two screws shown in the illustration to open the rear door.

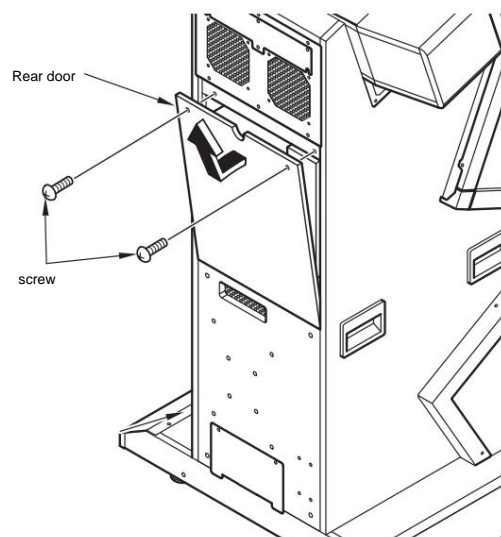

3 Wear the earth band

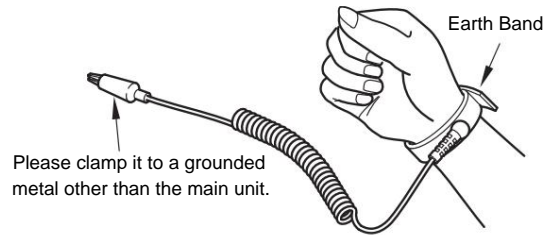

4 Account Key License Set up the keys

1 Check that the serial number of the account key and license key is the same as the number (serial number) on the specification label attached to the side of the unit (page 26).

2. Insert it in the position shown in the illustration, being careful not to make a mistake in the orientation.

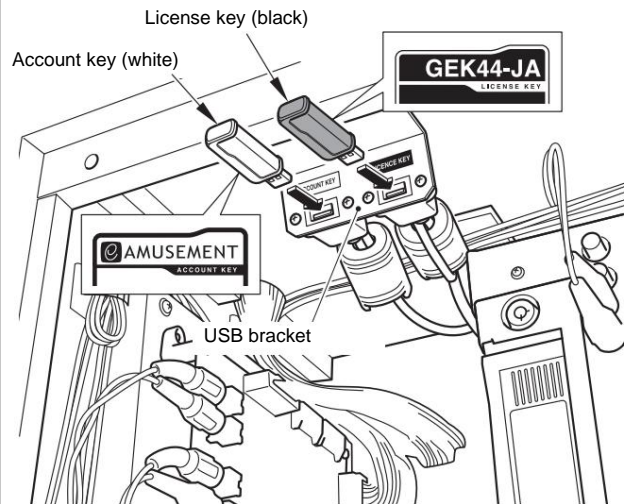
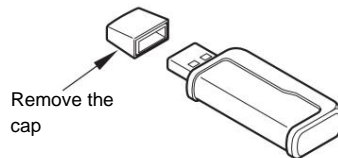

MEMO • Always use the license key and account key for this product. • Be sure to attach the license key and account key. • The "Serial number", "LICENSE NO." and "SERIAL NO." are required when contacting the after-sales service desk. • The "Serial number", "LICENSE NO." and "SERIAL NO." are the same for each unit. Do not mix units with different numbers.

5. Close the rear door.

Secure the rear door with the screws.

• This completes "Installation 2: Setting the account key and license key."
Next, perform "Installation 3: Setting the security plug (black)" (page 139).

Installation 3: Install the security plug (black)

How to set up



Part replacement, maintenance and inspection of this product, as well as dealing with abnormalities, should be carried out by a store maintenance staff member or technician, or requested through the after-sales service desk (fees apply). Before setting up, be sure to turn off the main power switch and unplug the power cord from the outlet. After turning the power off, wait at least 10 seconds before turning it back on. When connecting or disconnecting the power cord, wear an earth strap to prevent accidents caused by static electricity. Do not work on carpets or other surfaces. Do not get the product wet or touch the terminals.

Materials to be set in this item

SERIAL NO.



Security plug (black)

The serial number is printed on the label on the right side of the unit. Check that it is the same as the serial number (Page 26).



- 1 Turn off the power (Page 39)
 - 1 Open the power supply unit cover on the back of the unit .
- 2 Turn off the main power switch and unplug the power cord from the outlet.

2 Open the service door

- 1 Insert the maintenance key.

vinegar.
- 2 Turn it to the right to open the service door.

vinegar.

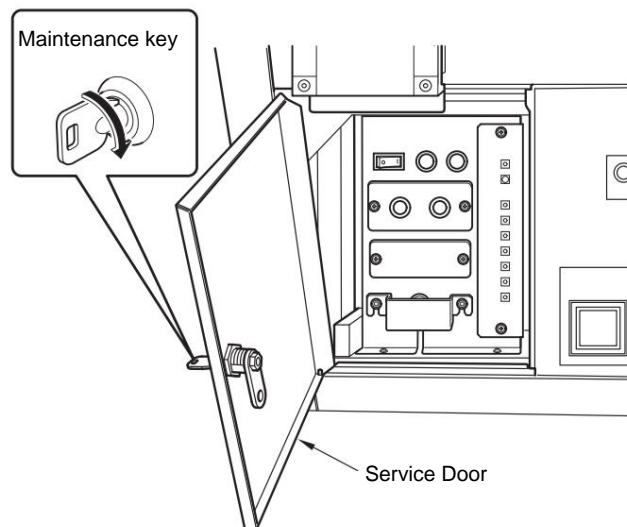

3 Wear the earth band

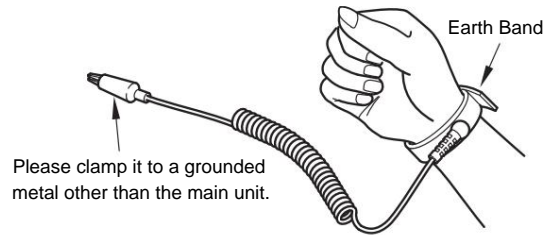

4 Remove the cover

1. Loosen the two screws on the service panel by approximately 3 mm using the included hex wrench (2.5 mm across flats).

2 Remove the cover.

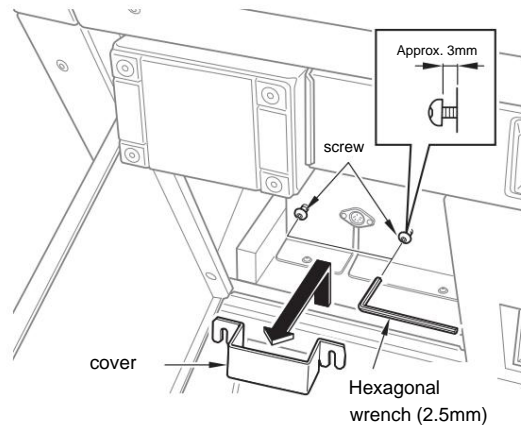

5 Security plug (black) Set the color

1 Security plug (black)

Check that the SERIAL NO. is the same as the NO. (manufacturing number) on the label showing the specifications on the side

of the unit (page 26). 2 Insert the security plug (black) into the position shown in the illustration on the service panel, making sure to observe the orientation, until you hear a click.

The part with the button is on the top.

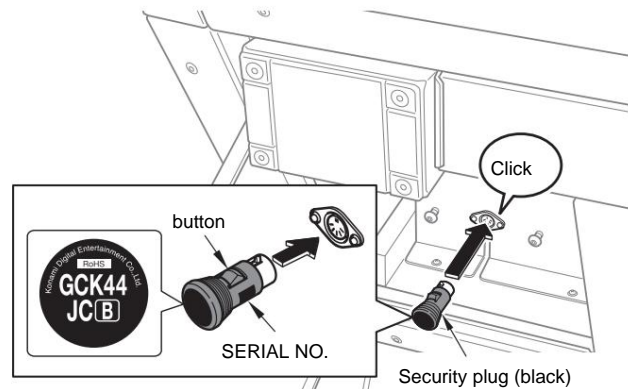

MEMO ỹ Always use the one that comes with this

product. ỹ When removing the security plug (black), press the button in the illustration and pull it out slowly. ỹ The "Serial number", "LICENSE NO." and "SERIAL NO." are required when contacting the after-sales service desk. ỹ The "Serial number", "LICENSE NO." and "SERIAL NO." are the same for each unit. Do not mix units with different numbers.

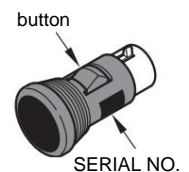

6 Attach the cover

Reattach the cover that you removed in step 4 using the screws.

7. Close the service door

ÿ This completes "Installation 3: Setting up the security plug (black)".
Next, proceed to "Installation 4: Network Connection." (ÿPage **142**)

Installation 4 Network connection

• The e-AMUSEMENT function of this product is not compatible with ISDN environments.

Please use the e-AMUSEMENT service in a broadband environment recommended by our company, such as ADSL or FTTH, and connect to the network.

• Network communication and power supply noise can interfere with each other and cause network communication errors, so when running cables around the store, keep the LAN cable and AC power cord separate.

• Even if you are not using e-AMUSEMENT, if multiple units of this product are installed in your store, you can use a separate hub and connect up to four units to the network to play wirelessly within the store.

•Connecting the LAN cable



• Before connecting the LAN cable, be sure to turn off the main power switch of the main unit and unplug the power plug from the outlet. Also unplug the power plug of any hubs. • Do not leave the LAN cable in a path where it can be stepped on or tripped over. • Do not forcibly bend the LAN cable or place objects on it. • After turning the power off, wait at least 10 seconds before turning it on again.

• Materials used

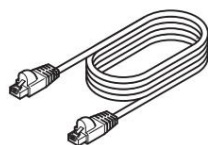

LAN cable (10m)



1 Turn off the power (•Page 39)

1. Open the power supply unit cover on the back of the unit.
2. **Turn** off the main power switch and unplug the power cord from the outlet.

2 Connect the LAN cable (•Page 143)

To use e-AMUSEMENT, connect the LAN port on the back to the hub on the e-AMUSEMENT side.

If you are not using e-AMUSEMENT, connect the LAN port on the back to the hub for in-store online play.

* Before connecting the LAN cable, remove the power supply unit cover. (•Page 39)

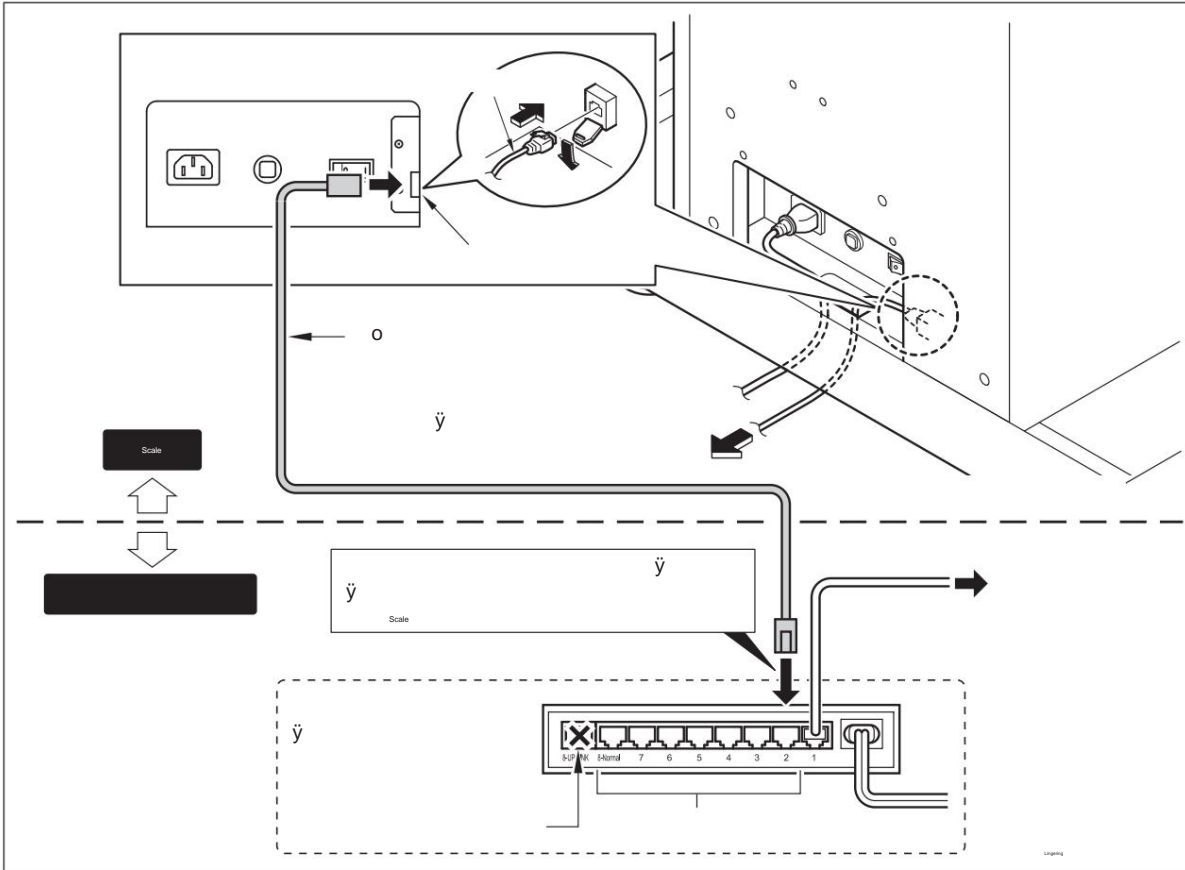

ü ü

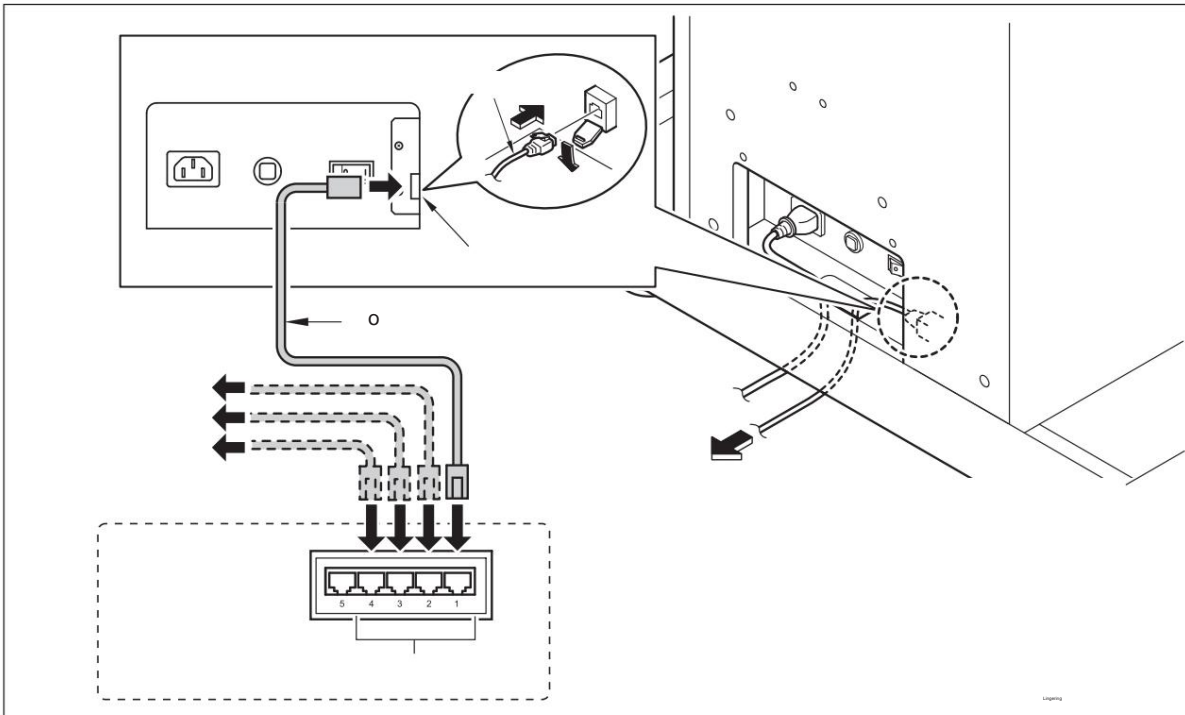

MEMO ÿ If the length of the LAN cable is insufficient, please prepare a cable of the required length that meets the specifications below.

LAN cable

specifications - Category 5 or 6 straight-through type (including enhanced category 5 or 6 straight-through type)

LAN cable length

- The shorter the LAN cable, the more stable the communication speed. Even if a longer cable is required due to the installation conditions, keep the cable length under 100m. Even if the cable is less than 100m, using a long cable may cause communication errors, so keep the length from the main unit to the in-store e-AMUSEMENT hub as short as possible. Also, when connecting to the network by adding a hub, keep the length between the in-store e-AMUSEMENT hub and the additional hub as short as possible, and keep it to a maximum of 100m.

Installation 5 Confirmation of e-AMUSEMENT service usage

This item is displayed to confirm whether or not you want to use the e-AMUSEMENT service after installation.

• Once you have confirmed this after installation, it will not be

displayed again. (If you move to another store, the "Confirm e-AMUSEMENT service usage" will be displayed again.) • It will not be displayed if you are not connected to the network with a VPN router.

Please check by following the procedure below. • If you

use the e-AMUSEMENT service • Go to step 1 below. • If you do not use the e-AMUSEMENT service • Go to step 1 on page 147 .

When using the e-AMUSEMENT service

1 Check the network

Check that the LAN cable is connected between the LAN port on the main unit and the e-AMUSEMENT hub in the store. (See "Connecting the LAN cable") (•Page 142)

2 Start the program (•Page 39)

Turn on the main power switch to start up.

*Start-up takes about 3 minutes.

3. e-AMUSEMENT Service

Confirm the use of

1The screen shown in the figure will

be displayed. **2**Open the service door. (•Page 40)

3 While pressing the SERVICE button on the service panel, press the TEST button.

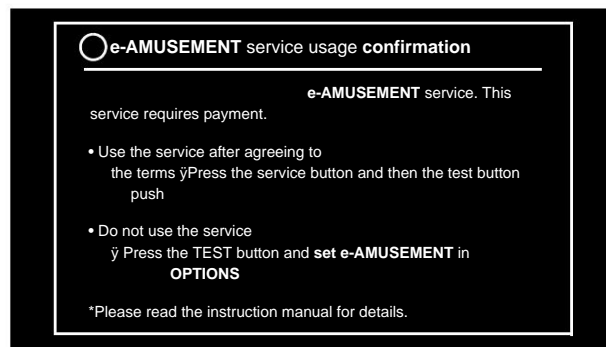

MEMO • If you are not using the e-AMUSEMENT service, press the TEST button on this screen. If you are not using the e-AMUSEMENT service • Go to step 5 on page 148.

MEMO ý About the service panel

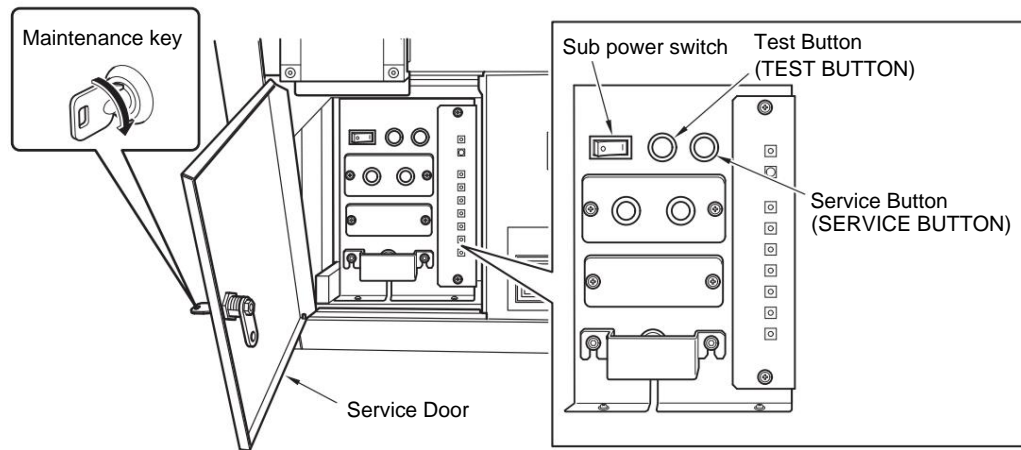

4. e-AMUSEMENT Service

Recheck the use of

- 1A** reconfirmation screen will appear.
Press and hold the Service button again and then press the Test button.
- 2** Test mode will start.

i e-AMUSEMENT service usage confirmation

yyyyyyyyyyyy Reconfirm yyyyyyyyyy Are you sure?

Yes, I want to use the service.

Press the service button and then press the test button.
push

• No, I don't want to use the service ý

Press the TEST button and set e-AMUSEMENT in
OPTIONS

MEMO ý If you are not using the e-AMUSEMENT service, press the TEST button on this screen. If you are not using the e-AMUSEMENT service ý Go to step 5 on page **148**.

ý This completes "Installation 5: Confirmation of e-AMUSEMENT service usage."
Next, proceed to "Installation 6: Initial startup settings." (ýPage **150**)

If you do not use the e-AMUSEMENT service

1 Check the network

Make sure that the LAN cable between the LAN port on the main unit and the e-AMUSEMENT hub in the store is not connected

(**Page 142**).

*If you unplug the LAN cable, be sure to restart the system.

2 Start the program (**Page 39**)

Turn on the main power switch to start up.

* It takes about 4 minutes to start up.

3 An error screen appears

Since there is no network connection with e-AMUSEMENT, the screen shown in the figure will be displayed.



MEMO

• If you are connected to the e-AMUSEMENT network, the screen shown in the figure will be displayed.
In that case, after performing steps 4 to 6 below, unplug the LAN cable between the LAN port of the main unit and the e-AMUSEMENT hub in the store, and be sure to restart the system.

i e-AMUSEMENT service usage confirmation

e-AMUSEMENT service. This service requires payment.

- Use the service after agreeing to the terms • Press the service button and then the test button push
- Do not use the service
• Press the TEST button and set e-AMUSEMENT in **OPTIONS**

*Please read the instruction manual for details.

4 Press the test button

- 1 **Open** the service door (page 40).
- 2 **Press** the test button on the service panel.

MEMO About the service panel

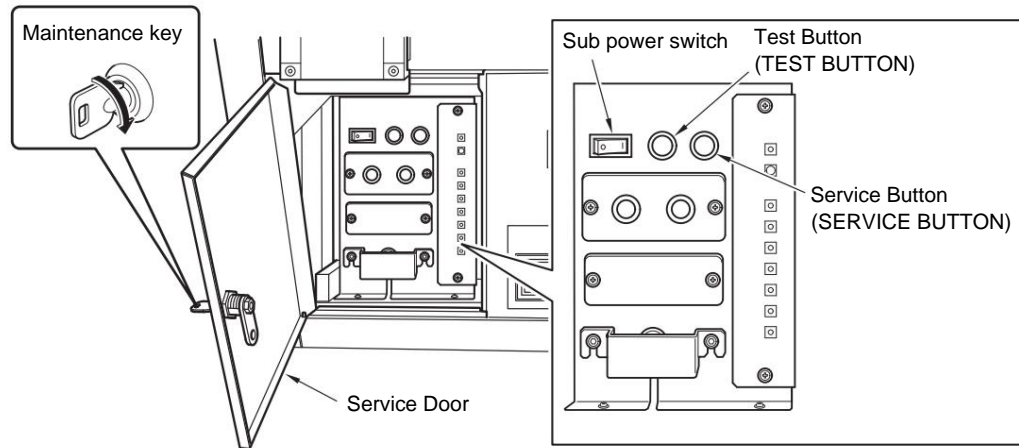

5 Test mode starts

The test mode will start and the "MAIN MENU" will be displayed on the screen.

- * For GAME OPTIONS settings, see "Initial startup settings" (page 150).
- * For information on how to use the test mode, see page 52.

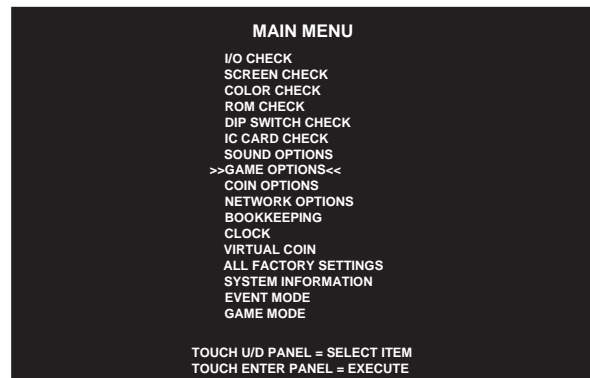

6. NETWORK OPTIONS

Configure the settings

- 1 Select "NETWORK OPTIONS" and set "e-AMUSEMENT" to "OFF."
- 2 **Next**, change "DHCP" to "NOT USE".
- 3 Select "SAVE AND EXIT" Touch the ENTER panel.

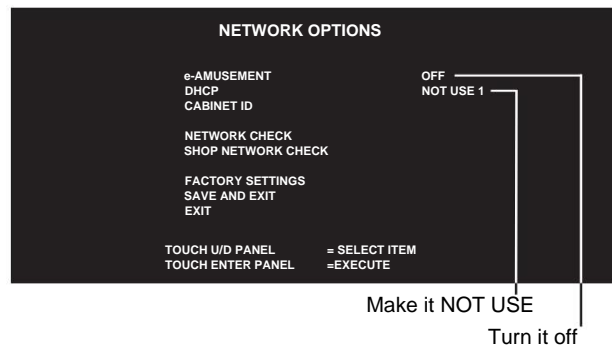

MEMO Before proceeding to restart in step 7, if a LAN cable is connected between the LAN port of the main unit and the e-AMUSEMENT hub in the store, unplug the LAN cable.

7. Reboot

1 Turn off the main power switch, wait 10 seconds or more, then turn it on to restart the unit. 2 The test mode will start.

ÿ This completes "Installation 5: Confirmation of e-AMUSEMENT service usage."
Next, proceed to "Installation 6: Initial startup settings." (ÿPage **150**)

Installation 6 Initial startup settings

When using this product for the first time or after initializing (returning to the factory settings), be sure to refer to "6 Game Settings" and perform the following settings.



After turning the power off, wait at least 10 seconds before turning it on again.

1 Check that the test mode is running

do

Make sure the MAIN MENU is displayed on the screen.

* Please refer to page 52 for instructions on how to operate the test mode .

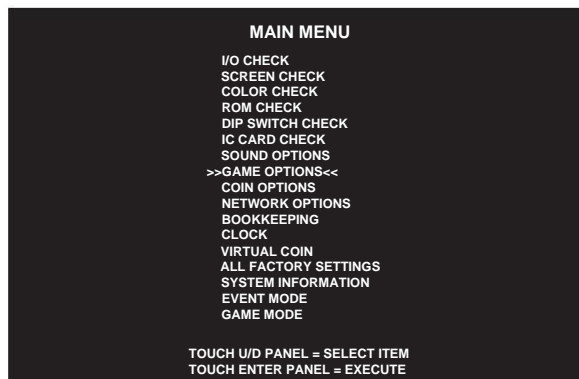

2. Register your store name and area

Register the following items. -

Registering the

store name "GAME OPTIONS >> SHOP SETTINGS >> SHOP NAME SETTINGS" (Page 70)

- Registering

the area "GAME OPTIONS >> SHOP SETTINGS >> SHOP AREA" (Page 69)

MEMO: You cannot select "GAME MODE" or "EVENT MODE" until you have set "SHOP NAME SETTINGS" and "SHOP AREA".

3. Setting the number of communication devices within the store

Configure the following items:

"GAME OPTIONS >> PLAY SETTINGS >> MAX MEMBER (LOCAL)" (Page 68)

4. Configure various settings

Check each item in the test mode and set various items. (Page 53) If you have multiple units installed, please set "NETWORK OPTIONS >> CABINET ID".

Please check the settings. (Page 74)

Customers who use the PASELI service can pay playing fees using PASELI in "VIRTUAL COIN".

Please set the money-related settings. (Page 87)

5. Exit test mode

- 1 Select "GAME MODE" on the MAIN MENU screen.
- 2 Touch the ENTER panel. 3 The screen will switch to game mode and the game demo will start.

6. Close the door

1. Close the service door. 2. Turn the maintenance key counterclockwise and remove it.

7. Close the power supply unit cover.

Refer to page **39** and close the power supply unit cover.

• This completes "Installation 6: Initial startup settings."
Next, perform "Installation 7: Installing the Pop" (•Page **152**) .

Installation 7 Installing the pop



- Parts replacement, maintenance, and troubleshooting for this product must be performed by a store maintenance staff member or technician, or requested through the after-sales service center (fees apply).
- The pop should be installed with the adjuster in contact with the floor.

Materials to be set in this item

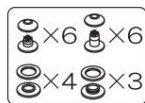
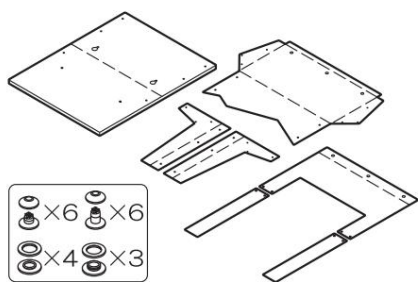

Pop set (instructions included)

Screw A



x4

Cross recessed truss head machine screw
(M6 x 15L)

Washer A



x4

Flat washer size 6 (D20 T1.6)

How to install

- Temporarily fasten the screws and flat washers.

Temporarily fasten screws A and washers A (top two places) to the fixing bracket. *At this time, leave some space to set the pop.

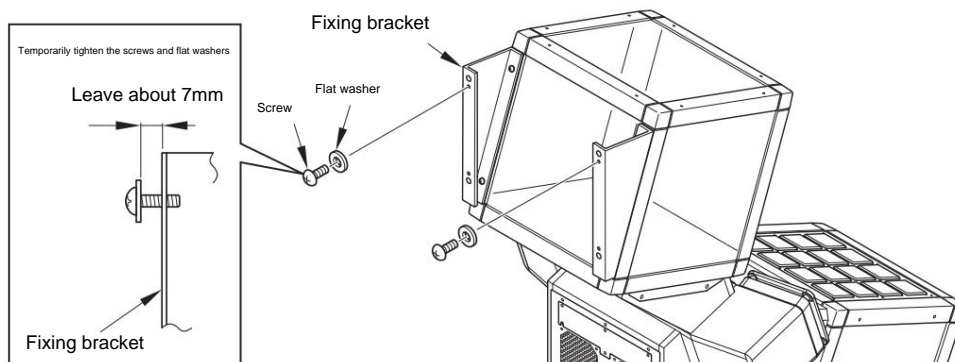

2. Install the pop

1. Assemble the POP by referring to the instructions that came with the POP.
2. Set the POP in place, aligning the upper hole position of the POP with the temporarily set screw position.

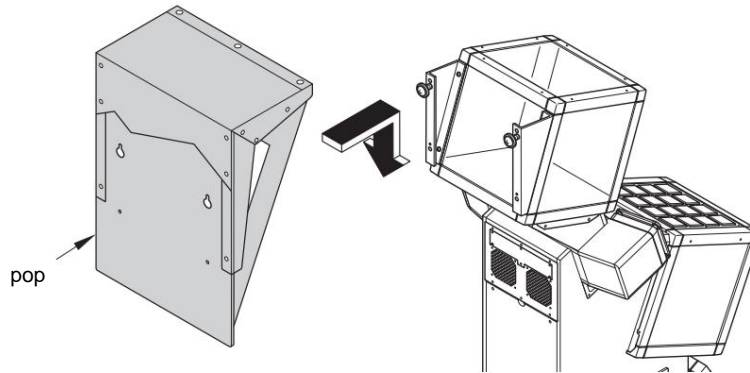

γ Regarding the position of the pop hole

1. Insert screw A and washer A into the hole in the pop

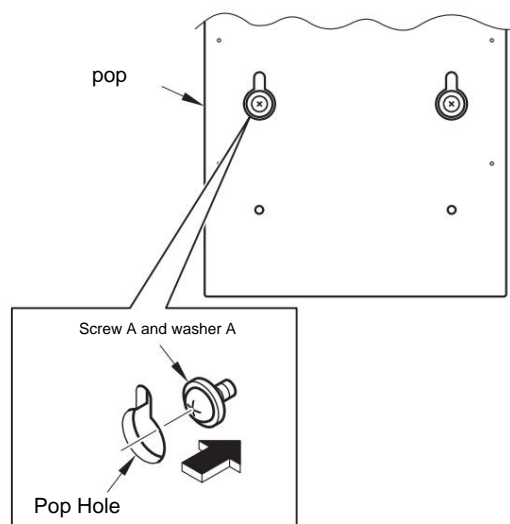

2. Slide the pop down and set it in place, then tighten screw A.

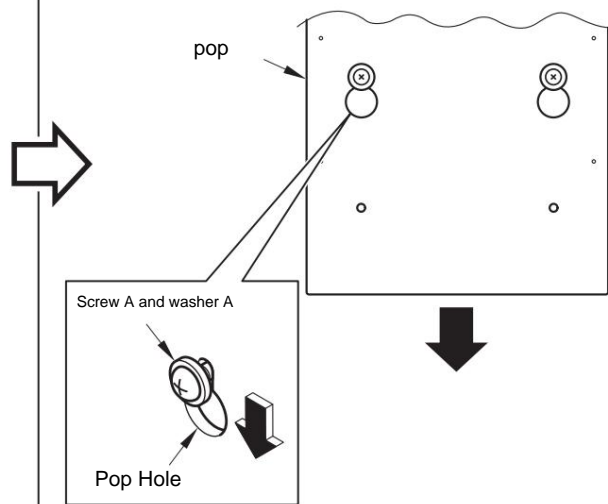

3 Fix the pop

1 Fix with screws A and washers A (2 places on the bottom).

2 Securely fix the screws A and washers A (2 places on the top) that were temporarily fixed.

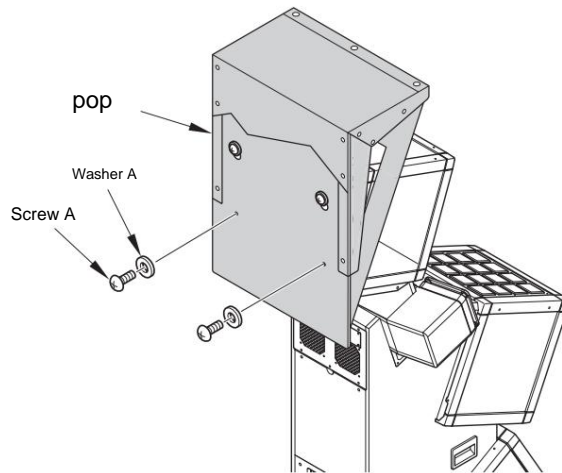

• Installation is now complete.

10.Maintenance

156 10 Maintenance

When relocating the coin counter

The coin counter is shipped with the coin door open to view it, but it can be moved to the service door.



- Before relocating the coin counter, be sure to turn off the main power switch and unplug the power cord from the outlet.
- After turning the power off, wait at least 10 seconds before turning it on again.

How to relocate



1 Turn off the power (Page 39)

- 1 Open the power supply unit cover on the back of the unit .
- 2 Turn off the main power switch and unplug the power cord from the outlet.

2. Take out the coin box

- 1 Open the coin door (page 42) .
- Take out the 2 coin boxes.

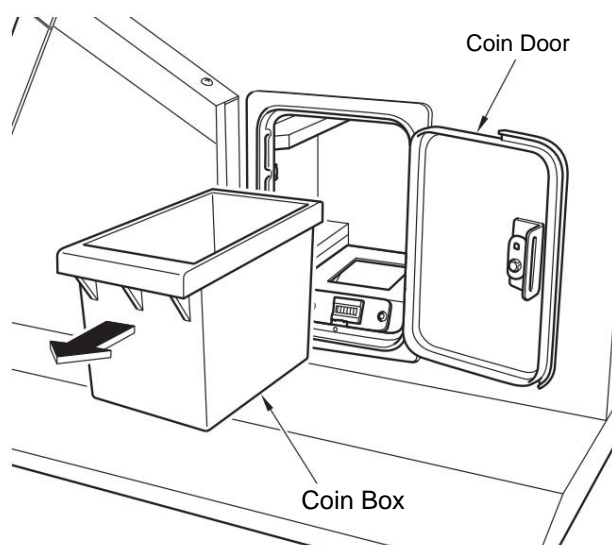

3 Remove the coin counter.

vinegar.

1. Remove the two screws. 2.

Pull out the coin counter and remove the connector. *The removed screws

will be used in step 7.

vinegar.

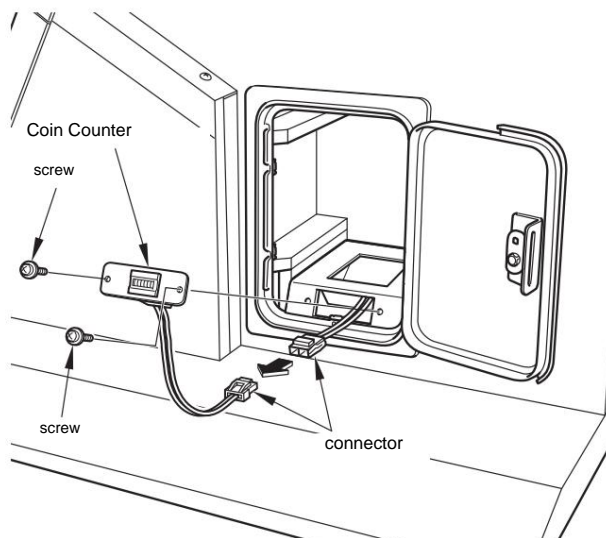

4. Open the service door

1 **Insert** the maintenance key and turn it to the right.

2 **Open** the service door.

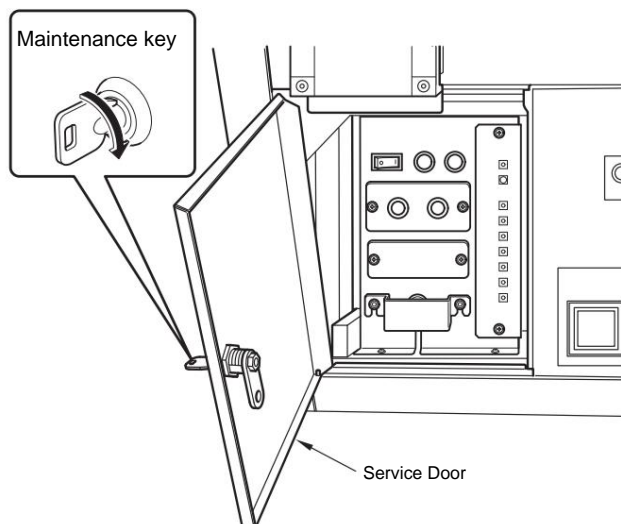

5 Remove the relocation cover

1. Remove the two screws shown in the illustration. 2. Remove the service panel cover.

3 **Remove** the clamp on the back of the cover and remove the connector.

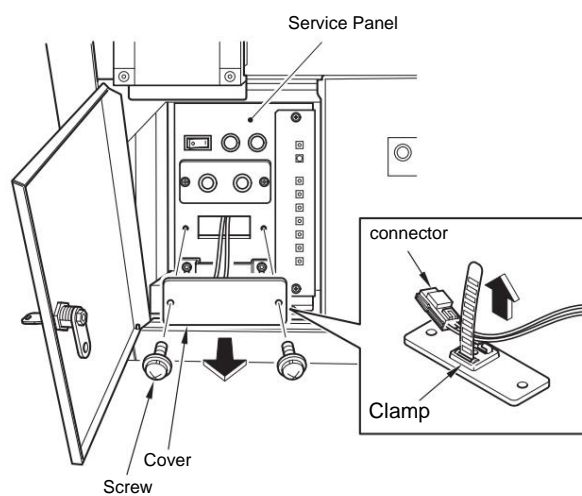

6 Install the coin counter

Can

1. Remove the coin counter you removed in step 3 .
2. Attach the connector to the service panel using the screws removed in step 5 .

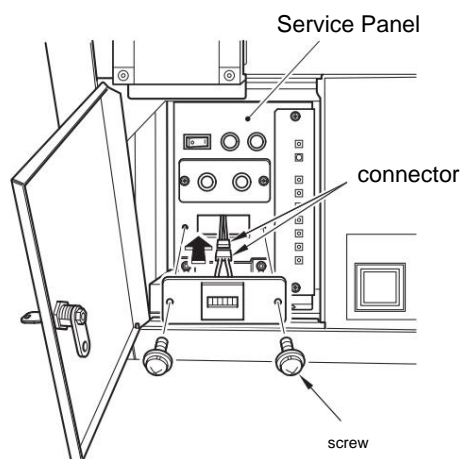

7 Attach the cover

- 1 Secure the connector with the clamp on the back of the cover that you removed in step 5.
- 2 Attach the cover to its original position on the coin counter using the screws removed in step 3.

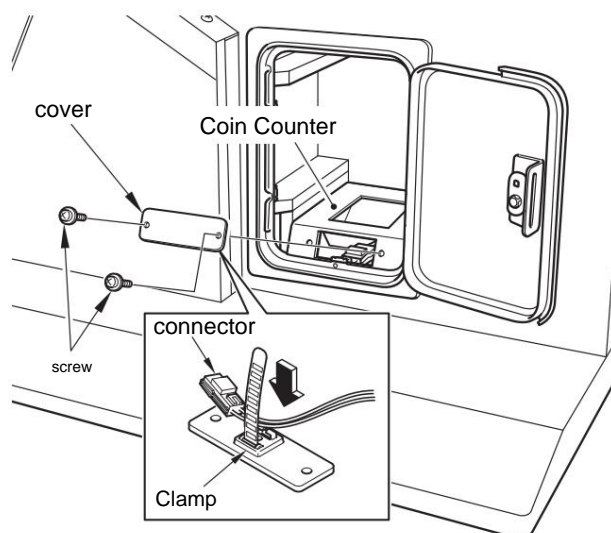

8. Put the coin box back in place

Set

1. Put the removed coin box back in its place. 2. Close and lock the coin door.

9. Close the service door

- 1 **Replace** the service door and close it.
2. Lock the door .

Coin selector replacement

How to replace



- Part replacement, maintenance, and troubleshooting for this product should be carried out by a store maintenance staff member or technician, or requested through the after-sales service center (fees apply).
- Before replacing the coin selector, be sure to turn off the main power switch and unplug the power cord from the outlet.
- After turning the power off, wait at least 10 seconds before turning it on again.
- When replacing parts or consumable parts, always use parts specified by our company. Never use or mix with other parts.
- Never disassemble, repair, set up, or modify any part not specified in this manual.



1 Turn off the power (Page 39)

- 1 Open the power supply unit cover on the back of the unit.
- 2 Turn off the main power switch and unplug the power cord from the outlet.

2 Open the service door

- 1 Unlock the service door (Page 40).
- 2 Open the service door.

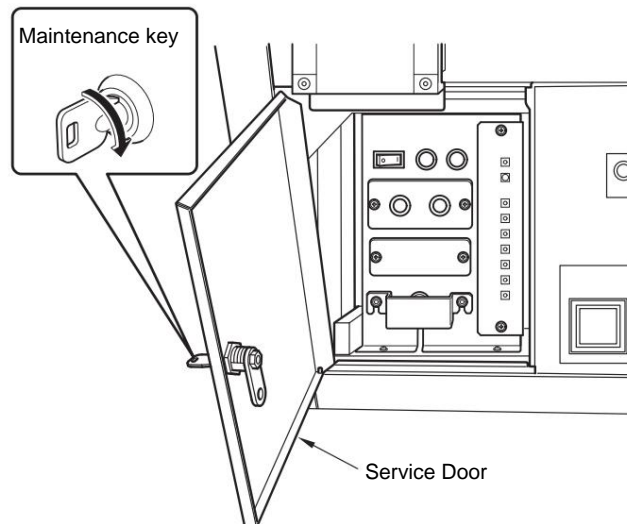

3 Unlock

Slide the lock release lever that secures the coin selector in the direction of the arrow to hook it onto the lock section.

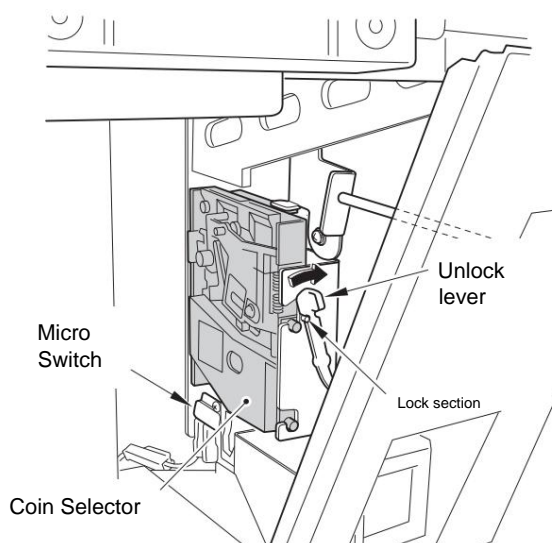

4 Remove the coin selector.

Slide the coin selector along the groove in the direction of the arrow to remove it.

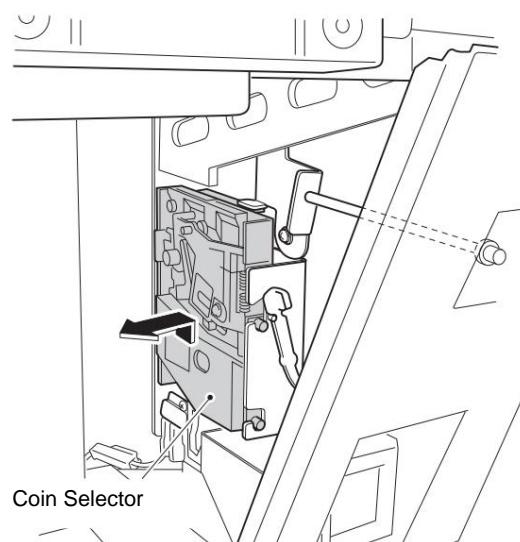

5 Replace the coin selector

1. Set the coin selector so that the two projections and the notches are aligned. At this time, turn the coin return lever linked to the coin return button as shown on the next page.
MEMO. 2 Return the lock release lever to its original position to lock the coin selector.

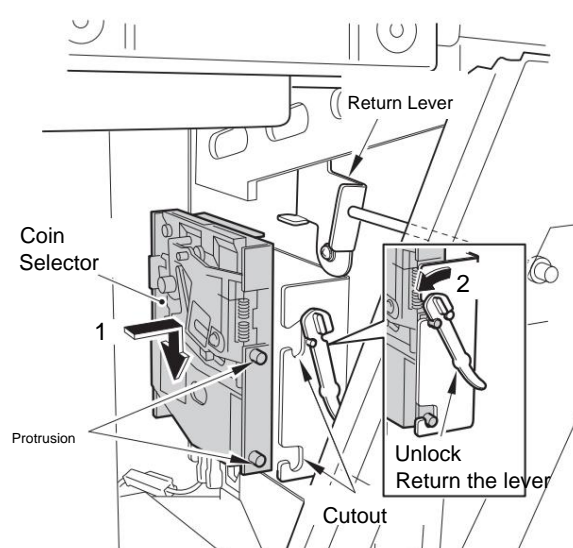

NOTE ÿ Before installing the coin selector, set the return lever as shown in the left figure.

stomach.

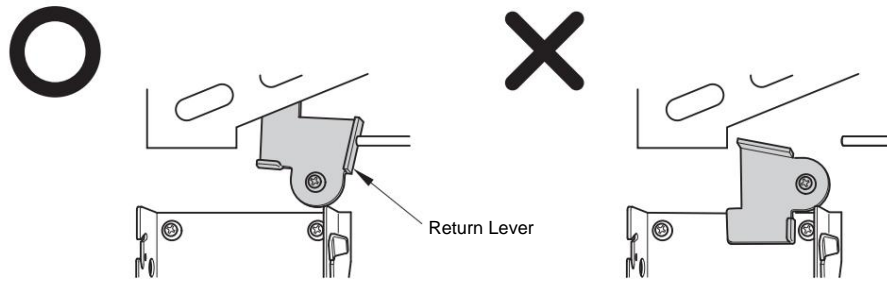

- ÿ After installation, make sure to return the lock release lever to its original position.
- ÿ Once the exchange is complete, press the coin return button to check the operation.

6 Turn on the power (ÿPage 39)

1. Connect the power plug to the outlet.
and turn on the main power switch.
- 2 Power supply unit cover on the back of the unit
Install the bracket.

7. Check the operation

- 1 **Open** the service door.
(ÿPage 40)
- 2 Press the test button to test
Start the mode (ÿPage 51) .
- 3 Check the coin count in "COIN MECH"
under "I/O CHECK >> INPUT
CHECK" in the **MAIN MENU** and in
"I/O CHECK >> OUTPUT CHECK".
Check the input.
(ÿPages 56 and 60)
- 4 After checking the operation, close the service door.
and lock it.

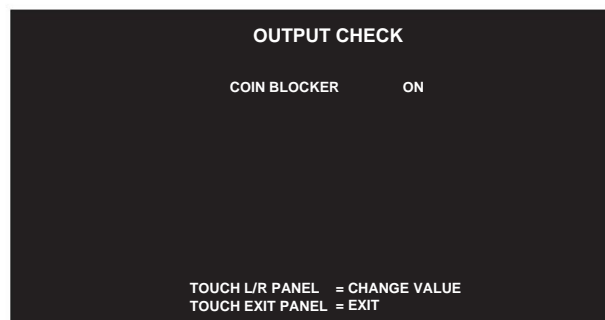
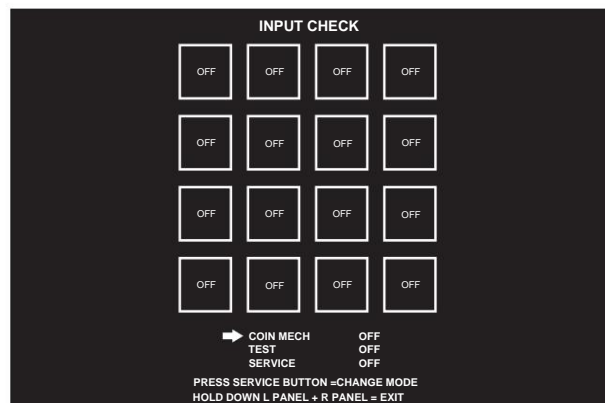

Rubber switch replacement



- Parts replacement, maintenance, and troubleshooting for this product must be performed by a store maintenance staff member or technician, or requested through the after-sales service center (fees apply).
- Always turn off the main power switch before replacing the rubber switch. • After turning the power off, wait at least 10 seconds before turning it on again. • When replacing parts or consumable parts, always use parts specified by our company. Never use or mix other parts.
- Never disassemble, repair, set up, or modify any part not specified in this manual.

- If the rubber switch is damaged, replace it immediately. • Since you will be removing many screws, we recommend that you keep several small boxes ready to avoid losing them.

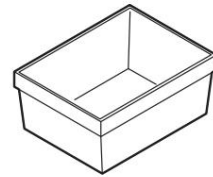

How to remove



1 Turn off the power (Page 39)

- 1 Open the power supply unit cover on the back of the unit.
- 2 Turn off the main power switch and unplug the power cord from the outlet.

2 Remove the left and right covers.

- 1 Using a hexagonal wrench (2 mm across flats), remove the 12 long screws from the left and right covers.

*Size and shape of the removed screws (12 pieces)

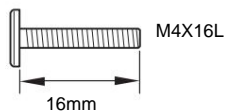

2 Remove the cover.

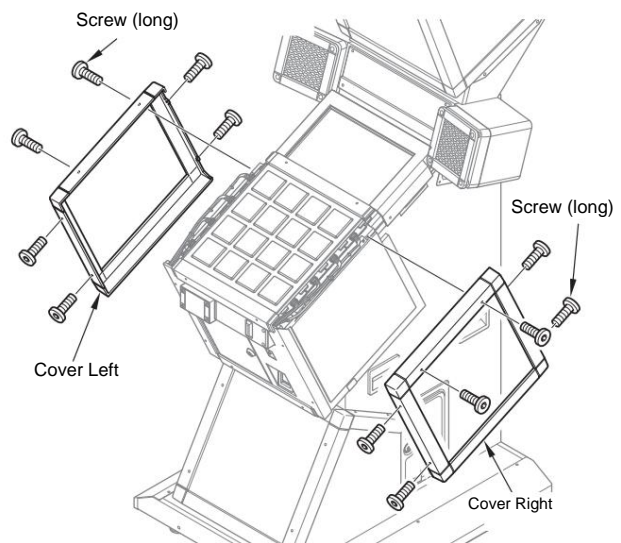

3 Remove the top and bottom covers

1. Using a hexagonal wrench (2 mm across flats), remove the four short screws on the top and bottom covers. *

Check the size and shape of the four removed screws.

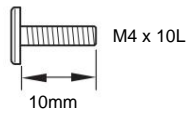

2 Remove the cover.

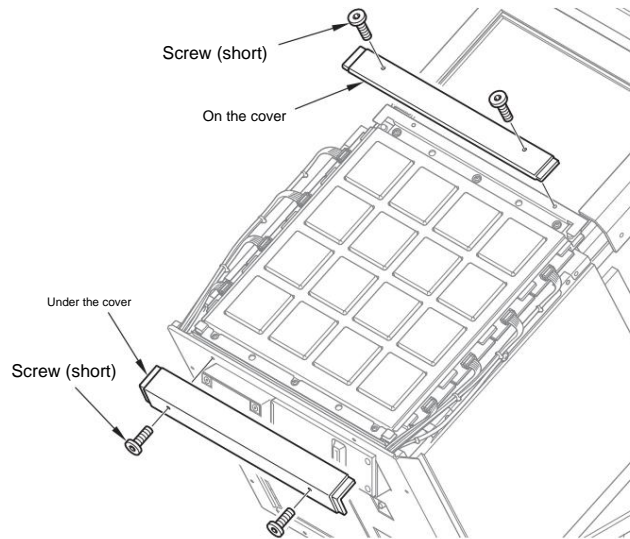

4. Unplug the connector

Disconnect the connectors (8 places) shown in the illustration that are connected to the panel unit.

* When unplugging the connector, hold the connector and pull it out slowly.

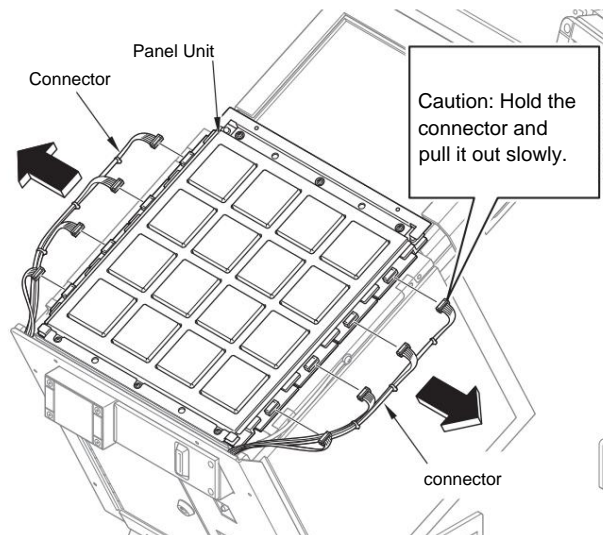

5 Remove the top and bottom screws

Remove the six screws from the top and bottom that secure the panel unit.

*Size and shape of the removed screws (6 pieces)

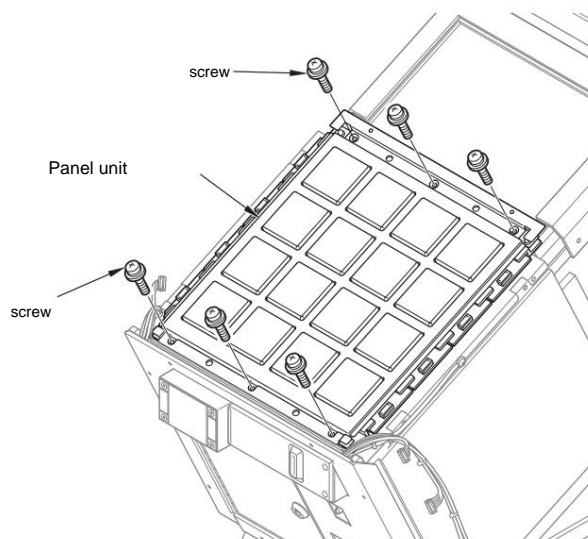
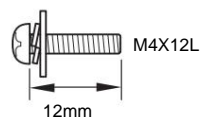

6 Remove the panel unit

Gently lift the panel unit and remove it.

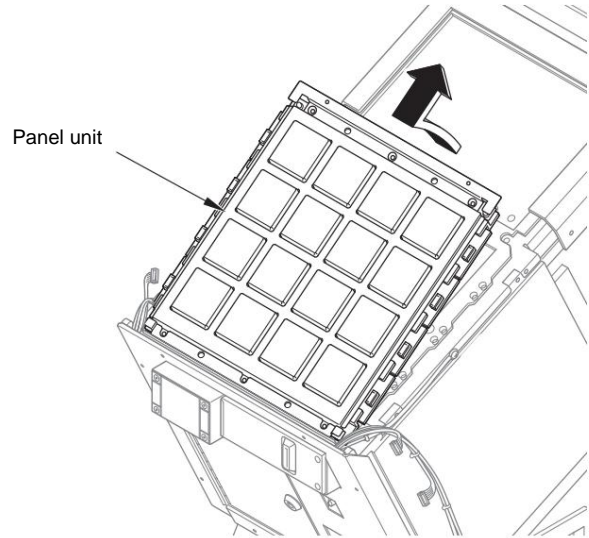

MEMO Place the panel unit on a soft cloth laid on a flat surface before working on it.

7 Remove the flange nuts

- 1 Place the removed panel unit on a flat surface with the back side facing up.
- 2 Use a box wrench (7 mm across flats) to remove the flange nuts (13 locations).

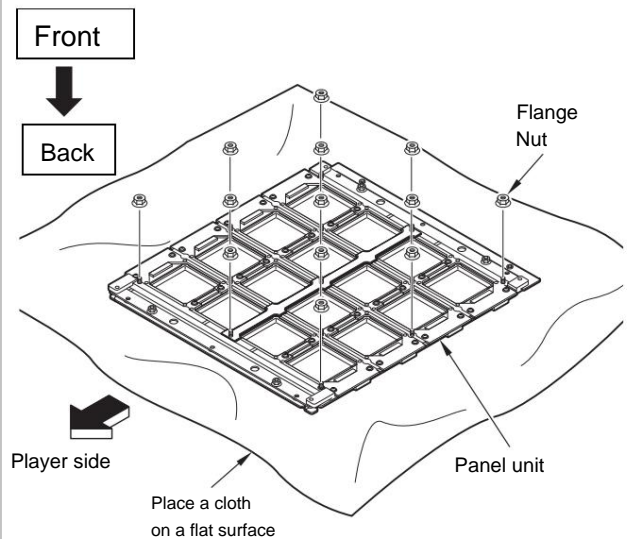

Working on an uneven surface may cause the rubber switch to become misaligned.

8 Remove the holding plate

Remove the retaining plate shown in the illustration.

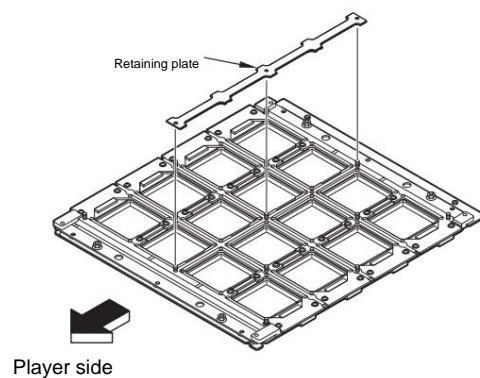

9 Remove the upper and lower brackets.

vinegar.

1 Use a box wrench (7 mm across flats) to remove the flange nuts (4 locations).

2 Remove the top and bottom brackets .

vinegar.

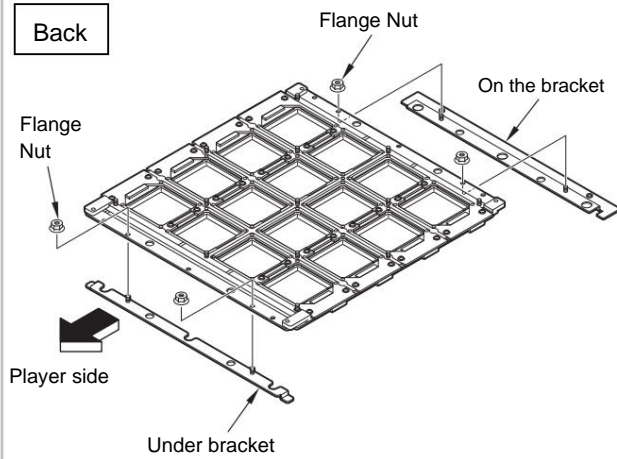
**10 Remove the panel cover**

1 Turn the panel unit face up.

vinegar.

2 Remove the four screws. *The size and shape of the four removed screws

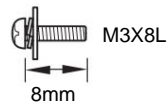

3 Remove the panel cover.

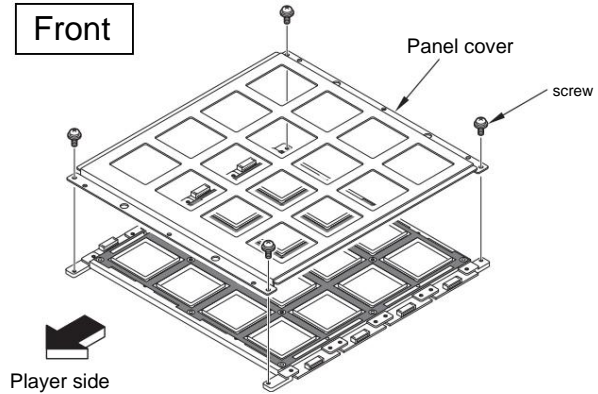
**11 Remove film B**

Remove film B as shown in the illustration.

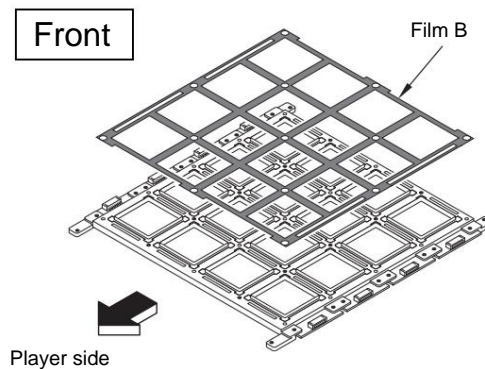

12 Remove the panel

Remove all 16.

*The rubber switch may stick to the panel when it is removed.

Front

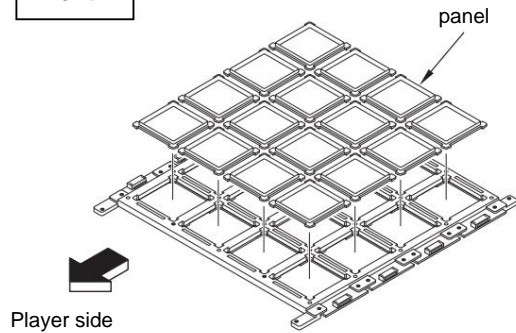

13 Remove the rubber switch

Pinch the protrusions on the rubber switches at the four corners of the board to remove them.

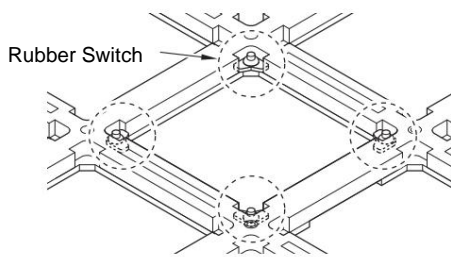

Front

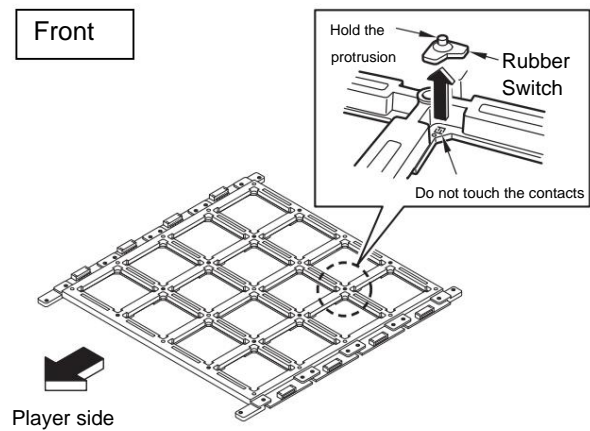

Caution (If the rubber switch is damaged, replace it immediately!)

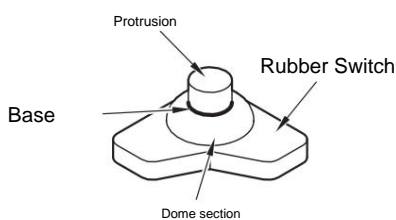

If the protrusion of the rubber switch is sunken into the dome and cannot be returned, or if there is a crack at the base, the rubber switch is damaged and should be replaced immediately.

If you continue to play with one of the four rubber switches broken, the lifespan of the remaining three rubber switches will be significantly reduced, resulting in premature breakage.

*We recommend replacing all the rubber switches at the same time.
There are four rubber switches per panel (total of 64).

NOTE When removing the rubber switch, do not touch the contacts.

If any of these substances adhere to the product, it may not function properly.

14 Remove dirt from the contacts

Use a cotton swab to clean the contacts on the board.

*To clean, place your hand on the back of the board and rub the contacts firmly with a cotton swab to remove any dirt.

Front

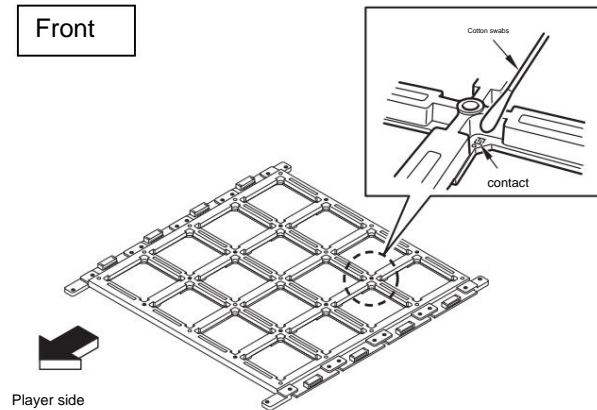

MEMO ÿ When cleaning the contacts, do not use organic solvents such as thinner, benzene, or alcohol, or detergents containing abrasives, as these may cause deformation or damage to the parts. Be particularly careful not to let these come into contact with acrylic parts such as panels.

15 Install the rubber switch

Hold the protrusions of the new rubber switch and reinstall it in place.

* When installing the rubber switch, do not touch the contacts. If oils from your hands get on the contacts, they may not function properly.

View from behind



Do not touch the contacts

Front

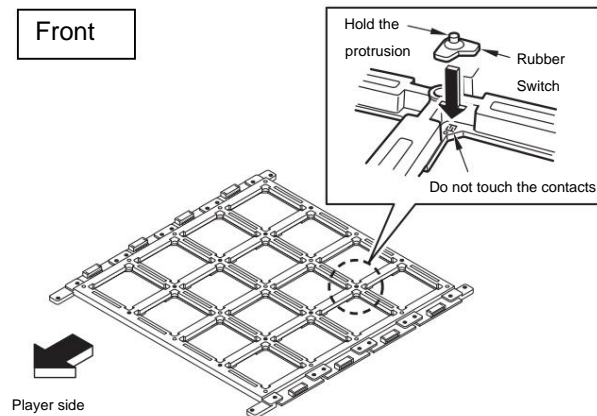

MEMO ÿ We recommend replacing all the rubber switches at the same time.

*There are 4 rubber switches per panel (64 in total).

How to install

When installing the panel unit during maintenance or other such procedures, be sure to use the original screws that were removed.
Please use the
When replacing the rubber switch, be careful not to install the "holding plate" in the wrong direction.
Please.

1 Place one panel

Put the 16 panels back in place.

Front

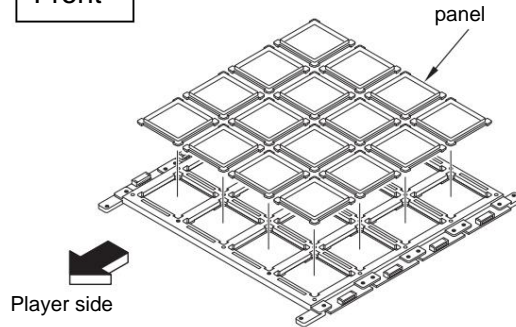

MEMO When installing the rubber switch, be careful not to install the "holding plate" in the wrong direction.

2 Place film B

Check that the rubber switch is not misaligned, then place film B.

Front

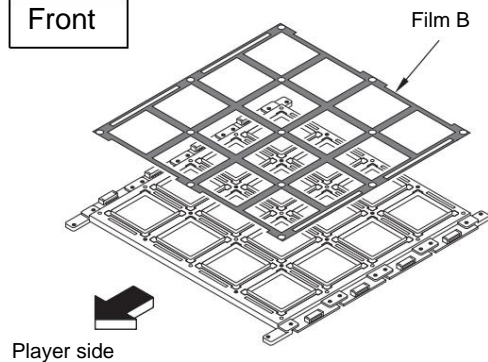

NOTE The glossy side of Film B is the front. Be careful of the orientation when installing.



3 Attach the panel cover

1. Replace the panel cover. 2. Secure the panel cover with the screws.

*Size of mounting screws (4 pieces)

and shape



Front

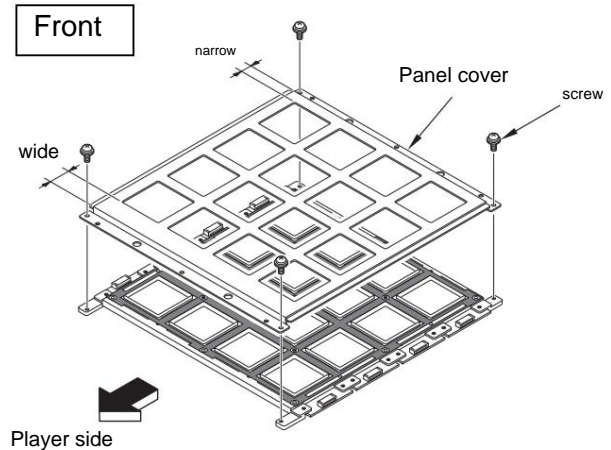

4 Turn the panel unit over

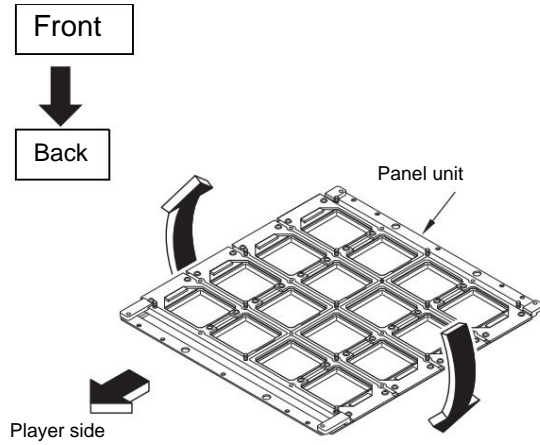

MEMO ÿ Be sure to attach the panel cover in step 3 before turning it over.

5 Attach the upper and lower brackets.

Can

1 Place the upper and lower brackets in their original positions.

*There are upper and lower brackets.

Tighten the flange nuts (four locations) using a **2-way** box wrench (7 mm across flats).

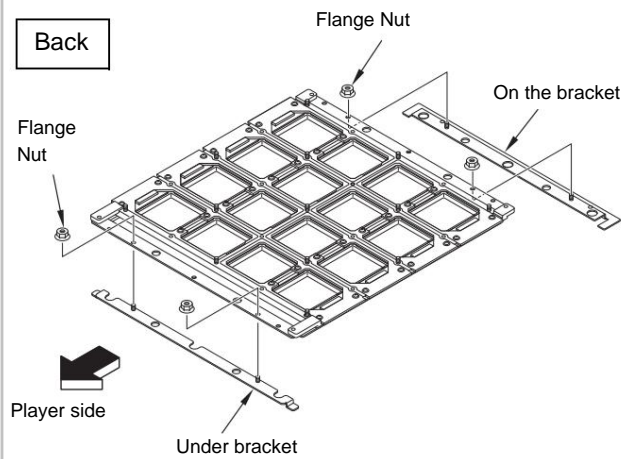

MEMO ÿ Make sure the rubber switch is installed correctly.

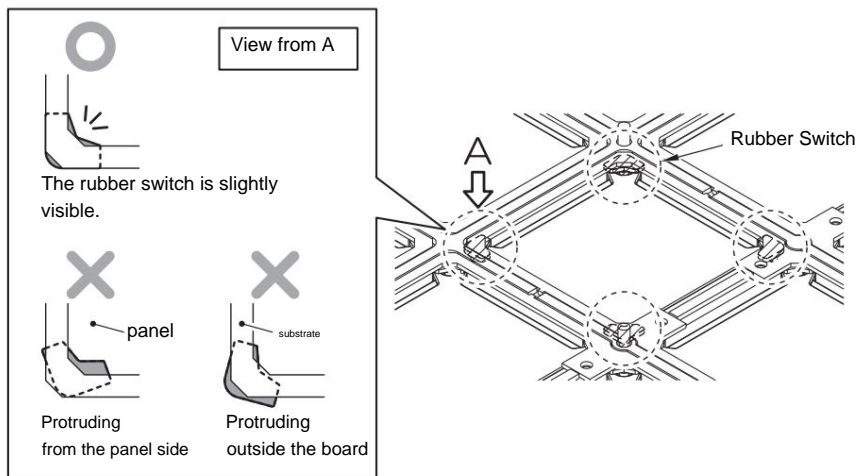

6 Attach the holding plate

Attach the retainer plate in the position shown in the illustration.

*The silver surface of the pressure plate is visible.
Also, install it perpendicular to the metal part as shown in the figure.

Back

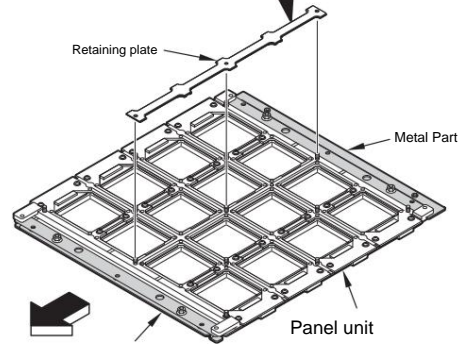
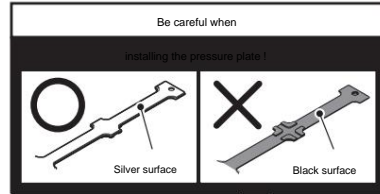

Metal part on the player side

When installing the pressure plate, pay attention not only to the front and back, but also to the vertical and horizontal installation direction.

If the retaining plate is installed in the wrong direction, the life of the rubber switch will be significantly shortened, resulting in early damage.

Caution (Be careful not to install the holding plate in the wrong direction!)

* Mounting direction of the pressure plate

Correct) Vertical to the player

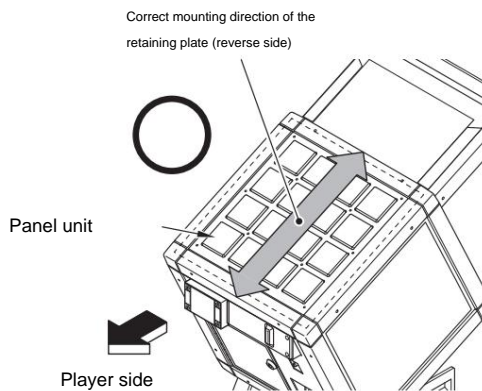

Incorrect) Sideways to the player

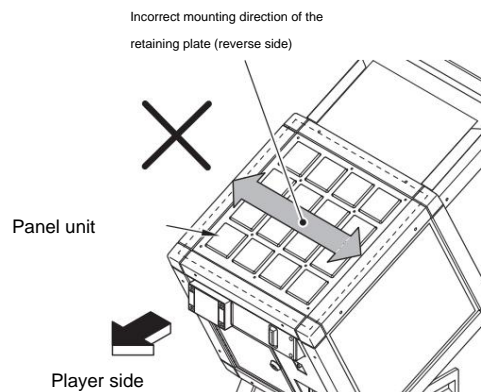

• The illustration shows the panel unit attached to the main unit.

7. Temporarily fasten the holding plate

Temporarily secure the retainer plate with flange nuts (3 places).

*The rubber switch will be pushed out of place by the panel, so while lifting the panel unit, temporarily tighten the flange nut with your fingers.

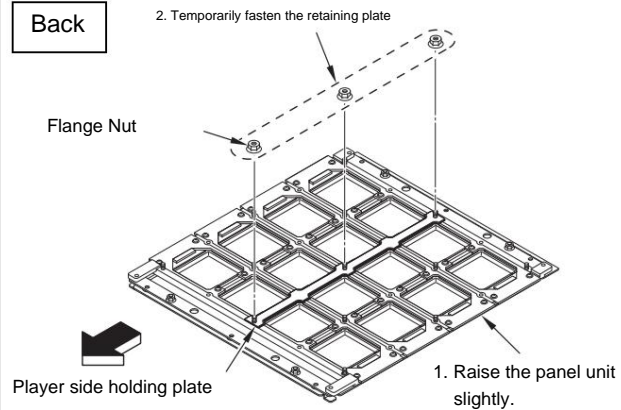

MEMO ◡ Please check again to make sure the rubber switch is installed correctly.

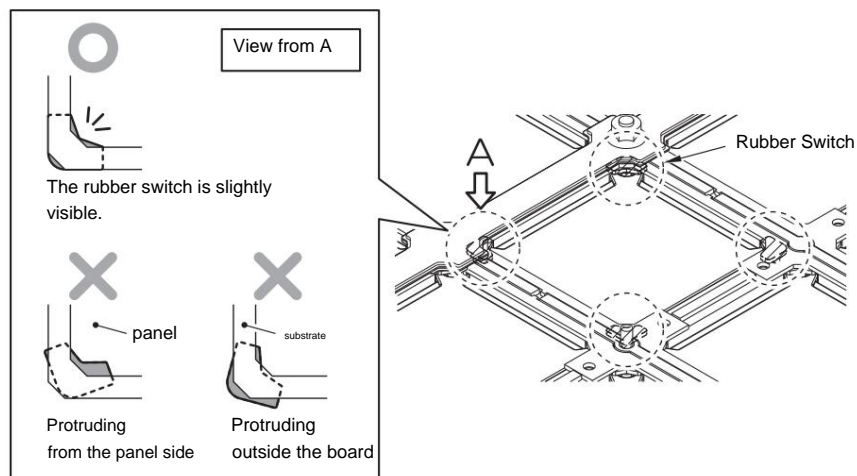

8 Install the flange nuts

R

1 Next, temporarily fasten the remaining 10 places with flange nuts. 2 Use a box wrench (7 mm across flats) to tighten the flange nuts (13 places).

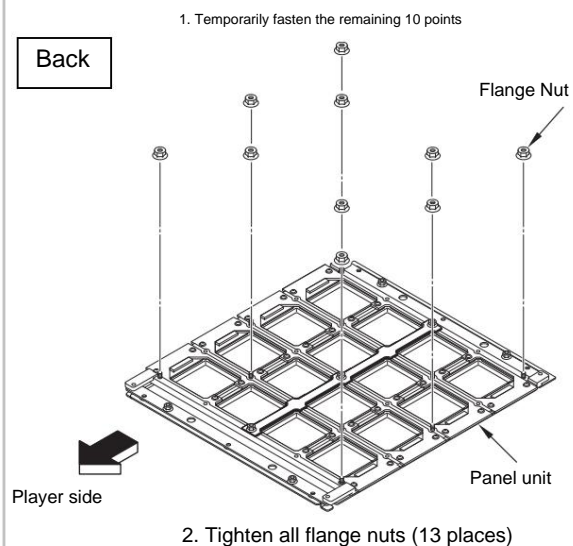

9. Install the panel unit

1 Gently insert the panel unit from the bottom of the main unit. * Be careful not to let film A slip out of place. 2 Secure the panel unit in place with the top and bottom screws removed in step 5 of "Removal" (ýpage 163) .

vinegar.

Caution (Be sure to use the specified screws!)

When installing the panel unit, be careful not to use the wrong length screws.

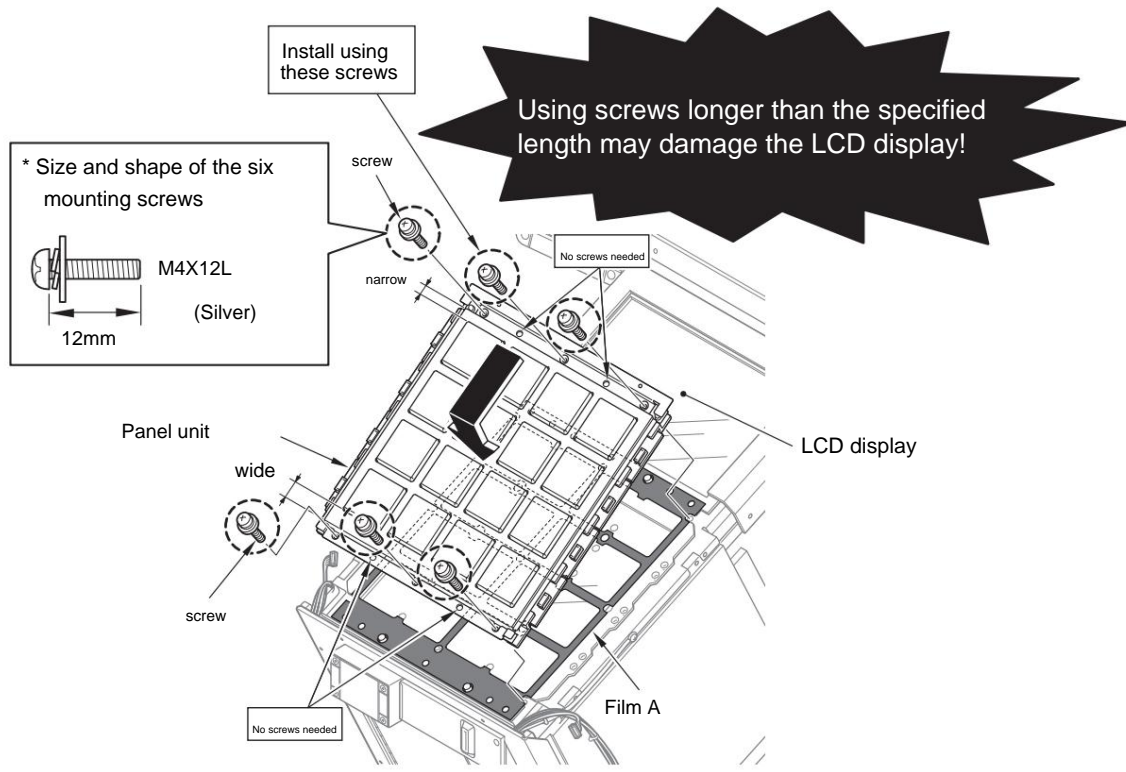

* Do not use the following screws when removing the left and right covers to attach the panel unit.

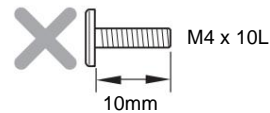
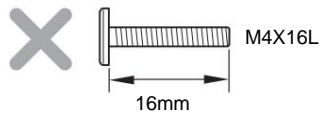

NOTE ý The matte side of Film A is the front. Be careful of the orientation when installing.

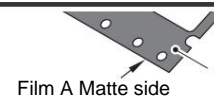

10 Connect the connector

Reconnect the connector that you removed in step 4 on page 163 to its original position.

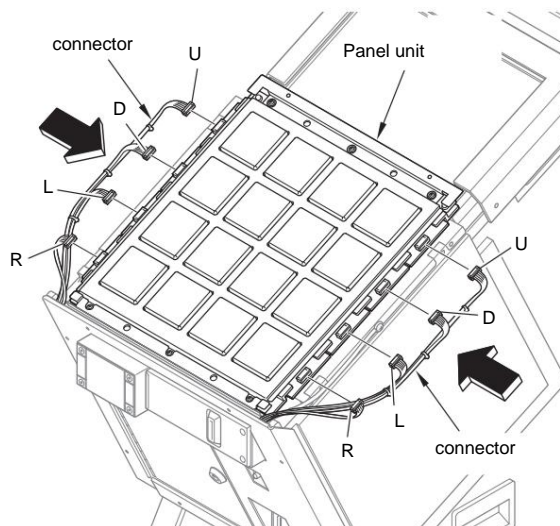

11 Attach the top and bottom covers

1 Reinstall the top and bottom covers that you removed in step 3 on page 163.

Fix it with 2 short screws.

*Size of the screws (4 pieces) to be used

and shape

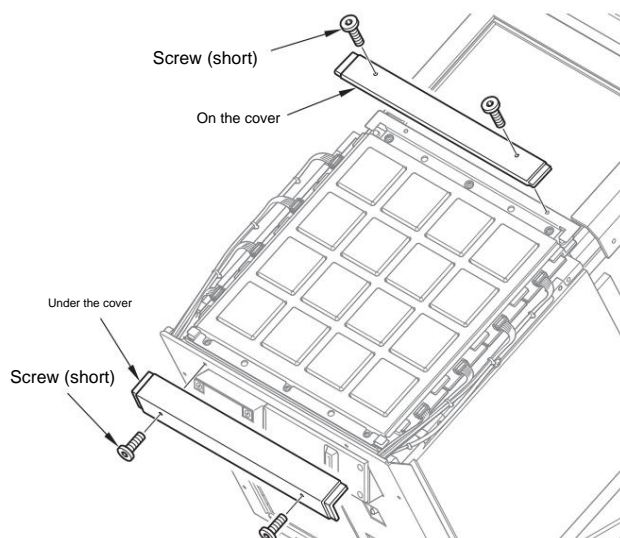
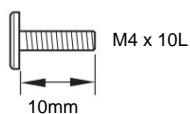

12 Attach the left and right covers

1 Reinstall the left and right covers that you removed in step 2 on page 162.

Secure with 2 long screws.

*The cover is available for right and left.

Size and shape of mounting screws (12 pieces)

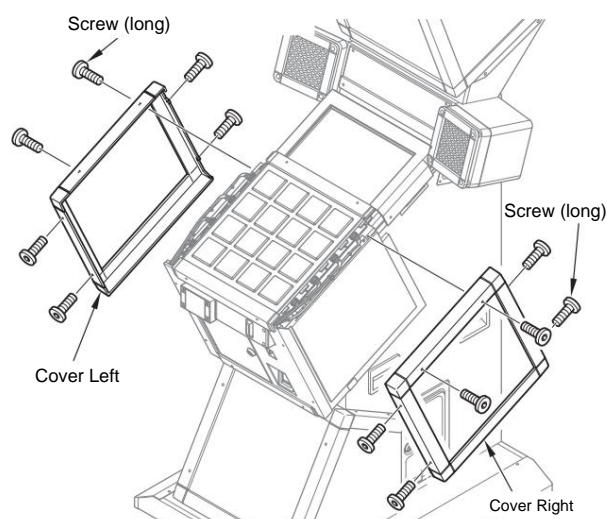
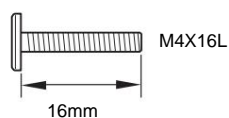

MEMO ÿ Be careful not to pinch the wire harness.

13 Turning the power on (ħPage 39)

1. Connect the power plug to the outlet.
and turn on the main power switch.
- 2 Power supply unit cover on the rear of the unit
Install the bracket.

14 Check the operation

- 1 Open the service door. (ħ Page 40) 2 Press
the test button to perform a test.
Start the mode (ħpage 51) .
- 3 In the MAIN MENU, go to "I/O CHECK
>> INPUT CHECK" and select "ħ".
The input state of all panels
Check it out. (ħPage 56 , Page 57)
- 4 After checking the operation, close the service door.
and lock it.

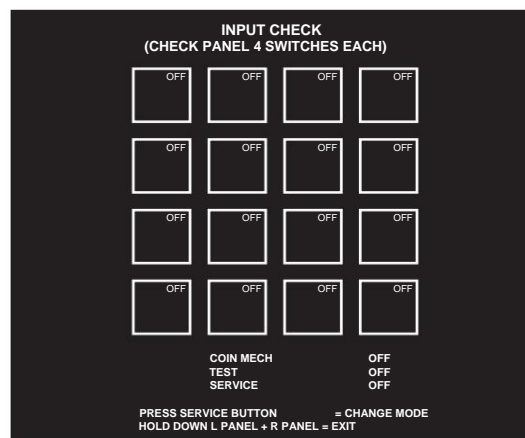

Replacing the hard disk unit



• Parts replacement, maintenance, and troubleshooting for this product must be performed by a store maintenance staff member or technician, or requested through the after-sales service center (fees apply).
 • Before replacing the hard disk unit, be sure to turn off the main power switch and unplug the product from the outlet.
 • After turning the power off, unplug the power cord before turning it on again.
 • When replacing the hard disk unit, wear an earthing strap to prevent static electricity.
 • Do not work on carpets or other surfaces.
 • Follow the precautions for handling the hard disk unit.

(Page 14)
• Make sure the hard disk unit is securely installed. Turning on the power when the hard disk unit is not properly installed may result in an error or damage to the hard disk unit.
 • Do not get the hard disk unit wet or touch the terminals.

If you need to replace the hard disk unit, please follow the procedure below. When you replace the hard disk unit, the values set in the test mode you have been using cannot be carried over. If you intend to use the same settings as before, we recommend that you record (make a note of) the current settings before replacing the hard disk unit.

• Identification labels: The PCB

unit and hard disk case (hard disk unit) of this product have a different shape than the units before the Ubeat Knit Append. Identification labels to distinguish the shape are affixed in the positions shown in the illustration, so if you have multiple units, please be careful not to make a mistake when installing.

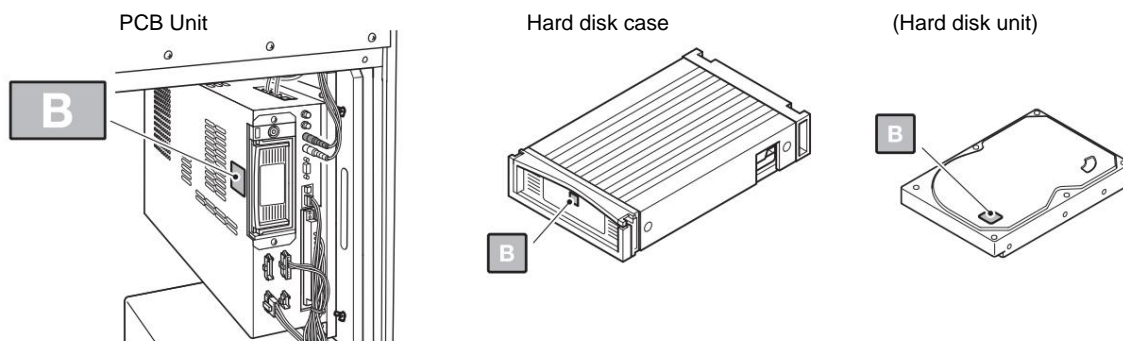

How to remove



- 1 Turn off the power (**Page 39**)
 - 1 Open the power supply unit cover on the back of the unit .
- 2 Turn off the main power switch and unplug the power cord from the outlet.

2 Remove the rear door

Remove the two screws shown in the illustration and then remove the rear door from the main unit.

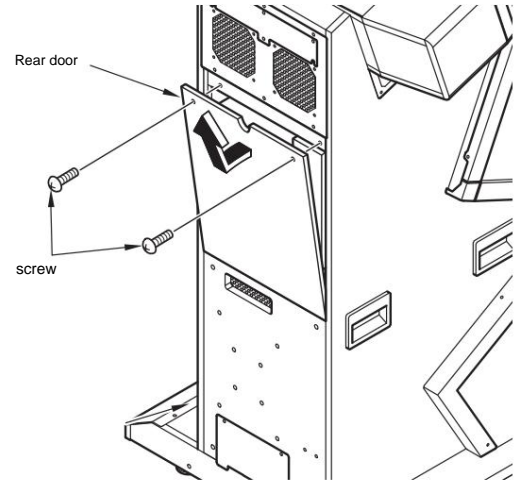

3 Wear the earth band

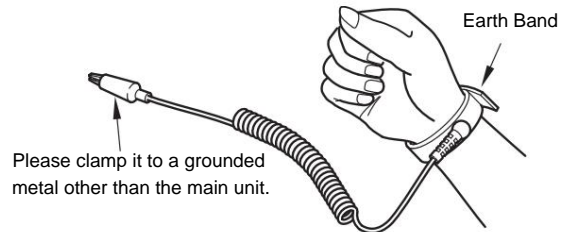

4 Hard Disk Unit

Remove

1 Insert the hard disk drive key provided with the PCB unit and turn it counterclockwise to set it in the free state.

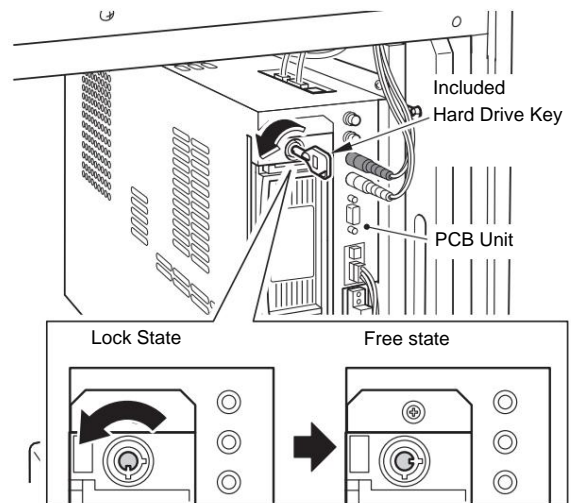

2. Remove the hard disk unit case by holding it by the handle.

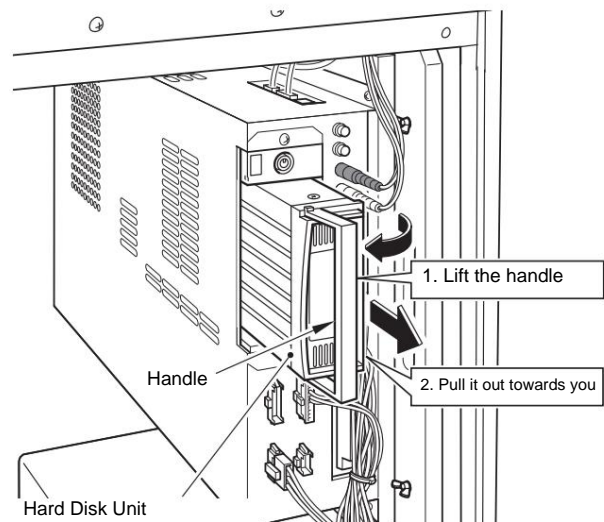

5 Remove the cover

Remove the cover of the removed case by removing the four screws shown in the figure.

*The size and shape of the four removed screws are



M3X7L

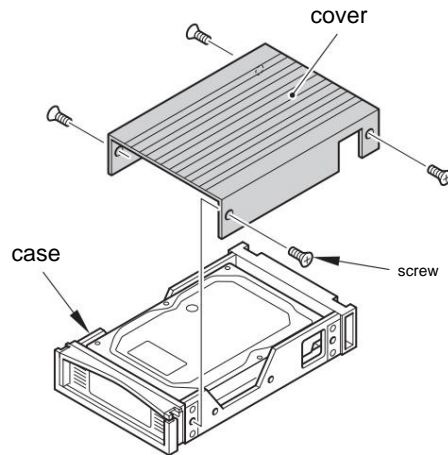

MEMO Be careful not to lose the screws you remove.

6 Fix the hard disk unit

Remove the screws that

Remove the four screws that secure the hard disk. *The size and shape of the four screws you removed

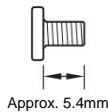

#6-32 x 1/4

Approx. 5.4mm

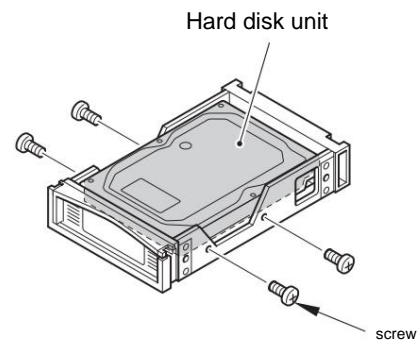

MEMO Be careful not to lose the screws you remove.

7. Remove the hard disk

Slide the hard disk unit out as shown in the figure to remove it.

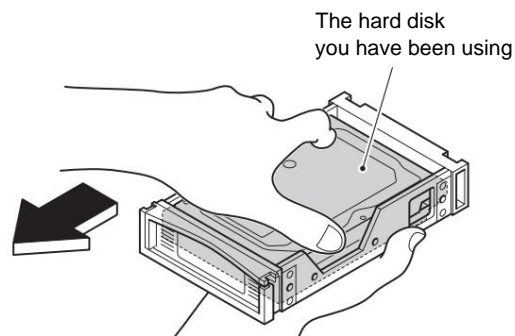

Be sure to slide it horizontally to avoid damaging the connector.

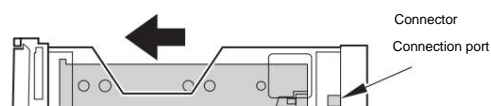

MEMO Be careful not to drop the hard disk itself.

How to install



When installing the hard disk unit, be sure to use the original screws that you removed.

1 New hard disk unit Attaching

Securely connect the new hard disk unit by reversing step 7 on page 177 .

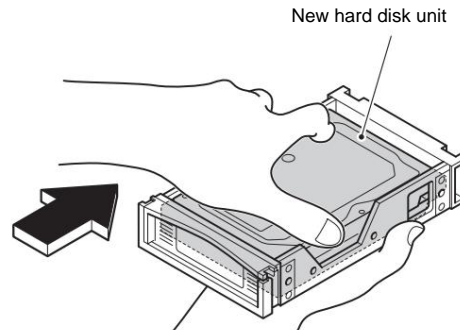

Connect the connector, align the screw holes, and be sure to secure it with screws.

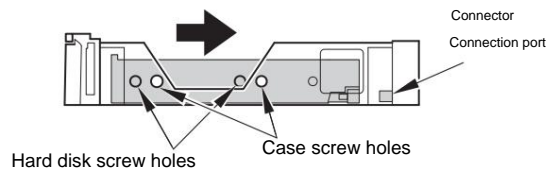

2 Screw the hard disk unit Fix it with

Secure the hard disk body with the screws removed in step 6 on page 177 .

*** Make sure to securely fasten the hard disk body and case with the four screws.**

*Size of mounting screws (4 pieces)

and shape

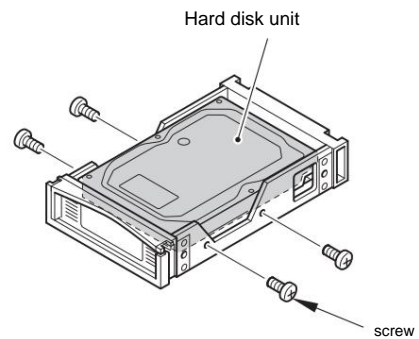
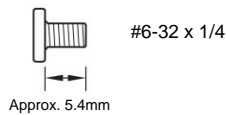

Be careful not to forget to tighten the screws

***If the screws are not tightened, the hard disk may malfunction.**

3 Attach the cover

Attach the cover back to its original position using the screws removed in step 5 on page 177. *The size of the

screws (4 pieces) to be used

and shape

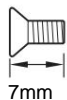

M3X7L

7mm

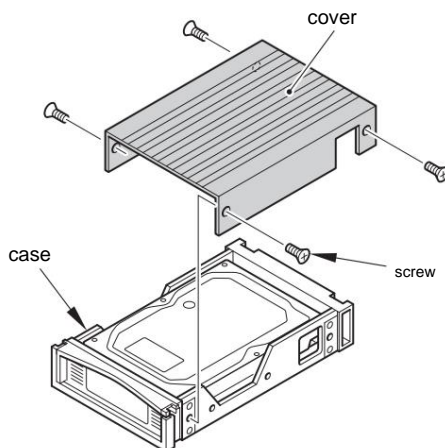

4 Hard Disk Unit Set

1 Return the case handle to its original position.

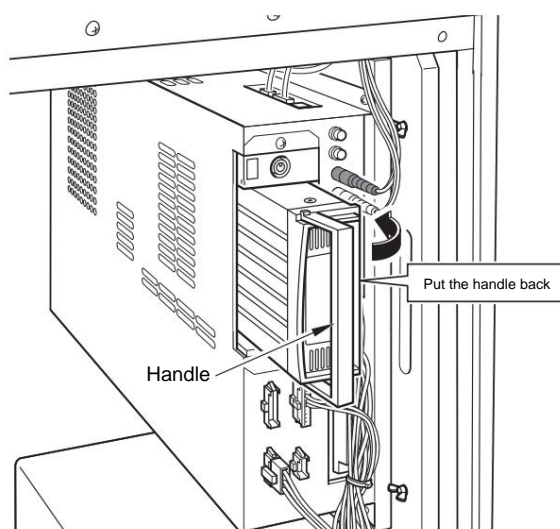

2 Place the hard disk unit case on the PCB unit, making sure to push the case all the way in.

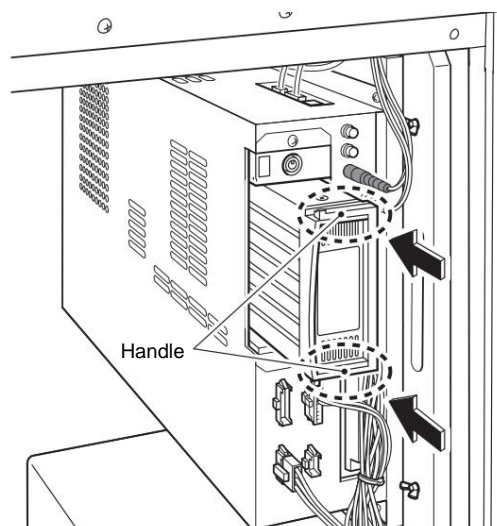

MEMO ÿ If the handle is raised, the case cannot be set securely into the PCB unit.

ÿ When setting the case, press the part of the handle shown in the figure. Be careful not to press the center of the case.



ÿ Make sure to push the case all the way in.

If it is not pushed all the way in, the connector inside the PCB unit will not connect and it will not function properly.

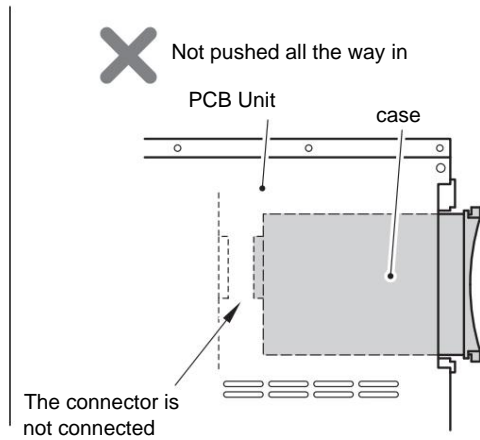
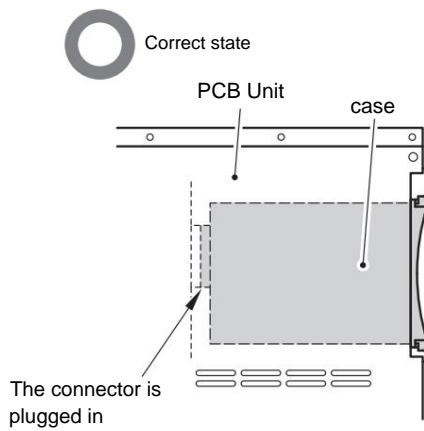

5. Lock it up

Insert the hard disk drive key and turn it to the right to ensure it is locked.

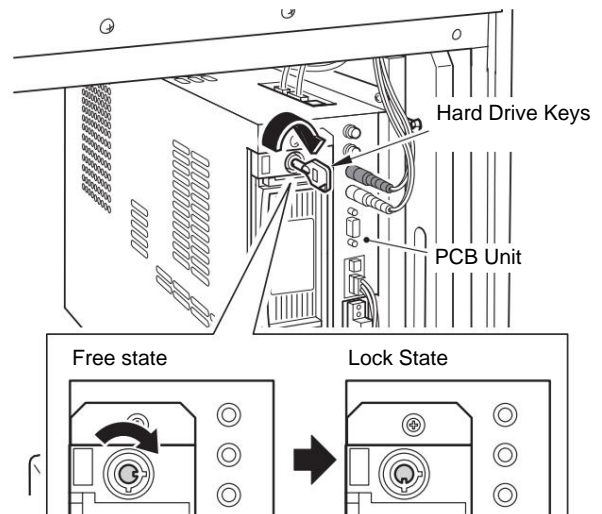

ÿ When locked, the hard disk drive is powered on.

In the free state, the power will not be turned on and the hard disk drive will not operate. ÿ When locking the case, make sure that the case is pushed all the way in before doing so.

6 Close the rear door.

Secure the rear door with the screws.

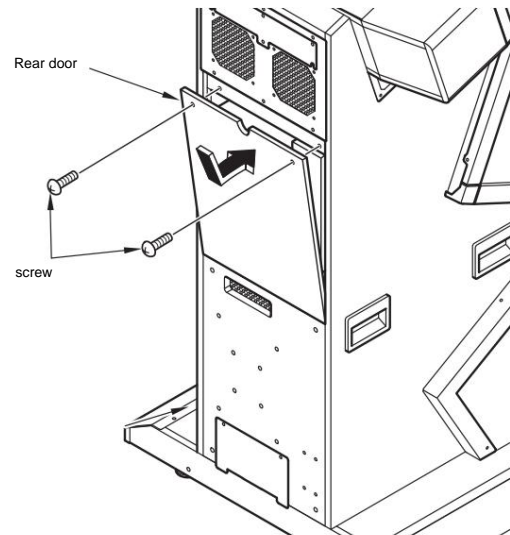

7 Turn on the power (ÿPage 39)

1. Plug the power cord into a power outlet and turn on the main power switch.
2. Attach the power supply unit cover to the back of the unit.

ÿ This completes the "Replacing the Hard Disk Unit".

Next, configure the various settings in "6 Game Settings". (ÿPage 49)

Circuit protector returns

When an overcurrent or short circuit occurs, the circuit protector automatically operates to protect the electrical circuits of this product. To restore power, turn off the main power switch, unplug the power cord from the outlet, remove the cause of the problem, and then press the circuit protector button.

How to return



• Parts replacement, maintenance, and troubleshooting for this product should be performed by a store maintenance staff member or technician, or requested through the after-sales service center (fees apply). • Before resetting the circuit protector, be sure to turn off the main power switch and unplug the power cord from the

• After turning the power off, wait for 10 seconds or more before turning it on again. • If the power turns off immediately after resetting the circuit protector, turn off the main power switch, unplug the power cord from the outlet, and contact our after-sales service center. • Do not allow anyone other than a technician to open the rear door of the main unit. • After opening the rear door, take great care not to touch surrounding devices carelessly. • After opening the rear door, be sure to turn off the main power switch of the power supply unit and unplug the power cord from the outlet. • If the abnormal condition continues or the unit does not operate normally, immediately turn off the main power switch, unplug the power cord from the outlet, and contact our after-sales service center.



1 Turn off the power (Page 39)

- 1 Open the power supply unit cover on the back of the unit.
- 2 Turn off the main power switch and unplug the power cord from the outlet.

2. Eliminate the cause

*If you are unsure of how to handle the problem, do not try to do it yourself but contact the after-sales service desk.

3 Circuit Protector

Press the button

Press the circuit protector button on the power supply unit.

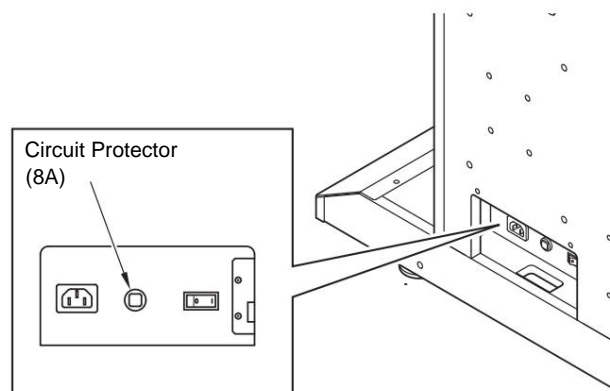

11 Troubleshooting

184 11 Troubleshooting When the device

does not operate normally



- If the same error message appears even after you have taken the corrective action, or if a message not mentioned in this manual appears, immediately turn off the main power switch, unplug the power cord from the outlet, and contact the after-sales service center. • If you want to turn the power back on after turning it off, wait at least 10 seconds before doing so. • If you are unsure of how to solve the problem, do not try to do it yourself, but contact the after-sales service center. Inquire
- If a malfunction or breakdown is detected, immediately turn off the main power switch, unplug the power cord from the outlet, and contact the after-sales service center.

If the unit does not operate normally even after you turn on the main power switch, try the following solutions: If an error code or message appears on the screen, refer to the "List of Error Codes and Messages."

Symptoms	Possible Cause	handle
If any of the following symptoms persist on the monitor screen for 90 seconds or more after the power is turned on: - The screen is distorted - "No Cable" is displayed on the screen - Nothing is displayed on the screen (black screen) - "DISK BOOT FAILURE, INSERT SYSTEM DISK AND PRESS ENTER" is displayed on the screen	<ul style="list-style-type: none"> • The hard disk drive case is not pushed all the way in or the hard disk drive is not locked. 	<ul style="list-style-type: none"> • Make sure to push the hard disk drive case all the way in and lock it using the hard disk drive key. (•Page 180)
	<ul style="list-style-type: none"> • The wire harness (connector) connected to the PCB unit is loose. 	<ul style="list-style-type: none"> • Wire harness (connector) Connect the power adapter (USB 3.0 or later) correctly (•Pages 121 to 122).
	<ul style="list-style-type: none"> • There was some abnormality in the PCB unit. 	<ul style="list-style-type: none"> • Turn off the main power switch, wait for 10 seconds or more, then turn it back on. • If the problem persists even after taking the above measures, please contact our after-sales service desk.

Symptoms	Possible Cause	handle
Nothing appears on the screen and the lights don't light up.	<ul style="list-style-type: none"> • The power is not turned on. <ul style="list-style-type: none"> •Main power switch •Sub power switch •Store breaker 	<ul style="list-style-type: none"> • Turn on the power switch. (•Pages 39 and 41) The store's circuit breaker may have tripped, so please check this.
	<ul style="list-style-type: none"> • The AC power cord is unplugged either from the unit or from the outlet. 	<ul style="list-style-type: none"> • Connect the AC power cord correctly and securely (•Page 39) .
	<ul style="list-style-type: none"> • Circuit protector It's working. 	<ul style="list-style-type: none"> • Remove the cause and reset the circuit protector (•Page 182) .
There is nothing on the screen, but the lights are on.	<ul style="list-style-type: none"> • The power to the LCD adjustment board is turned OFF. 	<ul style="list-style-type: none"> • Turn on the power to the LCD adjustment board. (•Page 104)
	<ul style="list-style-type: none"> • The wire harness (connector) connected to the PCB unit is not connected properly. <ul style="list-style-type: none"> • The RGB cable is not connected properly. 	<ul style="list-style-type: none"> • Wire harness (connector) Connect the power adapter (USB 3.0 or later) correctly (•Pages 121 to 122) .
	<ul style="list-style-type: none"> • There is an abnormality in the PCB unit. • There is an abnormality in the LCD display. 	<ul style="list-style-type: none"> • Immediately turn off the main power switch, unplug the power cord from the outlet, and contact our after-sales service center.
The lights don't turn on. <ul style="list-style-type: none"> • Wire harness (connector) 	<ul style="list-style-type: none"> • The power adapter (main unit) is not connected correctly. 	<ul style="list-style-type: none"> • Wire harness (connector) Connect the power adapter (USB 3.0 or later) correctly (•Pages 121 to 122) .
		<ul style="list-style-type: none"> • If the problem persists even after taking the above measures, immediately turn off the main power switch, unplug the power cord from the outlet, and contact our after-sales service center.

Symptoms	Possible Cause	handle
_____	<ul style="list-style-type: none"> • The LCD display is not adjusted properly. 	<ul style="list-style-type: none"> • Immediately turn off the main power switch, unplug the power cord from the outlet, and contact our after-sales service center.
Even if you insert a coin, the screen The credits are not being counted correctly in the "CREDIT" section.	<ul style="list-style-type: none"> • There is an abnormality in the coin selector microswitch or the coin selector. 	<ul style="list-style-type: none"> • Check the operation by selecting "I/O CHECK >> INPUT CHECK" in the test mode. If it is abnormal, replace the microswitch. If it is normal, replace the coin selector. (•Page 56 , Page 159)
No sound or too quiet (too loud)	<ul style="list-style-type: none"> • The speaker volume control knob or woofer volume control knob on the service panel is turned down. • The wire harness (connector) connected to the PCB unit is not connected correctly. • The wire harness (connector) connected to the speaker is not connected correctly. 	<ul style="list-style-type: none"> • Adjust the speaker volume control knob and the woofer volume control knob by turning them to the right (•Page 41) . • Connect the wire harness (connector) correctly (•Pages 121 to 122) . • Immediately turn off the main power switch, unplug the power cord from the outlet, and contact our after-sales service center.
It does not start normally, errors occur frequently, or the following message appears during start-up:	<ul style="list-style-type: none"> • Something abnormal has occurred with the data on the hard disk. 	<ul style="list-style-type: none"> • Test mode "ROM (•Page 63) If "BAD" is displayed, immediately turn off the main power switch, unplug the power cord from the outlet, and contact our after-sales service center.

Symptoms	Possible Cause	handle
Some or all of the panels are not functioning.	• Wire harness in panel unit is loose.	• Wire harness (connector) Connect the power adapter (USB 3.0 or later) correctly (•Page 173) .
	• The contacts of the rubber switch on the panel are dirty.	• Remove any dirt from the rubber switch contacts (•Page 167) .
	• The wire harness (connector) connected to the PCB unit is loose.	• Wire harness (connector) Please connect the power adapter (USB 3.0 or later) correctly (•Page 121) .
	• Rubber switch on panel is broken.	• Replace the rubber switch (•Page 162) .
e-AMUSEMENT PASS is not recognized.	• There is an abnormality with the e-AMUSEMENT PASS or IC card reader.	• Check whether the e-AMUSEMENT PASS can be recognized using the IC card reader of another device. If it is not recognized , the e-AMUSEMENT PASS may be damaged. If it is recognized, there may be an abnormality in the IC card reader. Please take the following measures.
	• The connector of the IC card reader unit is disconnected or the wire harness is broken.	• Check whether the e-AMUSEMENT PASS is recognized by using the "IC CARD CHECK" test mode (•Page 65) . • • If the device is not recognized, please contact our after-sales service center.

Symptoms	Possible Cause	handle
	<ul style="list-style-type: none">• The procedure to use the e-AMUSEMENT service has not been completed.• Test mode The "e-AMUSEMENT" setting in "NETWORK OPTIONS" is set to "OFF."• The LAN cable is not connected correctly.	<ul style="list-style-type: none">• Please complete the procedure to use the e-AMUSEMENT service.• Set the "e-AMUSEMENT" setting to "ON" (•Page 74) .• Connect the LAN cable correctly (•Page 142)

ÿAbout network errors

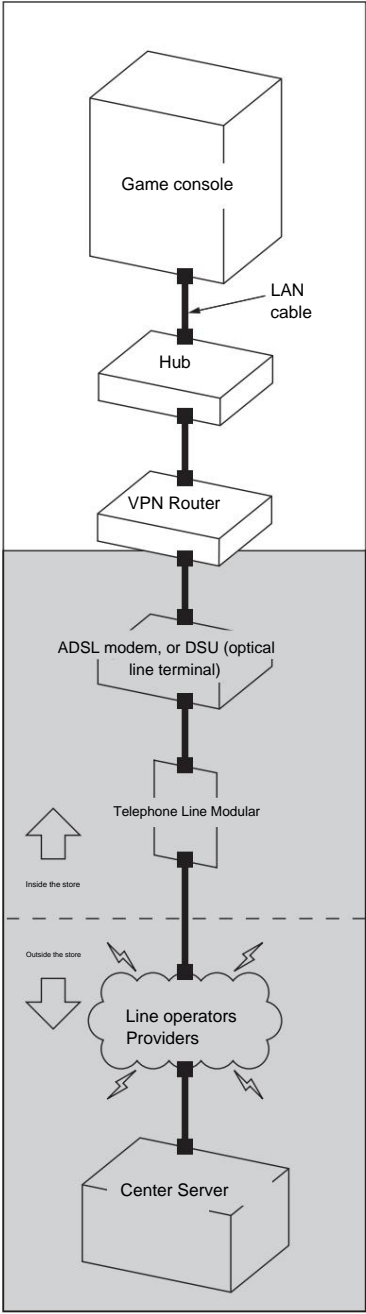

ÿ This error is displayed when using the e-AMUSEMENT service. - Even if the equipment is normal, online services may not be available due to line failures, etc. - If you are unable to connect to the network when using the e-AMUSEMENT service, this may be due to problems or maintenance on the part of your contracted line operator or provider. Please contact your line operator or provider, or check the status on their website.

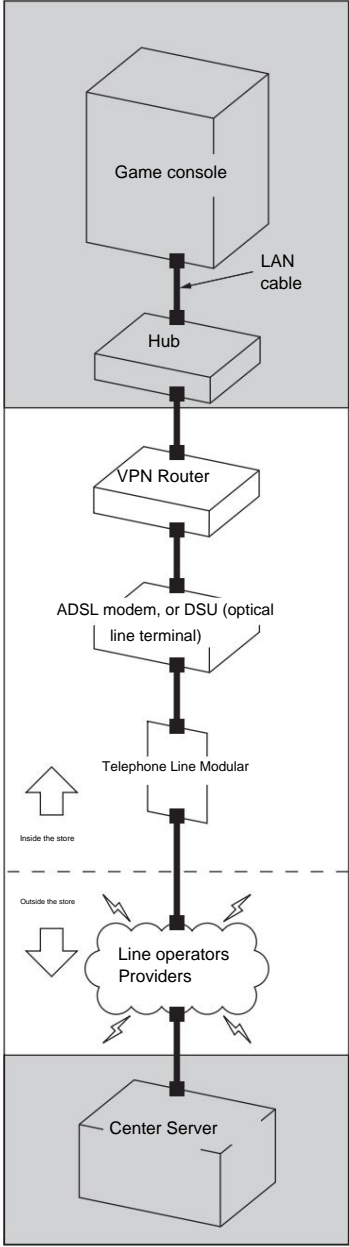

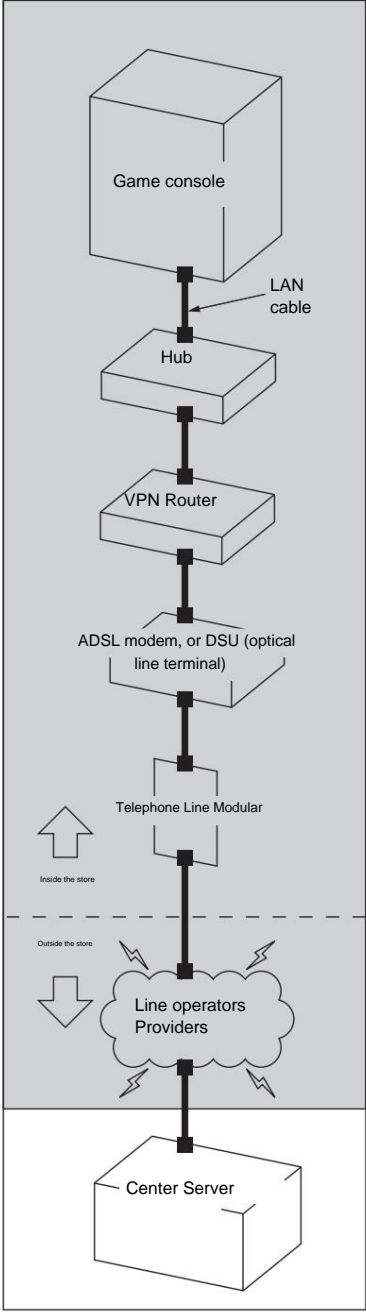
Symptoms	Possible Cause	handle
<p>The following message appears on the screen during startup or in game mode:</p> <div style="background-color: black; color: white; padding: 5px; text-align: center;"> NETWORK ERROR 5-2000- </div>	<p>ÿ The VPN router does not respond. (This is caused by the network in the store, including the VPN router.)</p> 	<p>When using the e-AMUSEMENT service ÿ Make sure that the VPN router and the in-store e-AMUSEMENT hub are turned on. ÿ Make sure that all LAN cables are connected from the VPN router to the hub, and from the hub to the main unit. (ÿPage 142)</p> <p>ÿ Turn off the main power switch of this product, wait at least 10 seconds, then turn it on again.</p> <p>ÿ If the power does not return to normal , turn off the power and contact the after-sales service center.</p> <div style="border: 1px solid black; padding: 5px; margin-top: 10px;"> <p>MEMO</p> <p>ÿ By pressing the service button while the message is displayed, you can play while checking the network connection status. In this case, you cannot use the e-AMUSEMENT service.</p> </div> <p>If you do not use the e-AMUSEMENT service ÿ In test mode, Set "e-AMUSEMENT" in "NETWORK OPTIONS" to "OFF" (ÿPage 74) .</p> <p>ÿ Please remove the LAN cable between the LAN port on the main unit and the e-AMUSEMENT hub, then restart the device.</p>

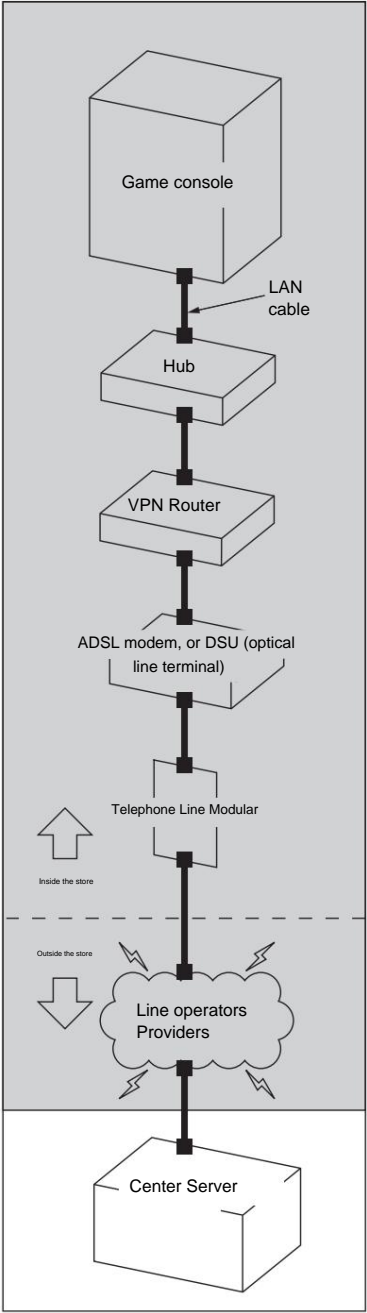
Symptoms	Possible Cause	handle
<p>The following message appears on the screen during startup or in game mode:</p> <div style="border: 1px solid black; background-color: black; color: white; padding: 5px; margin: 10px 0;"> <p>NETWORK ERROR 5-2002-</p> </div> <p>5-2003-**** 5-2007-**** 5-2008-**** 5-2009-****</p>	<p>ÿ The center server does not respond. (This is caused by the network inside or outside the store, including the VPN router. In this case, you cannot play using e-AMUSEMENT PASS.)</p>  <p>The diagram illustrates the network connection path. It is divided into three horizontal sections. The top section, labeled 'Inside the store', contains a Game console connected to a Hub via a LAN cable. The middle section, also labeled 'Inside the store', contains a VPN Router connected to the Hub, an ADSL modem or DSU (optical line terminal) connected to the VPN Router, and a Telephone Line Modular connected to the ADSL modem. The bottom section, labeled 'Outside the store', contains a cloud representing Line operators Providers connected to the Telephone Line Modular. At the very bottom, a Center Server is connected to the Line operators Providers. Arrows indicate the flow of data from the game console through the various components to the center server.</p>	<p>If the problem is within the store: ÿ Make sure that all connected devices, from the VPN router to the indoor telephone line modular, are turned on.</p> <p>ÿ If the system does not recover ÿ Check that the LAN cable from the VPN router to the indoor telephone line modular and all connected devices are properly connected.</p> <p>ÿ If the power does not return to normal, turn off the power and contact the after-sales service center.</p> <div style="border: 1px solid black; padding: 5px; margin: 10px 0;"> <p>MEMO</p> <p>ÿ By pressing the service button while the message is displayed, you can play while checking the network connection status. In this case, you cannot use the e-AMUSEMENT service.</p> </div>
	<p>ÿ This line cannot be used for the e-AMUSEMENT service.</p> <p>ÿ The lines are very congested. do.</p>	<p>ÿ There may be an error in the store registration information or line registration information. Please contact the after-sales service desk. If the cause is outside the store ÿ Please wait until the line situation is restored.</p>

Symptoms	Possible Cause	handle
<p>The following message appears on the screen during startup or in game mode:</p> <div data-bbox="172 376 523 443" style="background-color: black; color: white; padding: 5px; margin-bottom: 10px;"> NETWORK ERROR 5-2004- </div> <div data-bbox="172 472 523 539" style="background-color: black; color: white; padding: 5px;"> NETWORK ERROR 5-2005- </div> <p>(Continued)</p>	<p>• The procedure for using the e-AMUSEMENT service has not been completed.</p> 	<p>If you wish to use the e-AMUSEMENT service • Please complete the procedure to use the e-AMUSEMENT service. • In test mode Set the "e-AMUSEMENT" setting in "NETWORK OPTIONS" to "ON" (•Page 74).</p> <div data-bbox="967 689 1369 909" style="border: 1px solid black; padding: 5px; margin-top: 20px;"> <p>MEMO •</p> <p>You can play without using the e-AMUSEMENT service by pressing the service button while the message is displayed.</p> </div> <p>If you do not use the e-AMUSEMENT service • In test mode, Set "e-AMUSEMENT" in "NETWORK OPTIONS" to "OFF" (•Page 74).</p> <p>•</p> <p>Remove the LAN cable between the LAN port on the main unit and the e-AMUSEMENT hub, then restart the system (•Page 142).</p>

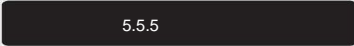
Symptoms	Possible Cause	handle
<p>(continued) The following message appears on the screen during startup or in game mode:</p> <div data-bbox="245 405 601 488" style="background-color: black; color: white; padding: 5px; margin-bottom: 5px;"> NETWORK ERROR 5-2004- </div> <div data-bbox="245 501 601 584" style="background-color: black; color: white; padding: 5px;"> NETWORK ERROR 5-2005- </div>	<p>Unable to communicate properly with the central server.</p> 	<p>Turn off the main power switch, wait for 10 seconds or more, then turn it on again.</p> <p>If the power does not return to normal : Make sure that all connected devices, from the unit to the VPN router and indoor telephone line modular, are turned on.</p> <p>If the connection does not recover, check the distance from the unit to the VPN router and the indoor telephone line modular. Check that the LAN cable and all connected devices are properly connected.</p>

Symptoms	Possible Cause	handle
<p>The following message appears on the screen during startup or in game mode:</p> 	<p>• The e-AMUSEMENT service period for this product has ended.</p> <div style="border: 1px solid black; padding: 5px; margin: 10px 0;"> <p>MEMO • Play using the e-AMUSEMENT service is not possible.</p> </div>	<p>• In test mode, Set "e-AMUSEMENT" in "NETWORK OPTIONS" to "OFF", then turn off the main power switch (•Page 74) .</p> <p>•</p> <p>Remove the LAN cable between the LAN port on the main unit, the e-AMUSEMENT hub, and this product, then restart the system (•Page 142) .</p>
<p>The following message appears during start-up or on the screen:</p> 	<p>• The network is cut off Ta.</p>	<p>• Please wait a while until it returns to normal.</p> <p>•</p> <p>If the system does not recover • Check that all connected devices from the VPN router to the indoor telephone line modular are powered on. • If the system does not recover • Check that the cables from the VPN router to the indoor telephone line modular and all connected devices are properly connected. • If the system does not recover • Turn off the power and contact an after-sales service center.</p>
<p>The following message appears during start-up or on the screen:</p> 	<p>• The IP address has changed.</p> <p>• The VPN router does not respond. (This is caused by the network in the store, including the VPN router.)</p>	<p>• Try turning the power switch of each device off and on again.</p> <p>• Make sure that all LAN cables are properly connected from the VPN router to the hub, and from the hub to the game console.</p>

Symptoms	Possible Cause	handle
		<p>ÿ Please wait until the maintenance is completed.</p>
		<p>ÿ Fix the problem and restart the device. When you are not using the e-AMUSEMENT service ÿ In test mode, set "e-AMUSEMENT" in "NETWORK OPTIONS" to "OFF" (ÿPage 74) .</p>
<p>Online services provided by e-AMUSEMENT are not available.</p>	<p>ÿ The center server is undergoing maintenance.</p> <p>ÿ The network line was cut off.</p>	<p>ÿ Please wait until the maintenance is completed.</p> <p>ÿ Please wait until the line condition improves.</p> <p>ÿ If the power does not return to normal : ÿ Make sure that all connected devices, from the unit to the VPN router and indoor telephone line modular, are turned on.</p> <p>ÿ If the connection does not recover, check the distance from the unit to the VPN router and the indoor telephone line modular. Check that the LAN cable and all connected devices are properly connected.</p>
<p>The following message appears on the screen when starting up or while playing.</p> 	<p>ÿ "e-AMUSEMENT service usage confirmation" has not been performed.</p>	<p>ÿ Turn off the main power switch, wait for 10 seconds or more, then turn it on again.</p> <p>ÿPlease confirm your e-AMUSEMENT service usage . (ÿPage 145)</p>

Error Codes and Messages



• Before taking any action, be sure to turn off the main power switch and unplug the power cord from the outlet. • After turning off the power, wait at least 10 seconds before restarting the unit.

• If you are unsure of how to take action, do not try to do it yourself but contact the after-sales service center.

Inquire

• If the problem persists after taking the corrective action, or if an error code or message not listed in this manual appears, write down the error code or message, turn off the main power switch, unplug the power cord from the outlet, and contact our after-sales service center.

If an error code or message appears on the screen, try the following solutions:

Error Code	Message	Possible Cause	handle
1-1601-0008 1-1601-0009	DISK ERROR	• The hard disk is broken. do.	• Check the hard disk connection and restart the computer. (Page 175) • If the same symptoms persist even after restarting the computer, contact the after-sales service center.
1-1602-****	I/O BOARD ERROR	• The I/O board did not initialize properly.	• Please contact our after-sales service desk.
1-1603-****	SYSTEM DRIVE ERROR	• The hard disk is broken. do.	• Please restart the device. • If the same symptoms persist after restarting the device, please contact our after-sales service center.
1-1604-****	SYSTEM FILE ERROR	• The hard disk is broken. do.	• Please restart the device. • If the same symptoms persist after restarting the device, please contact our after-sales service center.
1-1605-****	CHKDSK ERROR	• The hard disk is faulty.	• Please restart the device. • If the same symptoms persist after restarting the device, please contact our after-sales service center.
1-1606-****	CLOCK ERROR	• The system clock is faulty.	• Please restart the device. • If the same symptoms persist after restarting the device, please contact our after-sales service center.
1-2601-06** 1-2601-08** 1-2601-09**	The update will be interrupted	• The hard disk is broken. do.	• Please restart the device. • If the same symptoms persist after restarting the device, please contact our after-sales service center.
2-1000-00**	Application startup failed	• The application could not be started. • There is an error in the startup program. do. • There is an abnormality in the PCB unit.	• Please restart the device. • If the same symptoms persist after restarting the device, please contact our after-sales service center.

The value displayed in the "*" mark section of the error code will vary depending on the condition.

Error Code	Message	Possible Cause	handle
2-1001-0007	Security Error	<ul style="list-style-type: none"> • The license key (black) is not connected properly. • There is an error in the license key (black). • A license key (black) other than that for this product is connected. 	<ul style="list-style-type: none"> • Turn off the power, check the connection of the license key (black), and restart the computer. (Page 138) • If the same symptoms persist even after restarting the computer, contact the after-sales service center.
2-1001-0017	Security module initialization failed	<ul style="list-style-type: none"> • Security module initialization failed. 	<ul style="list-style-type: none"> • Please restart the device. • If the same symptoms persist after restarting the device, please contact our after-sales service center.
5-1501-****	I/O BOARD ERROR	<ul style="list-style-type: none"> • The I/O board did not initialize properly. 	<ul style="list-style-type: none"> • Please contact our after-sales service desk.
5-1502-****	HDD READ ERROR	<ul style="list-style-type: none"> • An error occurred while reading from the hard disk. 	<ul style="list-style-type: none"> • Please restart the device. • If the same symptoms persist after restarting the device, please contact our after-sales service center.
5-1503-0001	SECURITY ERROR	<ul style="list-style-type: none"> • The security plug (black) is not connected properly. • There is an abnormality in the security plug (black). • A security plug (black) other than this product is connected. 	<ul style="list-style-type: none"> • Turn off the power, check the connection of the security plug (black), and restart the unit. (Page 140) • If the same symptoms persist even after restarting the unit, contact the after-sales service center.
5-1503-0101	SECURITY ERROR	<ul style="list-style-type: none"> • The license key (black) is not connected properly. • There is an error in the license key (black). • A license key (black) other than that for this product is connected. 	<ul style="list-style-type: none"> • Turn off the power, check the connection of the license key (black), and restart the computer. (Page 138) • If the same symptoms persist even after restarting the computer, contact the after-sales service center.
5-1503-0102	SECURITY ERROR	<ul style="list-style-type: none"> • The account key (white) is not connected properly. • There is an error in the account key (white). 	<ul style="list-style-type: none"> • Turn off the power, check the connection of the account key (white), and restart the device. (Page 138) • If the same symptoms persist even after restarting the device, contact the after-sales service center.
5-1505-****	SYSTEM ERROR	<ul style="list-style-type: none"> • An unexpected error occurred in the system. 	<ul style="list-style-type: none"> • Please restart the device. • If the same symptoms persist after restarting the device, please contact our after-sales service center.
5-1506-****	IP address has changed	<ul style="list-style-type: none"> • The IP address has changed from the one obtained at startup. 	<ul style="list-style-type: none"> • Make sure that all devices, including the router, are turned on. • Check that the LAN cable between the router and the unit is connected properly. • After checking the above, reboot the unit.
5-1698-**** 5-1699-****	Application Error	<ul style="list-style-type: none"> • An unexpected error occurred in the system. 	<ul style="list-style-type: none"> • Please restart the device. • If the same symptoms persist after restarting the device, please contact our after-sales service center.

The value displayed in the "*" mark section of the error code will vary depending on the condition.

Error Code	Message	Possible Cause	handle
5-2000-****	Unable to communicate with router	<ul style="list-style-type: none"> Unable to communicate properly with the VPN router. (There is a problem with the in-store network including the VPN router.) 	<ul style="list-style-type: none"> Make sure all devices, including the router, are powered on. Check the connection of the LAN cable between the router and the main unit.
5-2002-**** 5-2003-****	Unable to communicate with the central server	<ul style="list-style-type: none"> Unable to communicate properly with the central server. (There is a problem with the off-site network including the VPN router) 	<ul style="list-style-type: none"> Make sure the router is turned on. Check the connection of the LAN cable between the router and the e-AMUSEMENT dedicated line.
5-2004-**** 5-2005-****	This console is not registered	<ul style="list-style-type: none"> The procedure for using the e-AMUSEMENT service has not been completed. 	<ul style="list-style-type: none"> Please complete the procedure to use the e-AMUSEMENT service.
5-2006-****	The online service period has ended.	<ul style="list-style-type: none"> The e-AMUSEMENT service period for this product has ended. 	<ul style="list-style-type: none"> Set "e-AMUSEMENT OFF" in "NETWORK OPTIONS" in test mode (Page 74) .
5-2007-**** 5-2008-****	Unable to communicate with the central server.	<ul style="list-style-type: none"> Unable to connect correctly to the central server. (There is a problem with the off-site network including the VPN router) 	<ul style="list-style-type: none"> Make sure the router is turned on. Check the connection of the LAN cable between the router and the e-AMUSEMENT dedicated line.
5-2009-****	Unable to communicate with the central server.	<ul style="list-style-type: none"> You are connected to a line that does not support the e-AMUSEMENT service. 	<ul style="list-style-type: none"> Connect to the e-AMUSEMENT dedicated line Please continue.
5-2500-0000 5-2500-0001 5-2500-0002	BACKUP DATA ERROR	<ul style="list-style-type: none"> Corruption was found in backup data or configuration files. 	<ul style="list-style-type: none"> Follow the instructions on the screen. Please reset the backup data and configuration files, and configure various settings in test mode.
5-2502-****	IC CARD UNIT ERROR	<ul style="list-style-type: none"> There is an abnormality in the IC card reader unit. 	<ul style="list-style-type: none"> Please contact our after-sales service desk.
5-2504-****	LED BOARD ERROR	<ul style="list-style-type: none"> There is an abnormality in the LED board. 	<ul style="list-style-type: none"> Please contact our after-sales service desk.
5-2505-****	IC CARD UNIT/ LED BOARD NOT FOUND	<ul style="list-style-type: none"> The IC card reader unit or LED board cannot be detected. 	<ul style="list-style-type: none"> Check the PCB unit connection. (Pages 121 to 122) If the above measures do not improve the situation, contact the after-sales service desk.

The value displayed in the "*" mark section of the error code will vary depending on the condition.

12 Appendix

200 12 Accessory

decorative parts

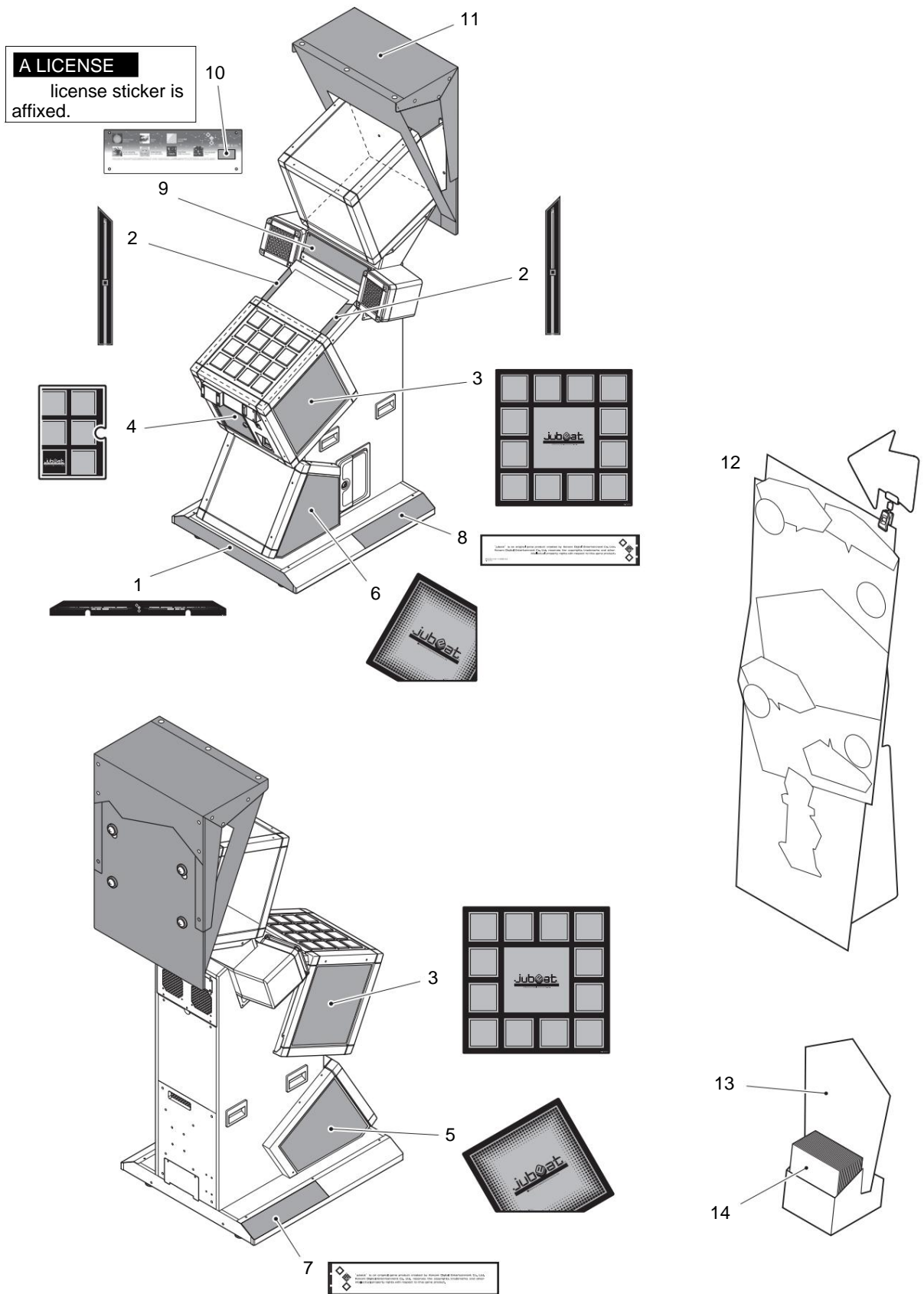

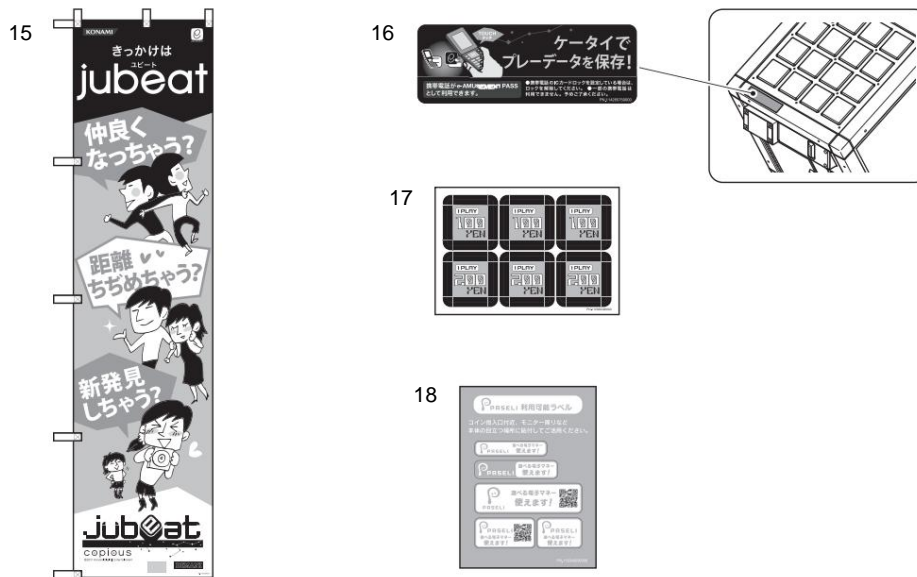

*Poles are not included.
Please use your own pole.
Sai.

No.	Part Number	Product Name	Quantity	remarks
1	112366420000	LABEL, FRONT	1	
2	112366370000	LABEL, COVERLATTICE	1	Left and right set
3	112366380000	LABEL, SIDE, H	2	
4	112366390000	LABEL, CENTER	1	
5	112366400000	LABEL, SIDE, L/L	1	
6	112366410000	LABEL, SIDE, L/R	1	
7	112366430000	LABEL, COVERFLOOR/L	1	
8	112366440000	LABEL, COVERFLOOR/R	1	
9	114628680000	PANEL, CENTER	1	See Fig.22 ASS'Y, SPEAKER BOX
10	-	SEAL, LICENSE	1	
11	114263370000	ASS'Y, POP, U	1	Pop set (instructions included)
12	114263320000	ASS'Y, STANDPOP	1	Separate pop set (instructions included)
13	114263260000	POP, INST. CASE	1	Leaflet stand
14	-	ASS'Y, SHEET, INST	2	Leaflets (50 sheets x 2)
15	114263400000	ASS'Y, POP, FLAG	1	Flag (instructions included)
16	114265750000	LABEL, FELI	1	IC card reader information label
17	112366490000	LABEL, COIN	1	Coin Label
18	113349230000	LABEL, PASELI	1	PASELI Seal

The label contents may vary depending on the shipping time.

Parts Diagram

Fig.1 Assembly, MAIN PCB

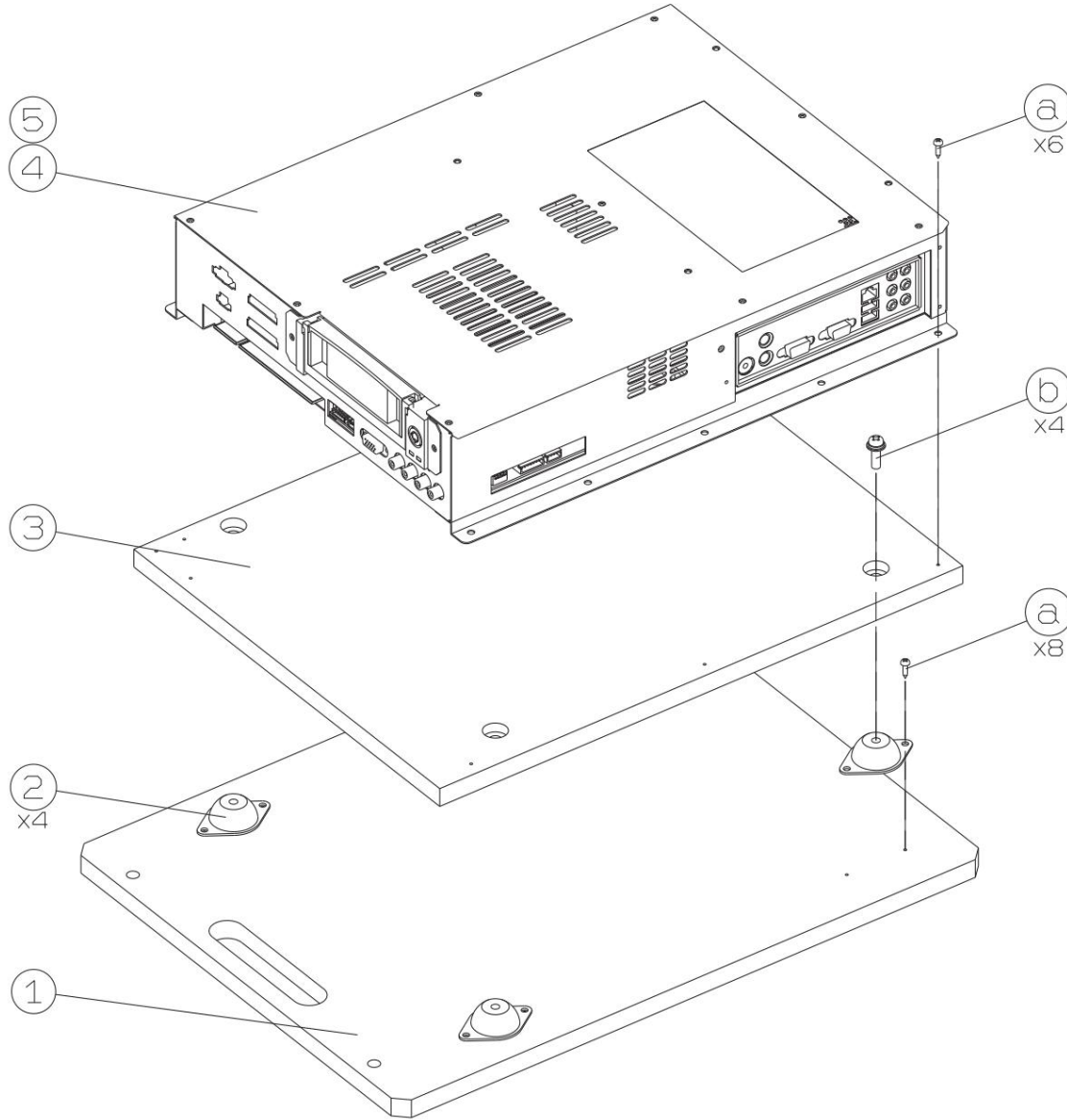

Assembly, main PCB

No.	Part Number	Product name	Model/Specification	Quantity	remarks
1	112373660000	BASE PCB(A)		1	
2	112013080000	RUBBER,VIB.CTRL.		4	
3	112391260000	BASE PCB(B)		1	
4	114641010000	UNIT, PCB BOX		1	"B" label attached
5		Unit, HDD		1	

Assembly, Main PCB Screws and auxiliary materials

No.	Item Name	Quantity	Model/Specifications	Quantity	remarks
a	Cross recessed wood screw 14 Chromate		Call 3.1x13		
b	Washer assembled cross recessed pan head screw M6x20 SW,PW (No. 2 + polished round)	4	Chromate		

The parts contents may vary depending on the shipping time.

Fig.2 Assembly, base

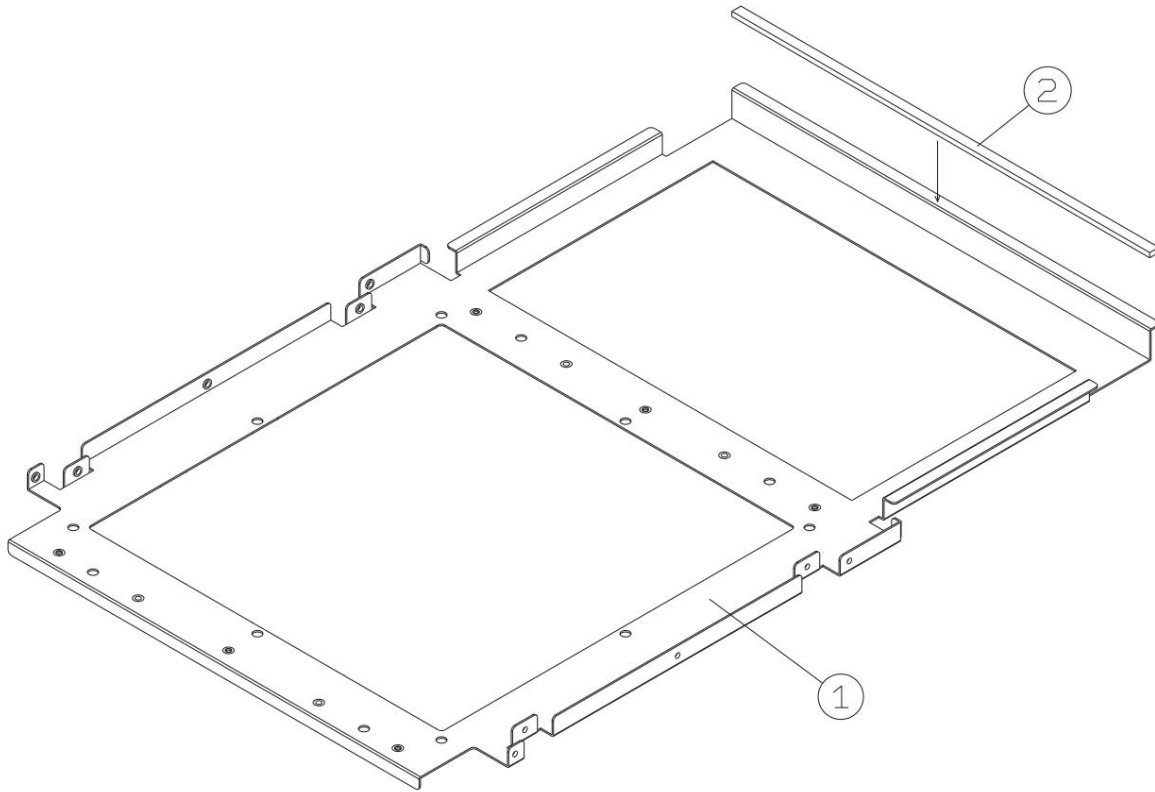

Assembly, Base

No.	Part Number	Product name	Model/Specification	Quantity	remarks
1	112883660000	BRACKET,BASE		1	
2	112368600000	TAPE,SPONGE(F)		1	

The parts contents may vary depending on the shipping time.

Fig.3 UNIT, CONTROL (1/2)

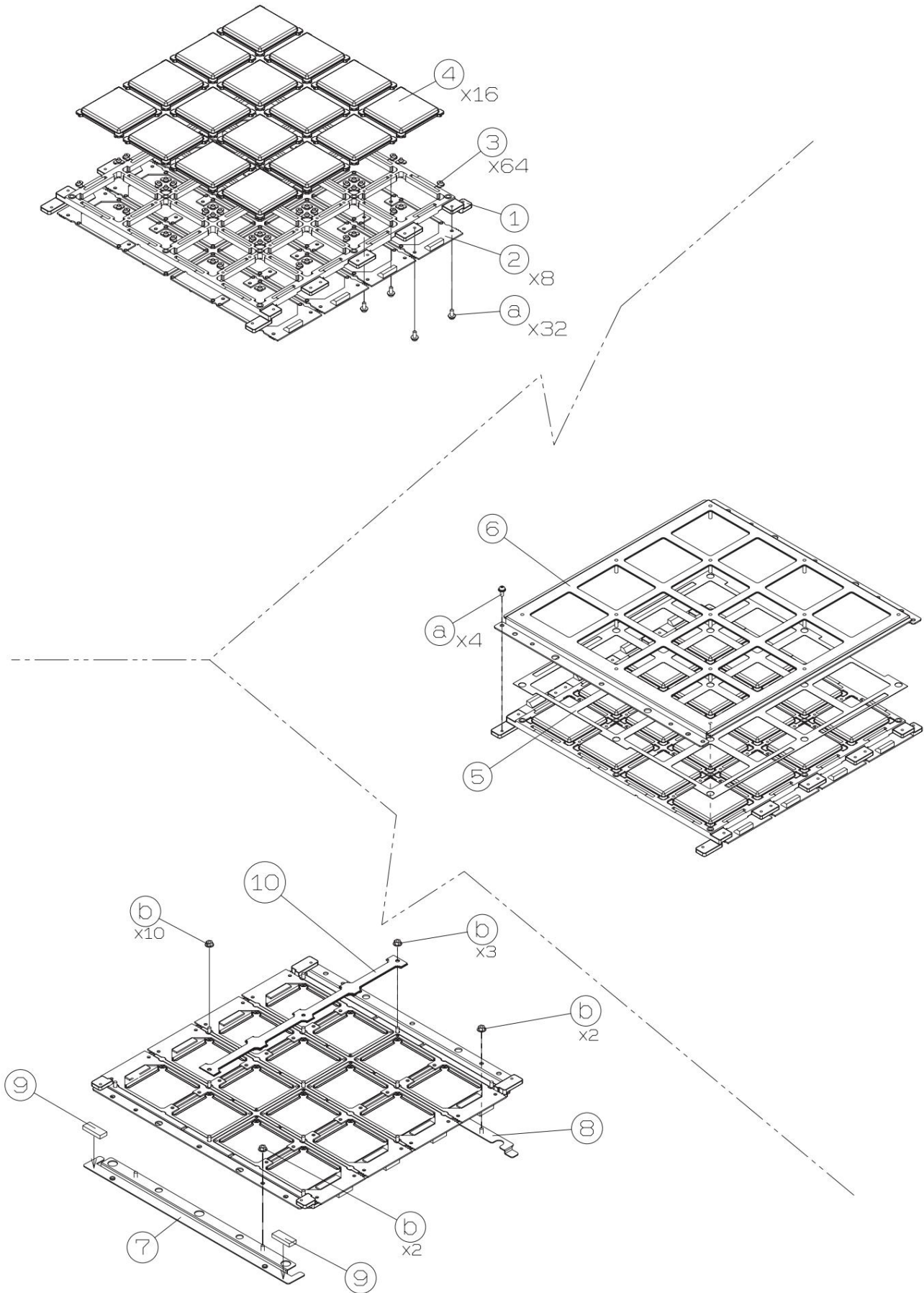

UNIT, CONTROL(1/2)

No.	Part Number	Product name	Model/Specifications	Quantity	Notes
1	112317130000	LATTICE		1	
2	112518860000	UNIT,PCB(D)		8	
3	112317280000	CONTACT,RUBBER		64	Consumables
4	112317140000	PANEL, BUTTON		16	
5	112368510000	COVER, BUTTON		1	
6	112899360000	COVER, LATTICE		1	
7	112899370000	FIXTURE,FRAME(UP)		1	
8	112899380000	FIXTURE,FRAME(LOW)		1	
9	112483610000	TAPE SPONGE(H)		2	
10	12737880000	ASS'Y, STOPPER		1	

UNIT, CONTROL(1/2) Screws and auxiliary materials

No.	Product name	Model/Specifications	Quantity	remarks
a	Washer assembled cross recessed pan head screw	M3x8 SW,PW (No. 2 + polished round)	36	Trivalent chromate
b	Flanged hex nut	M4	17	Trivalent chromate with serrations

The parts contents may vary depending on the shipping time.

Fig.4 UNIT, CONTROL (2/2)

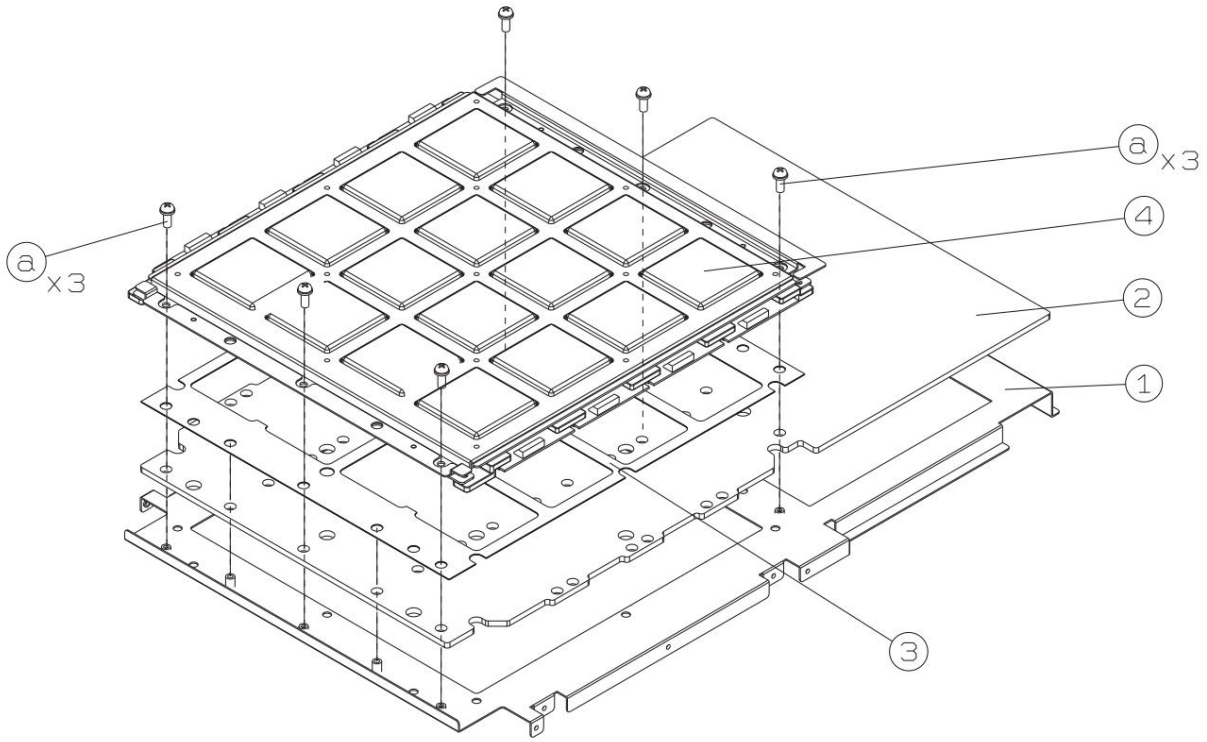

UNIT, CONTROL(2/2)

No.	Part number	Product name	Model/Specifications	Quantity	Notes
1	112901040000	ASSY,BASE		1	See Fig.2
2	112368380000	BASE, LATTICE		1	
3	112368520000	FLOOR, BUTTON		1	
4		UNIT, CONTROL(1/2)		1	See Fig. 3

UNIT,CONTROL(2/2) Screws and auxiliary materials

No.	Item Name	Quantity	Model/Specifications	remarks
a	Washer assembled cross recessed pan head screw M4x12 SW,PW (No.2 + polished round) 6 Trivalent chromate			

The parts contents may vary depending on the shipping time.

Fig.5 Assembly, power panel

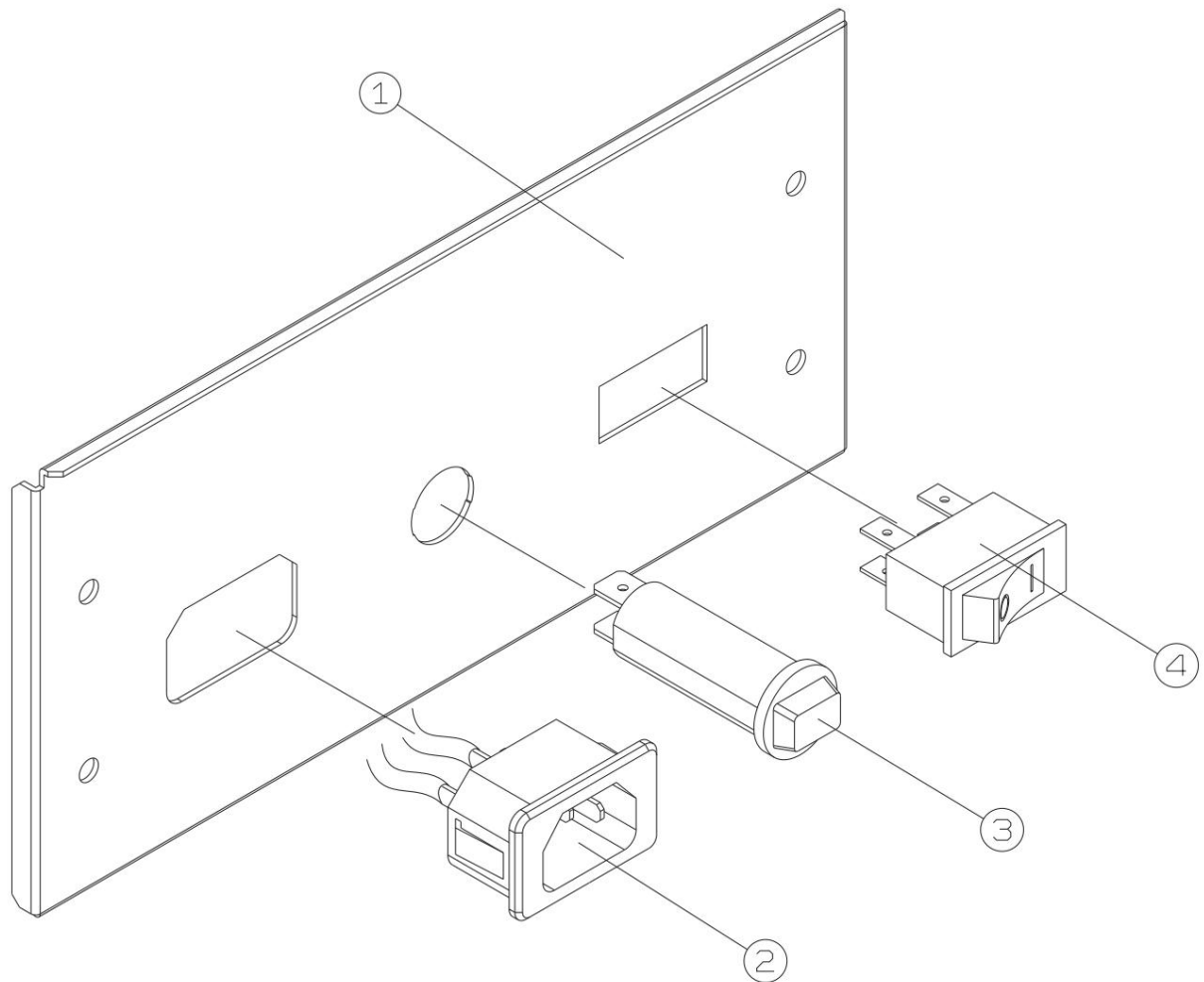

Assembly, power panel

No.	Part Number	Product name	Model/Specification	Quantity	remarks
1	112373800000	PANEL, POWER		1	
2	113535340000	WIRING HARNESS		1	
3	112330420000	PROTECTOR, CIRCUIT		1	
4	110794730000	SWITCH, ROCKER		1	

The parts contents may vary depending on the shipping time.

Fig.6 Assembly, power box

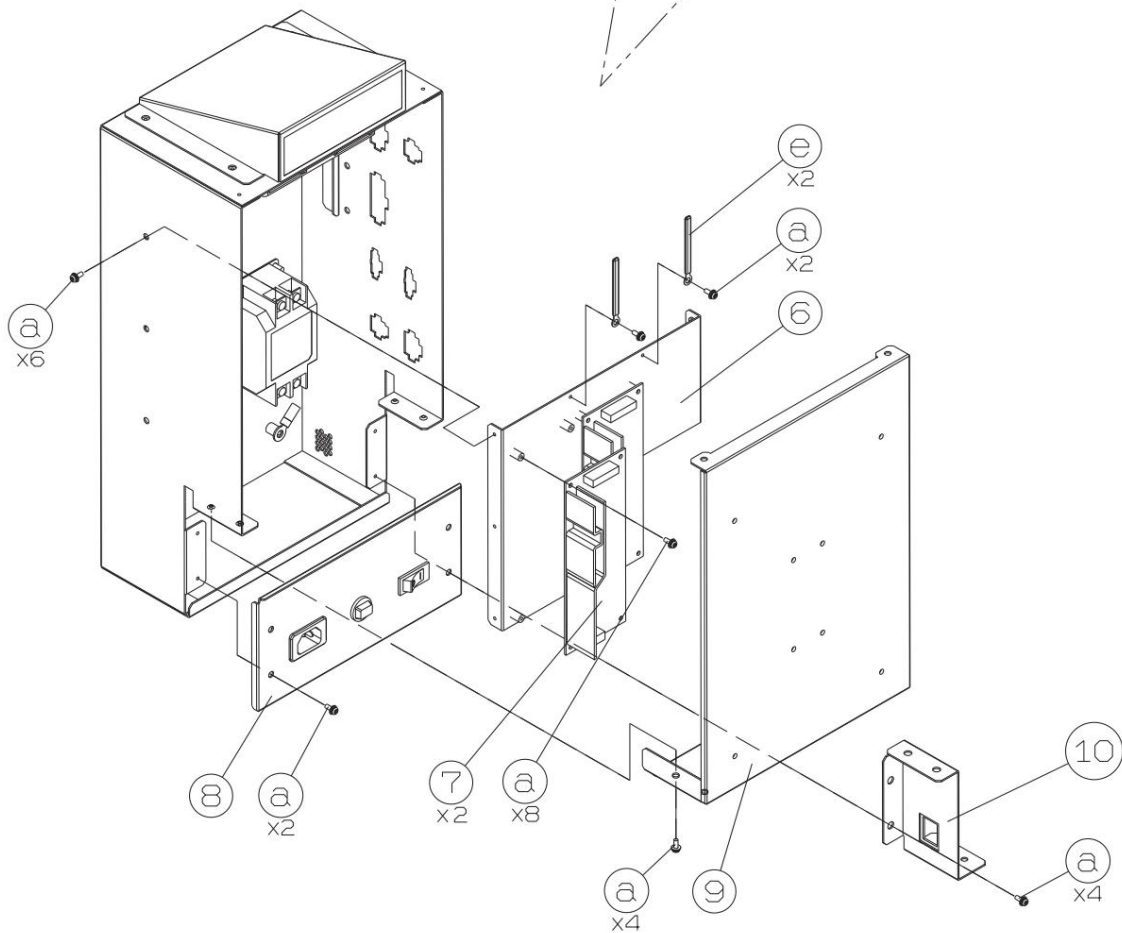
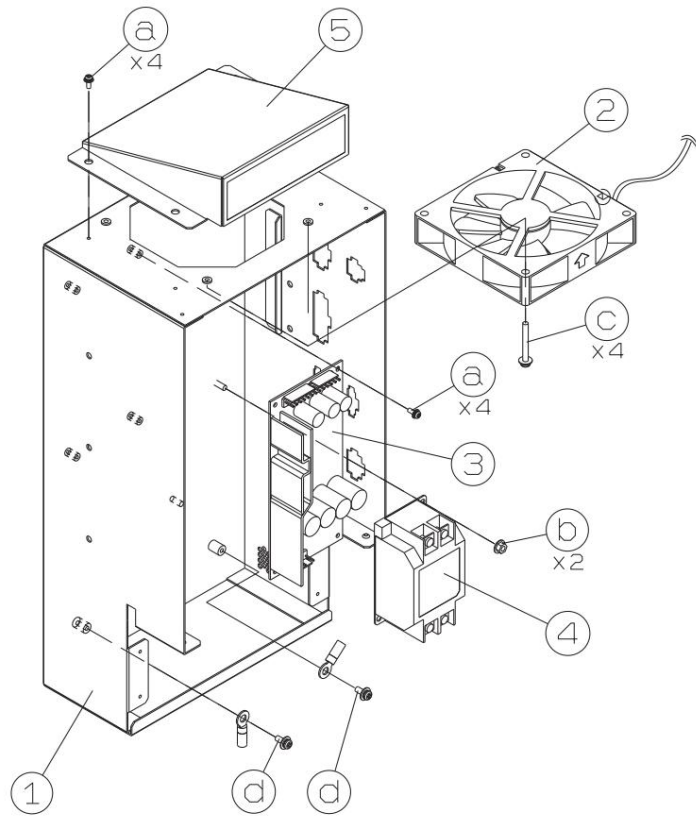

Assembly, power box

No.	Part Number	Product name	Model/Specification	Quantity	Remarks
1	114375680000	BOX, POWER		1	
2	112302600000	MOTOR, FAN		1	
3	114303770000	REG. SWITCHING		1	
4	111995190000	FILTER, NOISE		1	
5	112373810000	DUCT		1	
6	114375690000	BRACKET, REG.		1	
7	113033050000	SUPPLY, POWER		2	
8	113535880000	ASS'Y, POWER PANEL		1	See Fig. 5
9	114375670000	COVER, POWER		1	
10	112373830000	FIXTURE, CONNECTOR		1	

Assembly, power box screws and spare parts

No.	Product name	Model/Specifications	Quantity	remarks
a	Washer assembled cross recessed pan head screw M3x8 SW,PW (No. 2 + polished round)		34	Chromate
b	Hexagonal flange nut c Pan	M4	2	Chromate with serrations
	head screw with washer M4x35 SW,PW (No. 2 + polished round)		4	Chromate
d	Washer assembled cross recessed pan head screw M4x10 SW,PW (No. 2 + polished round)		2	Chromate
e	Coaching Clip	CS-7 (γ4.4 L76)	2	

The parts contents may vary depending on the shipping time.

Fig.7 ASS'Y, COIN DOOR

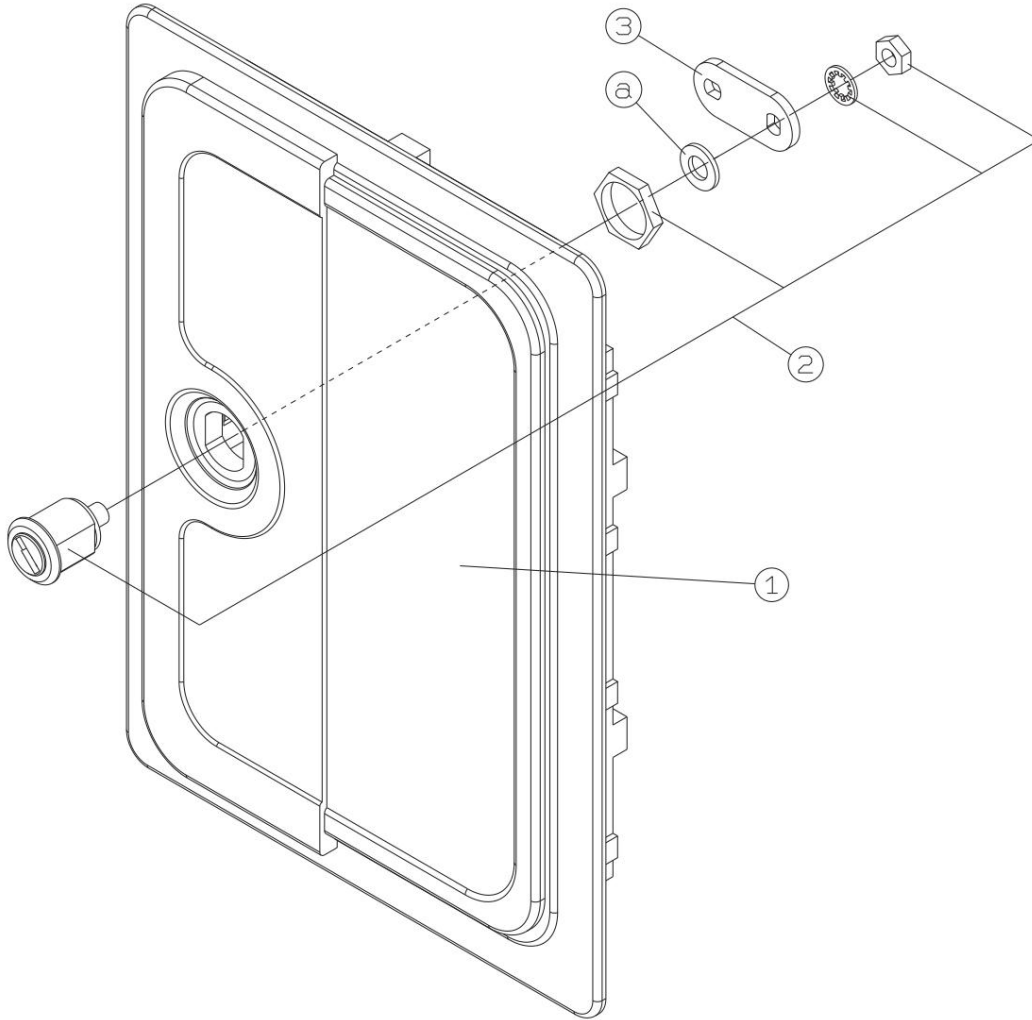

ASS'Y, COIN DOOR

No.	Part Number	Product name	Model/Specification	Quantity	remarks
1	111688690000	DOOR, CASH BOX		1	
2	002652030000	LOCK		1 2	keys + cylinder
3	002544330000	PLATE, LOCK		1	

Assembly, coin door screws and spare parts

No.	Product name	Model/Specifications	Quantity	remarks
a	Flat washer	Call 8 D15,T2	1 Chrome	

The parts contents may vary depending on the shipping time.

Fig.8 ASS'Y, COVER (AT)

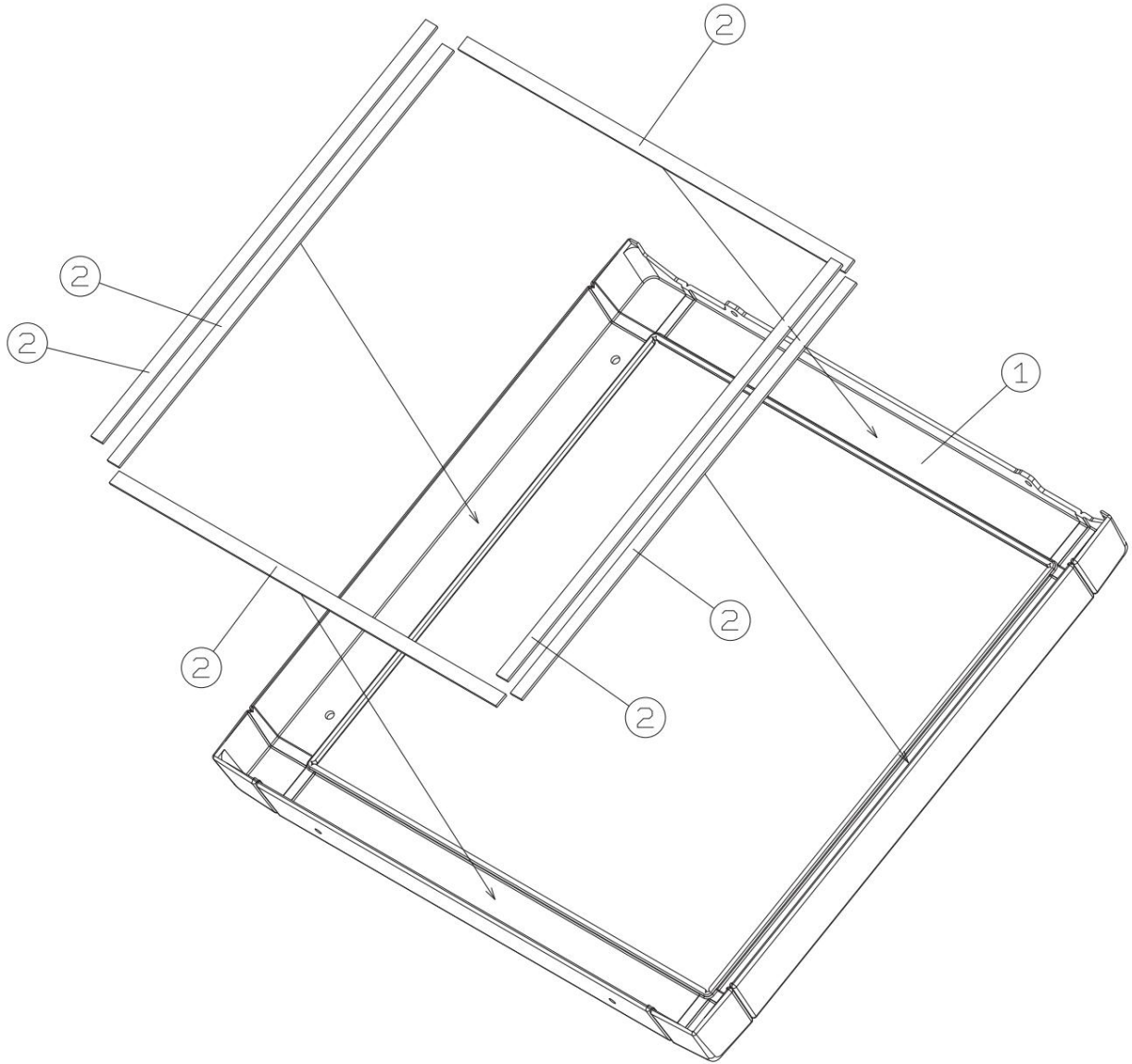

Assembly, Cover (AT)

No.	Part Number	Product name	Model/Specification	Quantity	remarks
1	112317170000 COVER	CUBE(AT)		1	
2	112368550000 TAPE,S	PONGE(A)		6	

The parts contents may vary depending on the shipping time.

Fig.9 ASS'Y, WOOFER LED

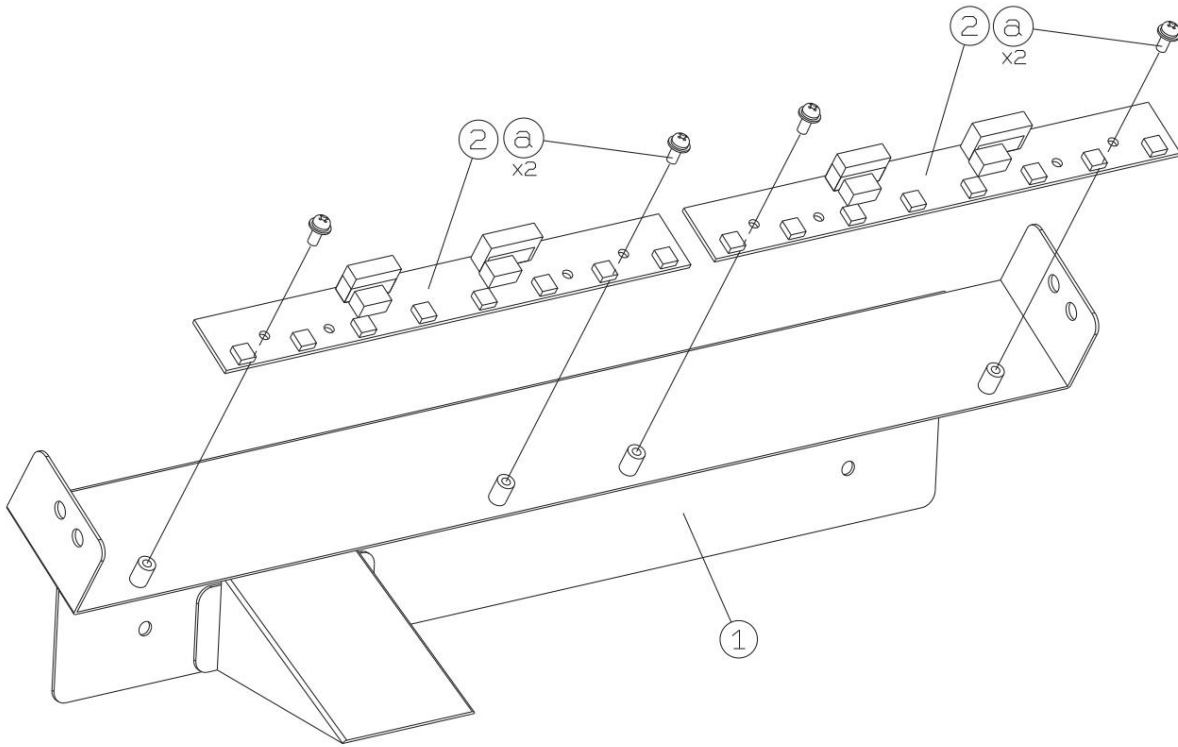

Assembly, Woofer LED

No.	Part Number	Product name	Model/Specification	Quantity	Remarks
1	112885360000	FRAME, WOOFER(UP)		1	
2	114659100000	UNIT, PCB(C)		2	

ASS'Y, WOOFER LED Screws and spare parts

No.	Product name	Model/Specifications	Quantity	remarks
	a Washer assembled cross recessed pan head screw M3x8 SW,PW (No. 2 + polished round)		4	Chromate

The parts contents may vary depending on the shipping time.

Fig.10 Assembly, coin mechanism

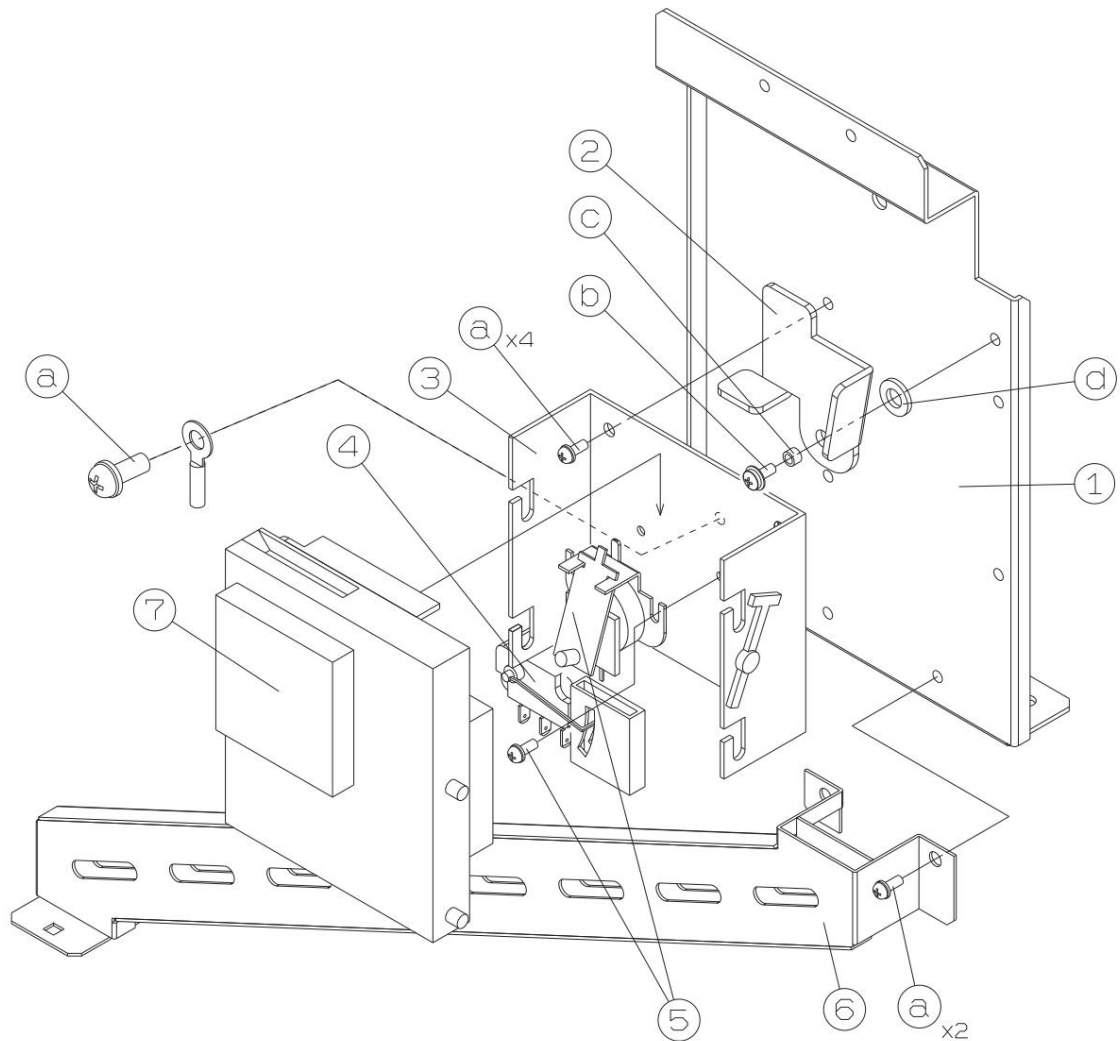

ASS'Y, COIN MECH

No.	Part Number	Product name	Model/Specification	Quantity	remarks
1	112373980000	BRACKET,SELECTOR		1	
2	112899870000	PLATE,ARM		1	
3	111764230000	BRACKET,CHANNEL		1	Including No.4
4	111718820000	SWITCH,MICRO	V4-5210M-A	1	Consumables
5	113176390000	BLOCKER		1	screw included
6	112373970000	RAIL, COIN(B)		1	
7	111718780000	SELECTOR,COIN		1	

ASS'Y, COIN MECH Screws and spare parts

No.	Product name	Model/Specifications	Quantity	remarks
a	Washer assembled cross recessed pan head screw M4x10 SW,PW (No. 2 + polished round)		7	Chromate
b	TP machine screw 1 Trivalent chromate	M4x8		
c	Spacer 1 Trivalent chromate	Call 4 L=4		
d	PDM washer	CC-0612-08	1	PCM

The parts contents may vary depending on the shipping time.

Fig.11 Assembly, Service

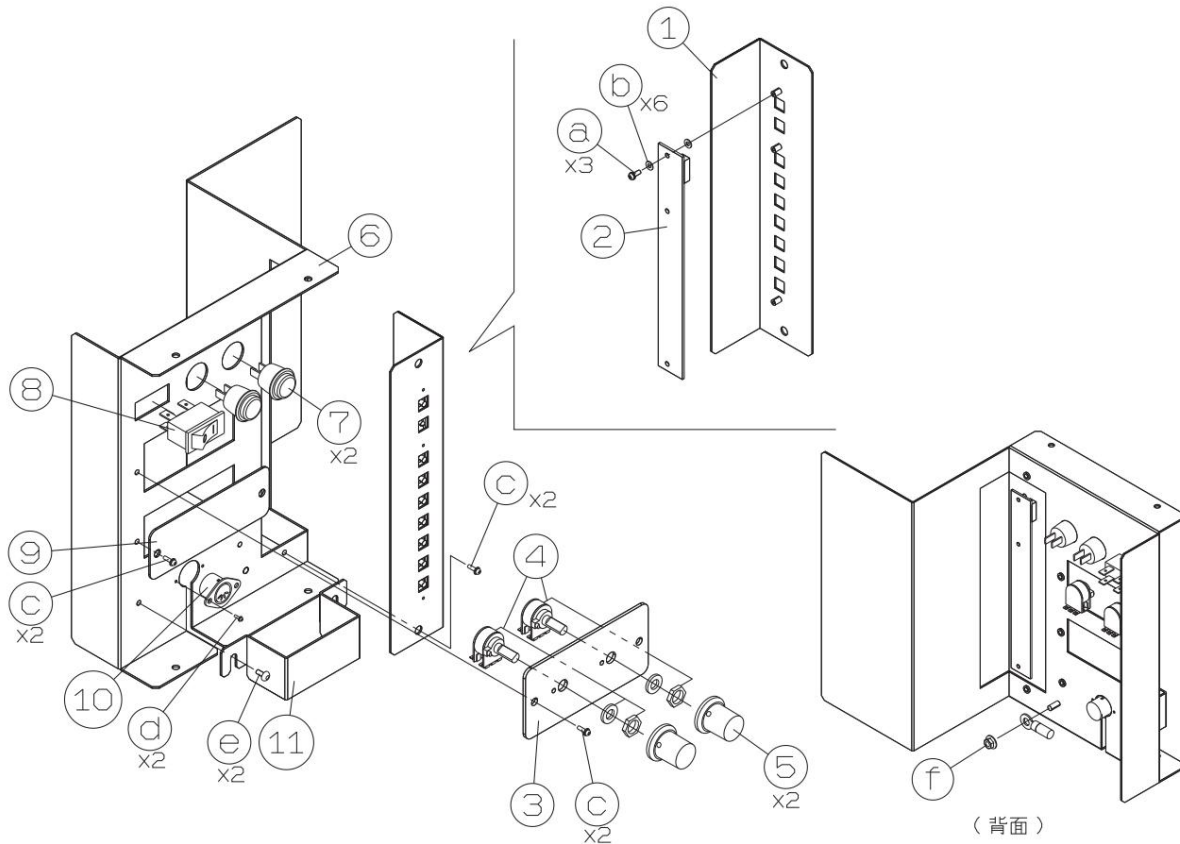

Assembly, Service

No.	Part Number	Product name	Model/Specification	Quantity	remarks
1	114640960000	PLATE,PCB(CTL)		1	
2		LCD SWITCH BOARD		1	114591390000 Accessories
3	114640950000	PLATE,VOLUME		1	
4	113535350000	WIRING HARNESS		1	
5	000314360000	KNOB		2	
6	114640970000	PLATE,SERVICE		1	
7	112470520000	SWITCH, PUSH		2	
8	110794730000	SWITCH, ROCKER		1	
9	000961480000	COVER,COUNTER		1	
10	113535360000	WIRING HARNESS		1	
11	112374220000	COVER,PLUG		1	

ASS'Y,SERVICE Screws and spare parts

No.	Model/Specifications	Quantity	remarks
	Product name a Washer assembled cross recessed pan head screw M2x8 SW,PW (No. 2 + polished round) 3 Chromate		
b	POM washer c	CC-0255-10	6 POM
	Washer assembled cross recessed pan head screw M4x10 SW,PW (No.2 + polished round) 6 Chromate		
d	Washer assembled cross recessed pan head screw M2x6 SW,PW (No. 2 + polished round) 2 Chromate		
e	Hexagon socket button bolt f	M4x10	2. Chrome
	Flange hexagon nut	M4	1 Chromate with serrations

The parts contents may vary depending on the shipping time.

Fig.12 Assembly, fan

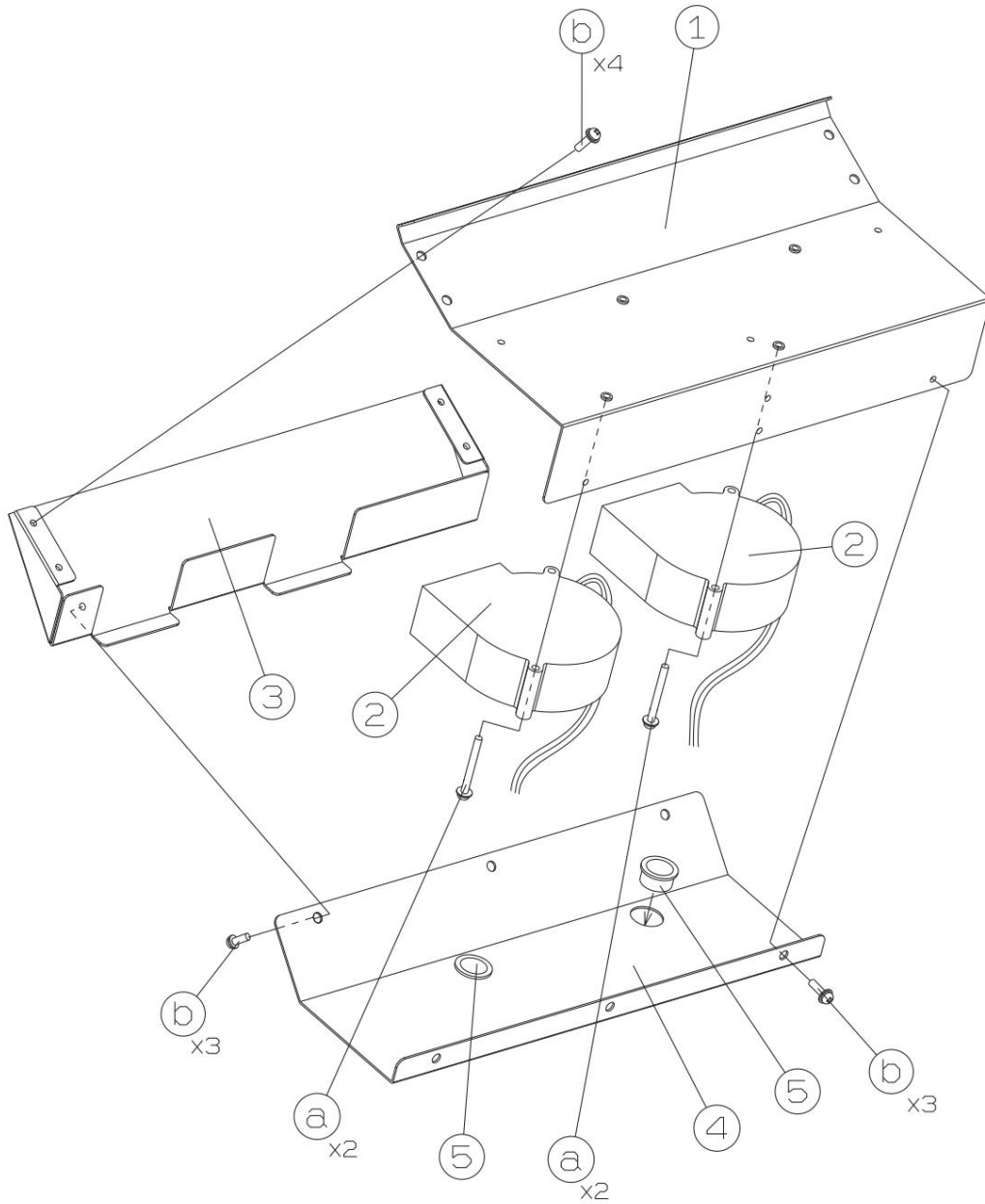

ASS'Y, FAN

No.	Part Number	Product name	Model/Specification	Quantity	remarks
1	112899770000	BRACKET, FAN		1	
2	112302610000	MOTOR, FAN		2	
3	112899780000	DUCT,LCD		1	
4	112899790000	COVER DUCT		1	
5	112358450000	BUSH		2	

Assembly, fan screws and spare parts

No.	Product	Model/Specifications	Quantity	remarks
a	Washer assembled cross recessed pan head screw M4x40 SW,PW (No. 2 + polished round) 4 Chromate			
b	Washer assembled cross recessed pan head screw M4x8 SW,PW (No. 2 + polished round) 10 Chromate			

The parts contents may vary depending on the shipping time.

Fig.13 Assembly, MAINTENANCE DOOR

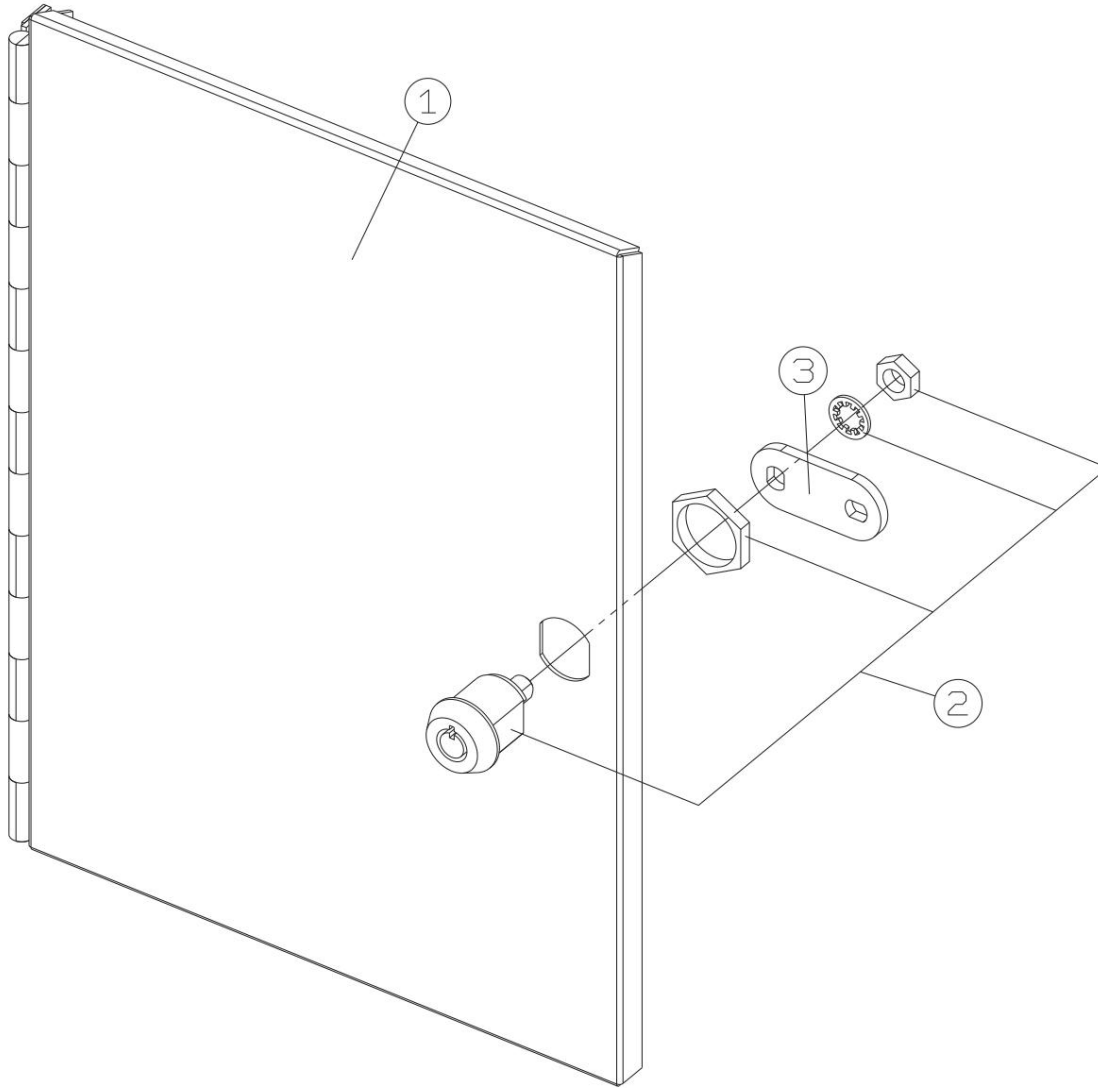

Assembly, Main Door

No.	Part Number	Product name	Model/Specifications	Quantity	Notes
1	112885340000	DOOR, MAINTENANCE		1	
2	000974240000	LOCK		1	2 keys + cylinder
3	002544330000	PLATE, LOCK		1	

The parts contents may vary depending on the shipping time.

Fig.14 Assembly, front panel

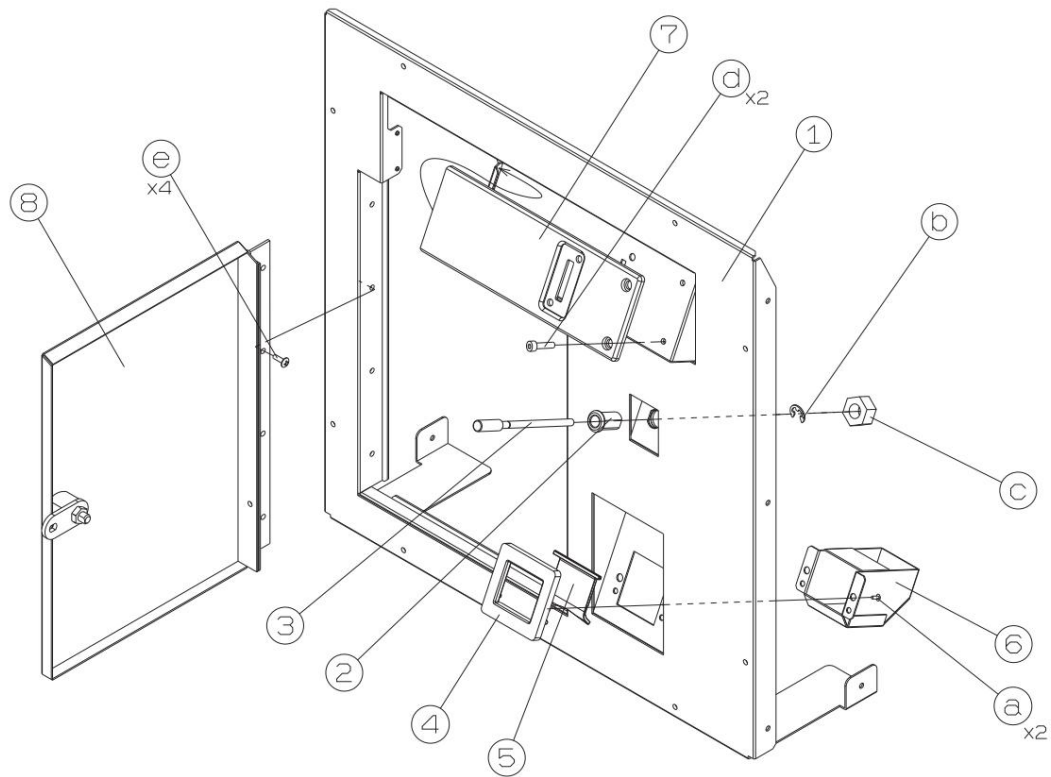

Assembly, front panel

No.	Part Number	Product name	Model/Specifications	Quantity	Notes
1	112883630000	PANEL, FRONT		1	
2	112374200000	GUIDE, BUTTON		1	
3	112374190000	BUTTON, RETURN		1	
4	111764190000	FRAME COIN CANCEL		1	
5	111492550000	COVER COIN CANCEL		1	
6	112373990000	BOX, RETURN		1	
7	112368430000	PANEL, ENTRY(R)		1	
8	112901060000	ASS'Y, MAINTE DOOR		1	See Fig. 13

Assembly, front panel screws and spare parts

No.	Product name	Model/Specifications	Remarks	Quantity	
a	Cross recessed binding head screw	M3x5		2	Chrome
b	E-type retaining ring	Call 3		1	Trivalent chromate
c	Hexagonal nut	M12	Type 1/Regular	1	Chrome
d	Hexagonal socket bolt	M4x10		2	Chrome
e	Cross recessed truss head screw	M4x10		4	Black chromate

The parts contents may vary depending on the shipping time.

Fig.15 UNIT, IC CARD

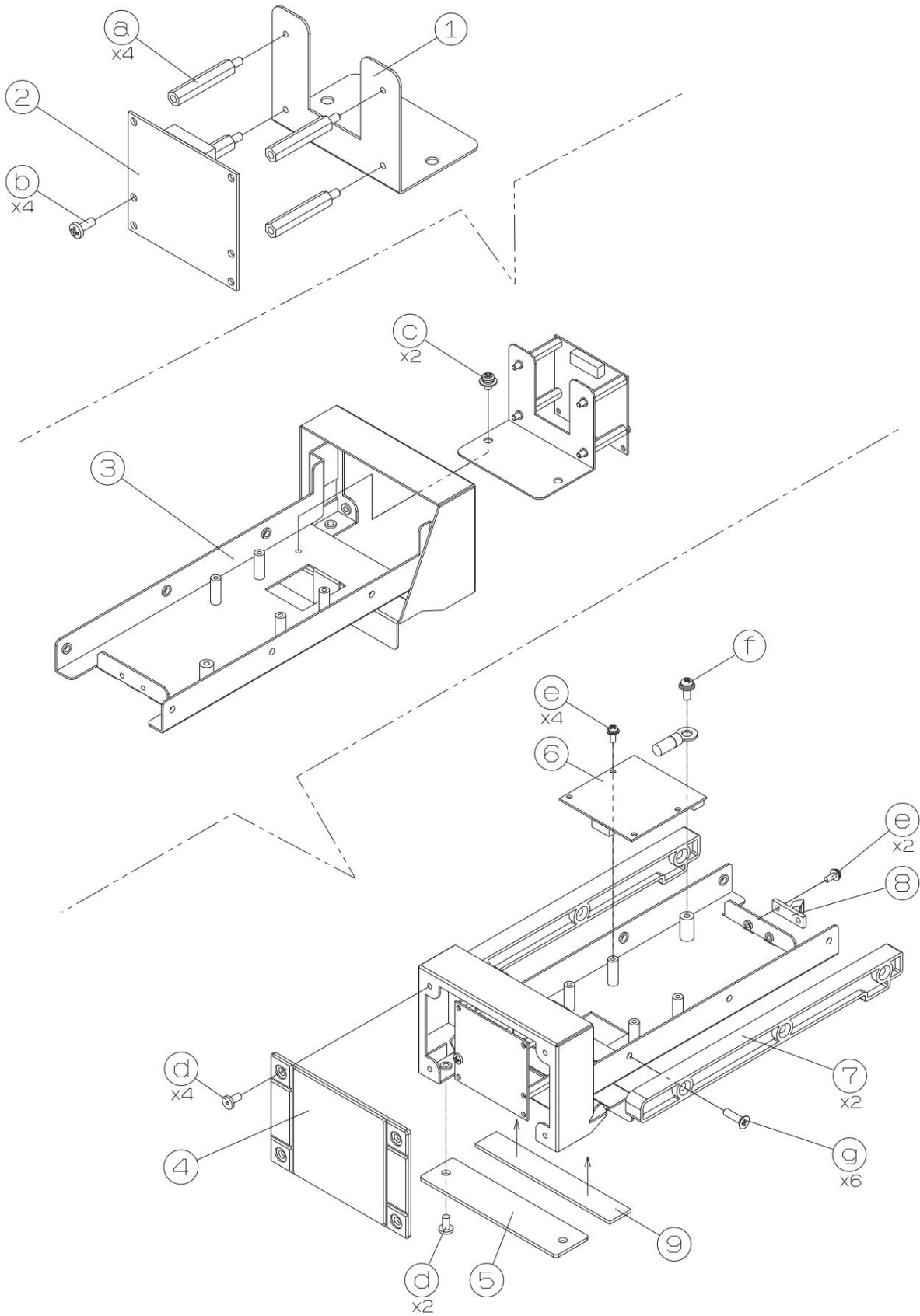

UNIT,IC CARD

No.	Part Number	Product name	Model/Specification	Quantity	remarks
1	114197130000	BRACKET, PCB		1	
2	113547950000	#PCB UNIT		1	
3	114197110000	BASE, PCB		1	
4	114197190000	PANEL, PCB		1	
5	114197200000	PANEL, PCB(BT)		1	
6	113547940000	#PCB UNIT		1	
7	114382020000	RAIL		2	
8	112330290000	CATCH		1	
9	114289110000	TAPE, SPONGE(IC)		1	

UNIT,IC CARD Screws and spare parts

No.	Product name	Model/Specifications	Quantity	remarks
a	Hexagonal	BS-330WE	4	
b	POM spacer Cross recessed blind head screw	4 Trivalent chromate M3x8		
c	Washer assembled cross recessed pan head screw	M4x6 SW,PW (No. 2 + polished round) 2 Trivalent chromate		
d	Hexagon socket extra low head	M4x8	6 Trivalent black chromate	
e	Washer assembled cross recessed pan head screw	M3x8 SW,PW (No. 2 + polished round) 6 Trivalent chromate		
f	Washer assembled cross recessed pan head screw	M4x10 SW,PW (No.2 + polished round) 1 Trivalent chromate		
g	Cross recessed flat head screw	6 Trivalent chromate M4x15		

The parts contents may vary depending on the shipping time.

Fig.16 Assembly, LCD

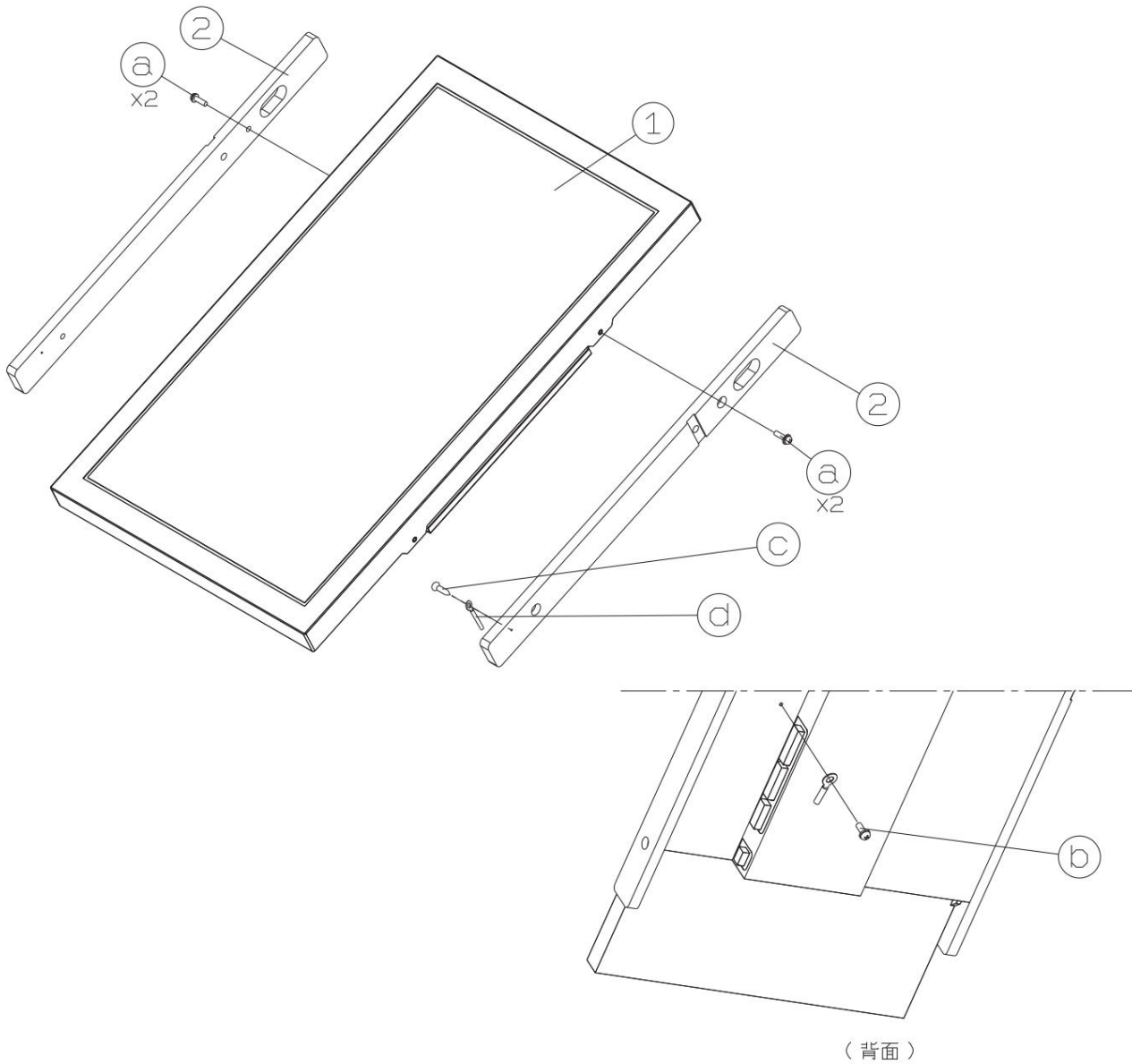

Assembly, LCD

No.	Part Number	Product name	Model/Specification	Quantity	remarks
1	114591390000	LCD, TFT		1	
2	112441260000	BRACKET, LCD		2	

Assembly, LCD screws and spare parts

No.	Model/Specifications	Quantity	remarks
a	Washer assembled cross recessed pan head screw M4x20 SW,PW (No. 2 + polished round) 4 Chromate	4	
b	Washer assembled cross recessed pan head screw M4x8 SW,PW (No. 2 + polished round) 1 Chromate	1	
c	Cross recessed round wood screw 1 Chromated	Call 3.1x8	
d	Splicing Clip	CS-7 (ÿ4.4 L76)	1

The parts contents may vary depending on the shipping time.

Fig.17 ASS'Y, COVER (B)

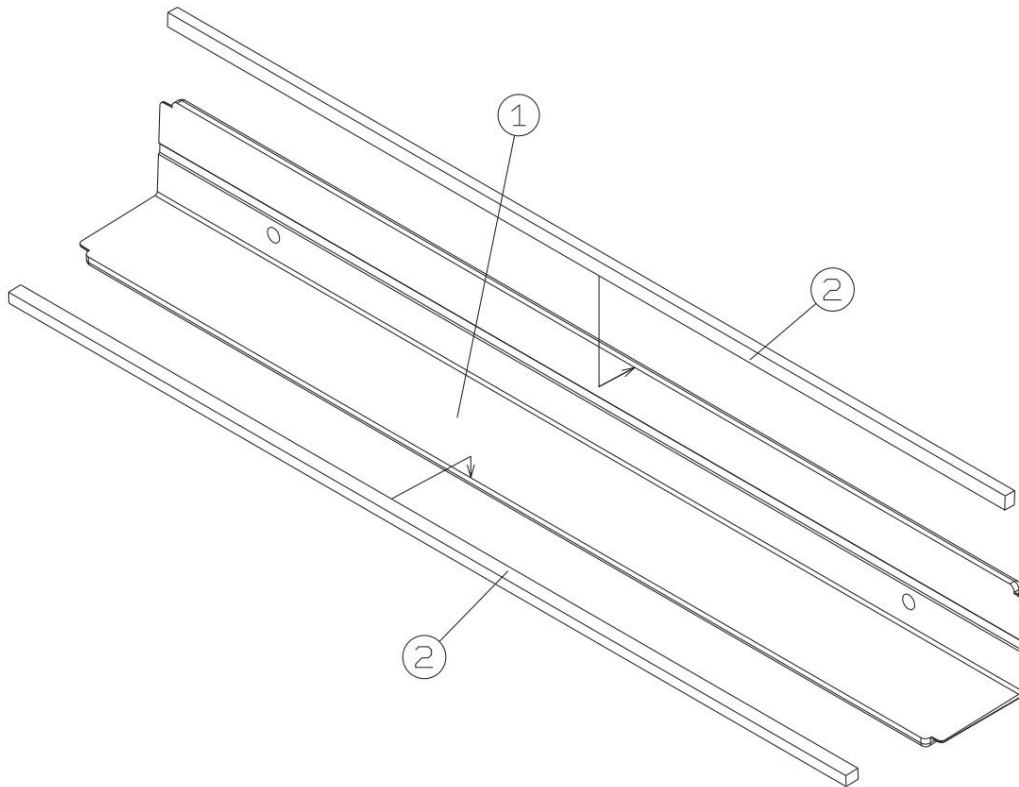

ASS'Y, COVER(B)

No.	Part Number	Product name	Model/Specification	Quantity	remarks
1	112317190000 COVER	CUBE(B)		1	
2	112368570000 TAPE,SPONGE	(C)		2	

The parts contents may vary depending on the shipping time.

Fig.18 ASS'Y, COVER (ATL)

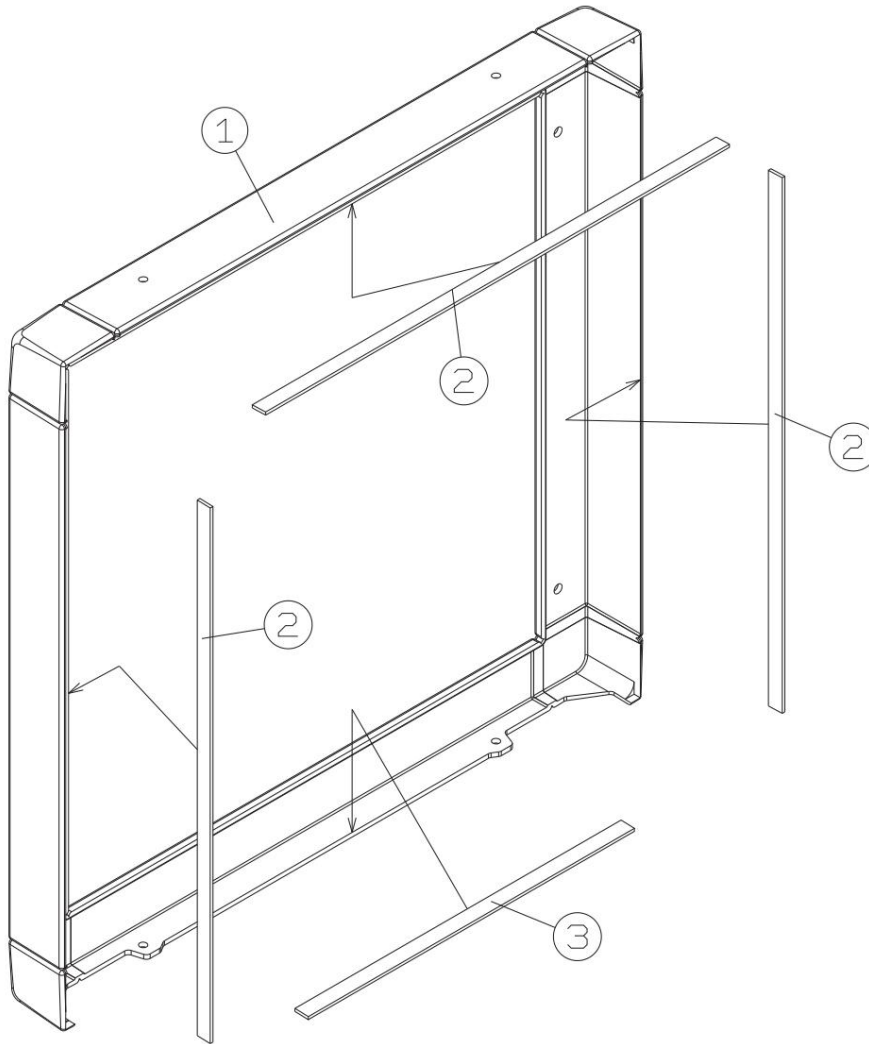

ASS'Y, COVER (ATL)

No.	Part Number	Product name	Model/Specification	Quantity	remarks
1	112357610000 COVER	CUBE(ATL)		1	
2	112368550000 TAPE,SPONGE(A)			3	
3	112368560000 TAPE,SPONGE(B)			1	

The parts contents may vary depending on the shipping time.

Fig.19 ASS'Y, COVER (ATR)

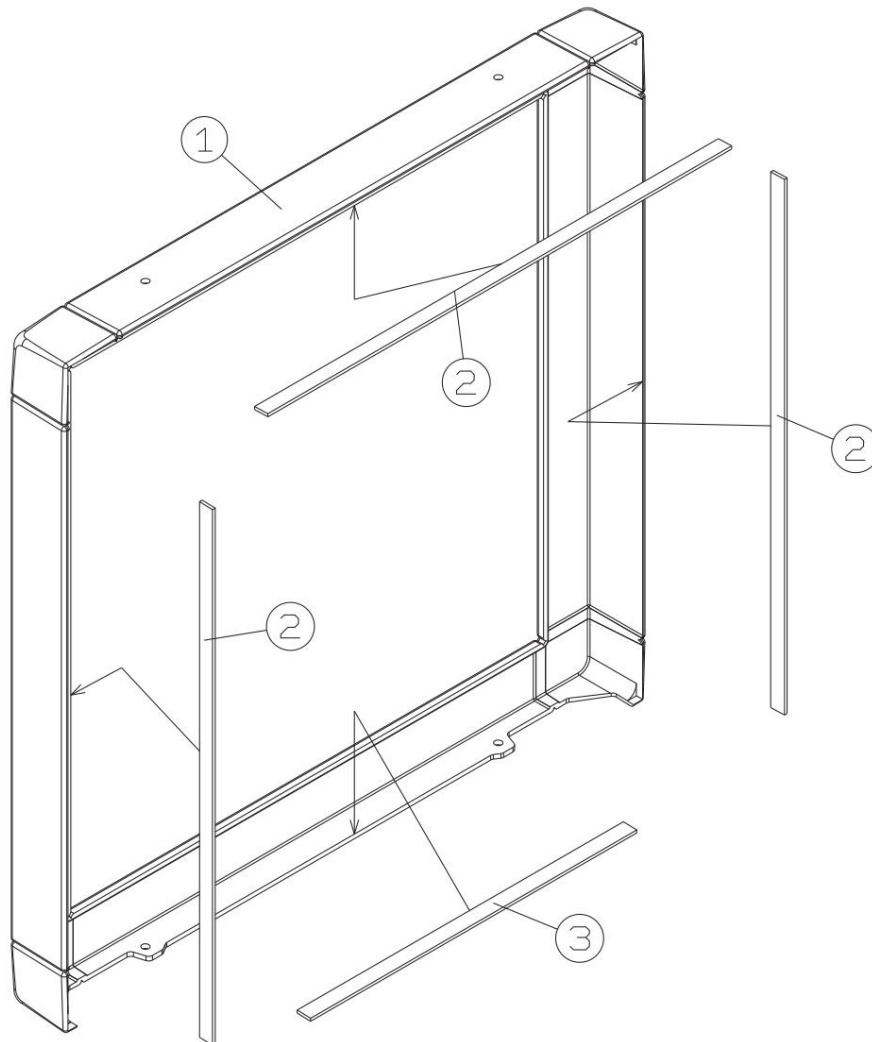

Assembly, Cover (ATR)

No.	Part Number	Product name	Model/Specification	Quantity	remarks
1	112357620000	COVER,CUBE(ATR)		1	
2	112368550000	TAPE,SPONGE(A)		3	
3	112368560000	TAPE,SPONGE(B)		1	

The parts contents may vary depending on the shipping time.

Fig.20 Assembly, board PCB

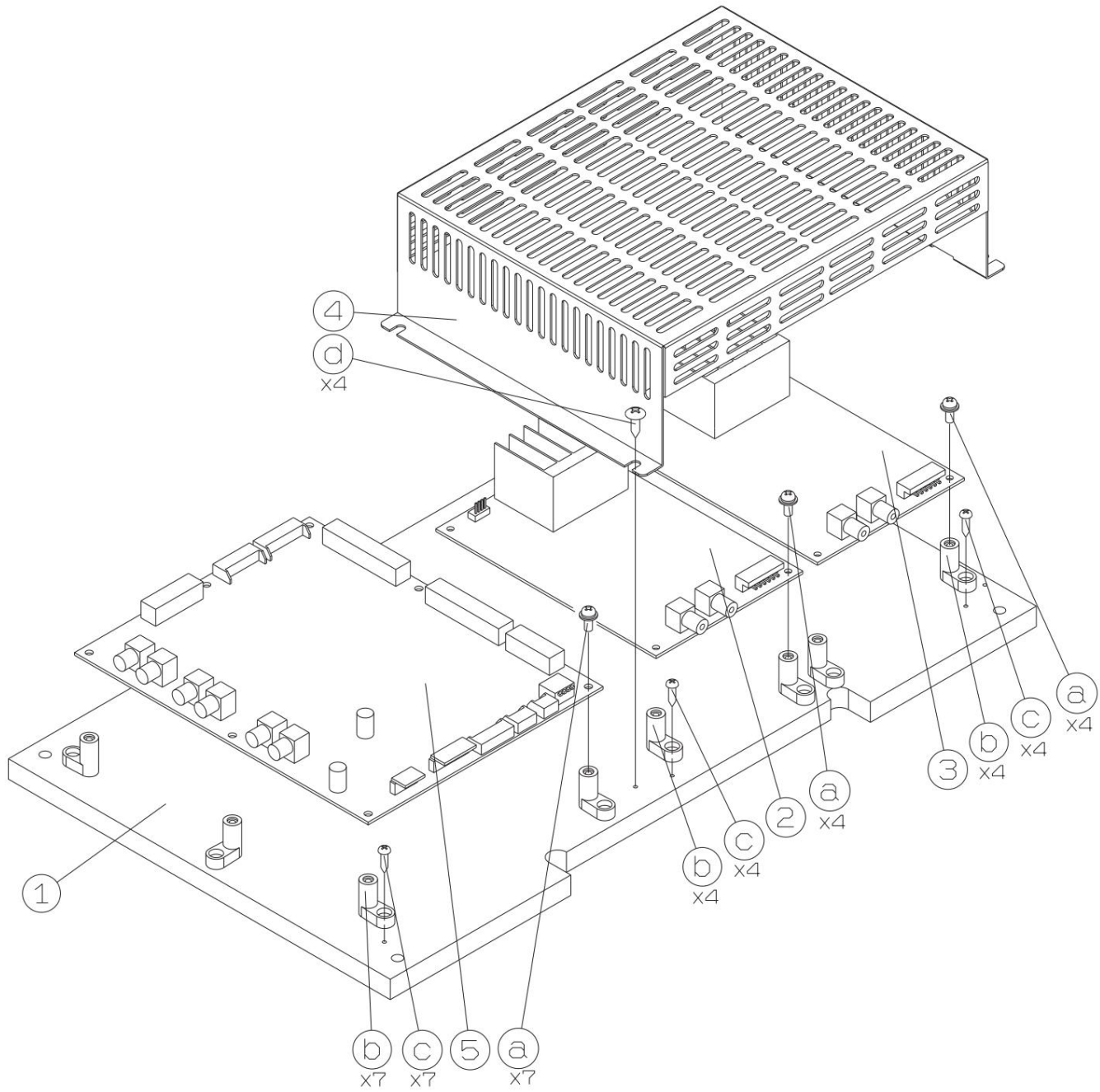

Assembly, Board, PCB

No.	Part Number	Product name	Model/Specification	Quantity	Remarks
1	112373650000	BOARD,PCB		1	
2	113135780000	AMP (FULL)		1	
3	113200150000	AMP (WOOFER)		1	
4	112899810000	COVER,PCB		1	
5	114645760000	UNIT,PCB(B)		1	

ASS'Y, BOARD PCB Screws and auxiliary materials

No.	Product name	Model/Specifications	Quantity	remarks
a.	Washer assembled cross recessed pan	head screw M3x8 SW,PW (No. 2 + polished round)	15	Chromate
b.	Lock spacer	LL-2	15	
c.	Cross recessed round wood screw	Call 3.1x13	15	Chromate
d.	Cross recessed truss tapping screw	Call 3.5x12 (1 type)	4	Chromate

The parts contents may vary depending on the shipping time.

Fig.21 Assembly, FAN PANEL

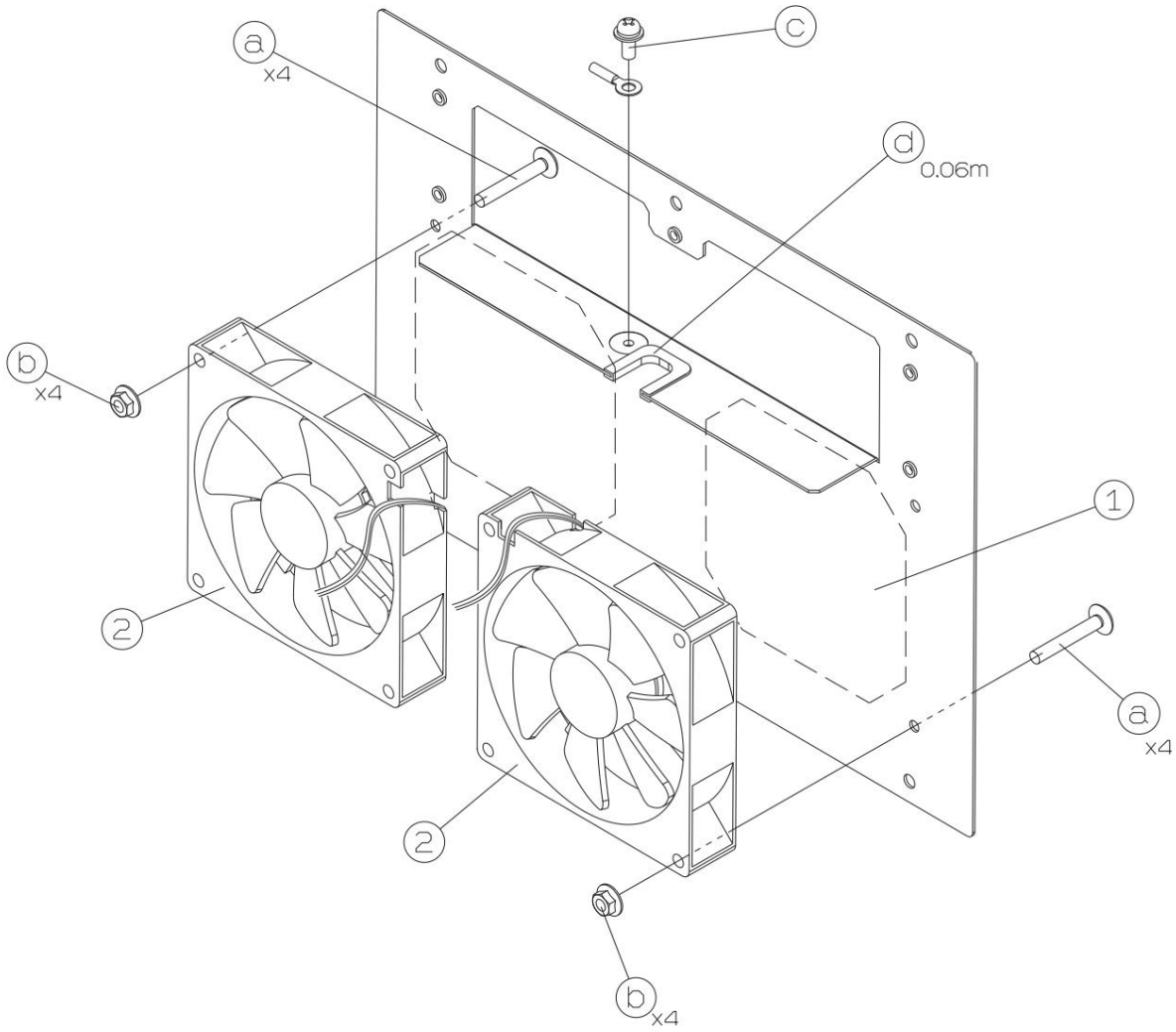

Assembly, Fan Panel

No.	Part Number	Product name	Model/Specification	Quantity	remarks
1	112899750000	PANEL, DUCT		1	
2	112302600000	MOTOR, FAN		2	

Assembly, fan panel screws and spare parts

No.	Product name	Model/Specifications	Quantity	remarks
a	Cross recessed truss head screw	M4x35	8	Black chromate
b	Flange hexagonal nut	M4	8	Chromate with serrations
c	Washer assembled cross recessed pan head screw M4x10 SW,PW (No. 2 + polished round)		1	Chromate
d	Free bush	KG-012-2	0.06m	

The parts contents may vary depending on the shipping time.

Fig.22 Assembly, speaker box

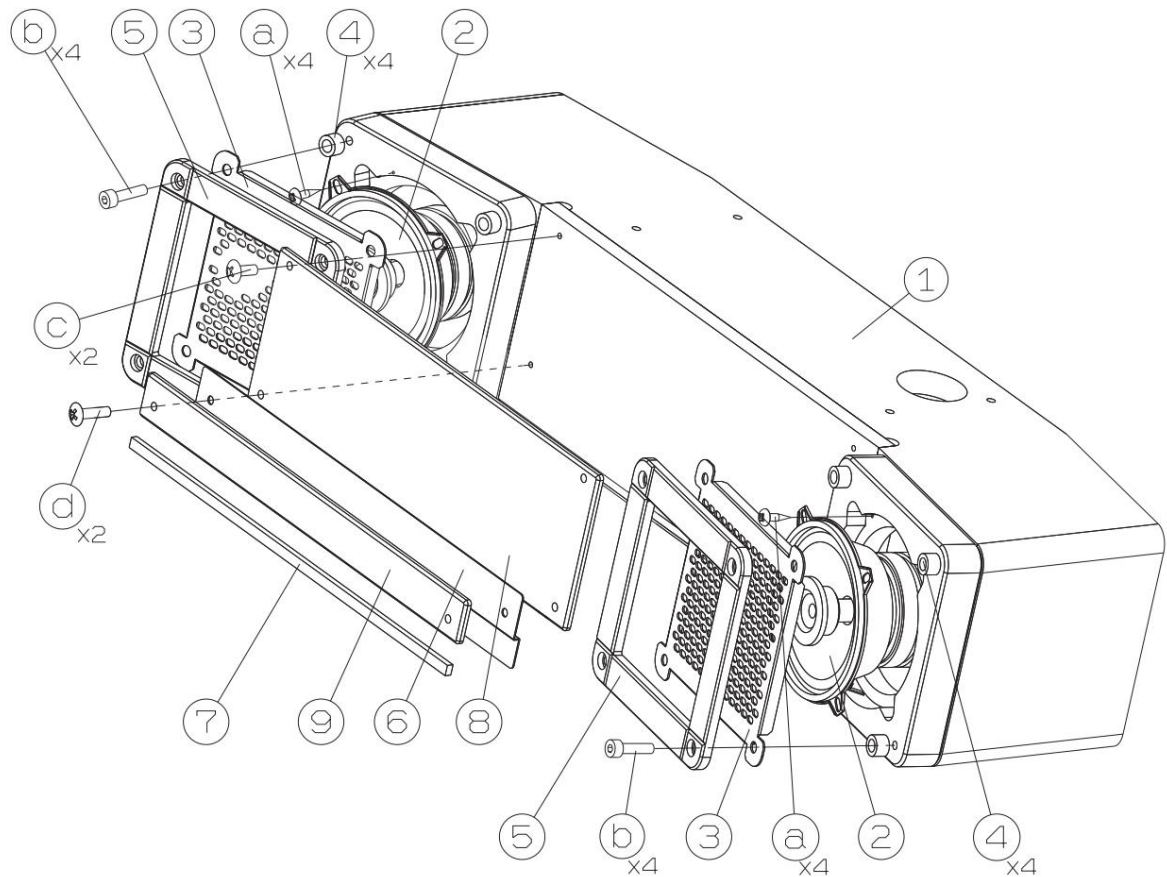

Assembly, speaker box

No.	Part Number	Product name	Model/Specification	Quantity	remarks
1	112373600000	BOX, SPEAKER		1	
2	113263040000	SPEAKER		2	
3	112899820000	COVER, SPEAKER		2	
4	112368530000	SPACER		8	
5	112368390000	COVER, SPEAKER		2	
6	112374130000	BRACKET, PANEL		1	
7	112368580000	TAPE, SPONGE(D)		1	
8	114628680000	PANEL, CENTER		1	Assembly, not included in speaker box
9	113253720000	PANEL, EMBLEM		1	Assembly, not included in speaker box

Assembly, Speaker Box, Screws and spare parts

No.	Product name	Model/Specification	Quantity	remarks
	a Cross recessed truss tapping	Call 4x15 (1 type)	8	Black chromate
	screw b Hexagon socket head	M6x45	8	Chromium
	bolt c Cross recessed truss machine	M4x20	2	Chrome
	screw d Cross recessed truss machine screw	M4x30	2	Chrome

The parts contents may vary depending on the shipping time.

Fig.23 Assembly, cube frame

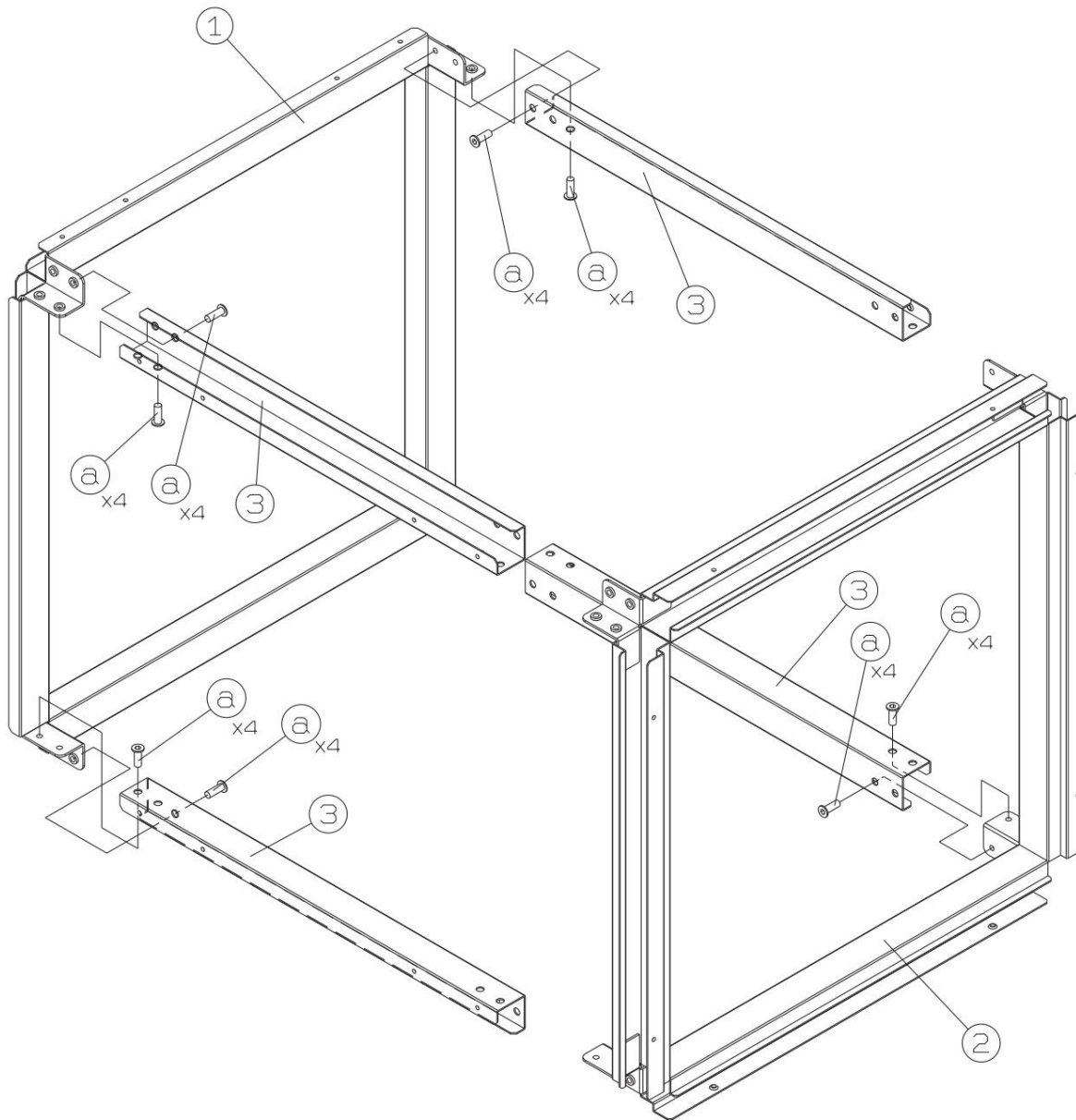

Assembly, cube frame

No.	Part Number	Product name	Model/Specification	Quantity	remarks
1	112883640000	FRAME,CUBE(A)		1	
2	112883650000	FRAME,CUBE(B)		1	
3	114223560000	FRAME,CUBE(C)		4	

ASS'Y, CUBE FRAME Screws and spare parts

No.		Model/Specifications	Quantity	remarks
	Product name: Hexagon socket extra low head bolt	M4x10	32	Black chromate

The parts contents may vary depending on the shipping time.

Fig.24 ASS'Y, LED FRAME (A)

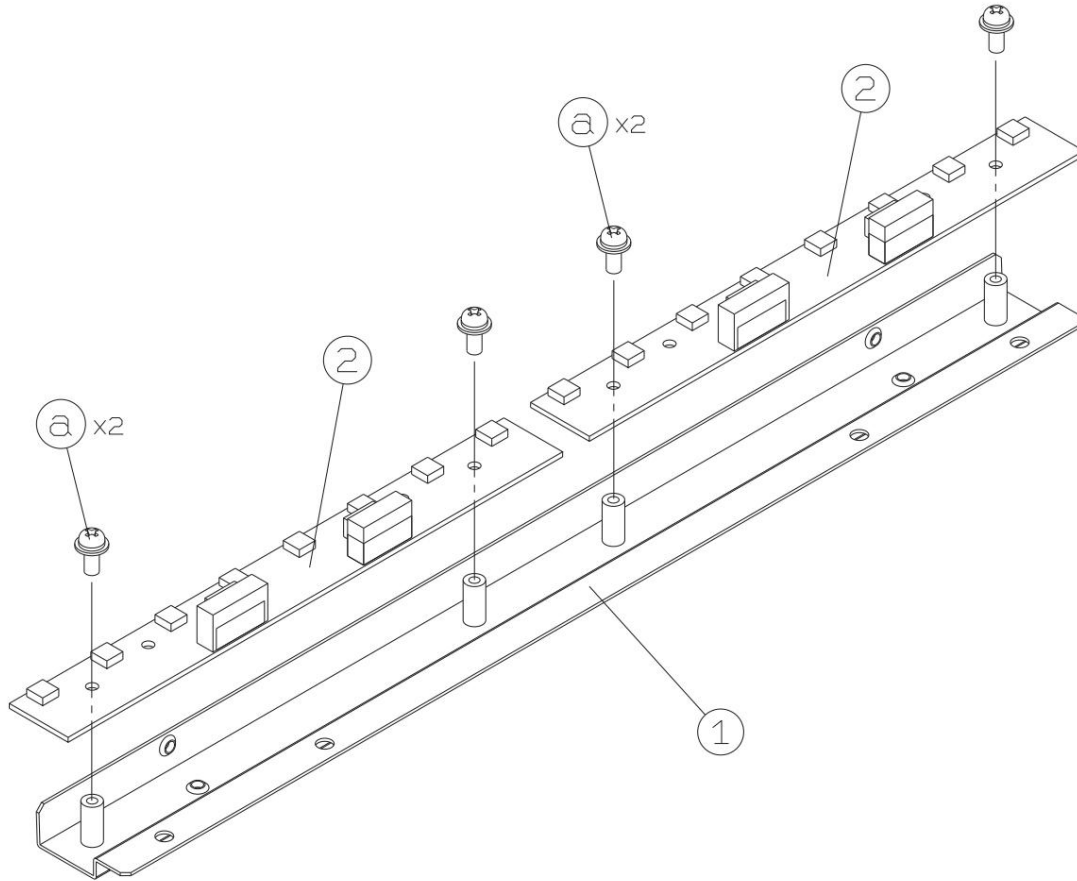

Assembly, LED frame (A)

No.	Part Number	Product name	Model/Specification	Quantity	remarks
1	112883690000	BRACKET, LED(A)		1	
2	114659100000	UNIT, PCB(C)		2	

Assembly, LED FRAME (A) Screws and spare parts

No.	Product name	Model/Specifications	Remarks	Quantity	Chromate
	a Washer assembled cross recessed pan head screw M3x8 SW,PW (No. 2 + polished round)			1	

The parts contents may vary depending on the shipping time.

Fig.25 ASS'Y, LED FRAME (B)

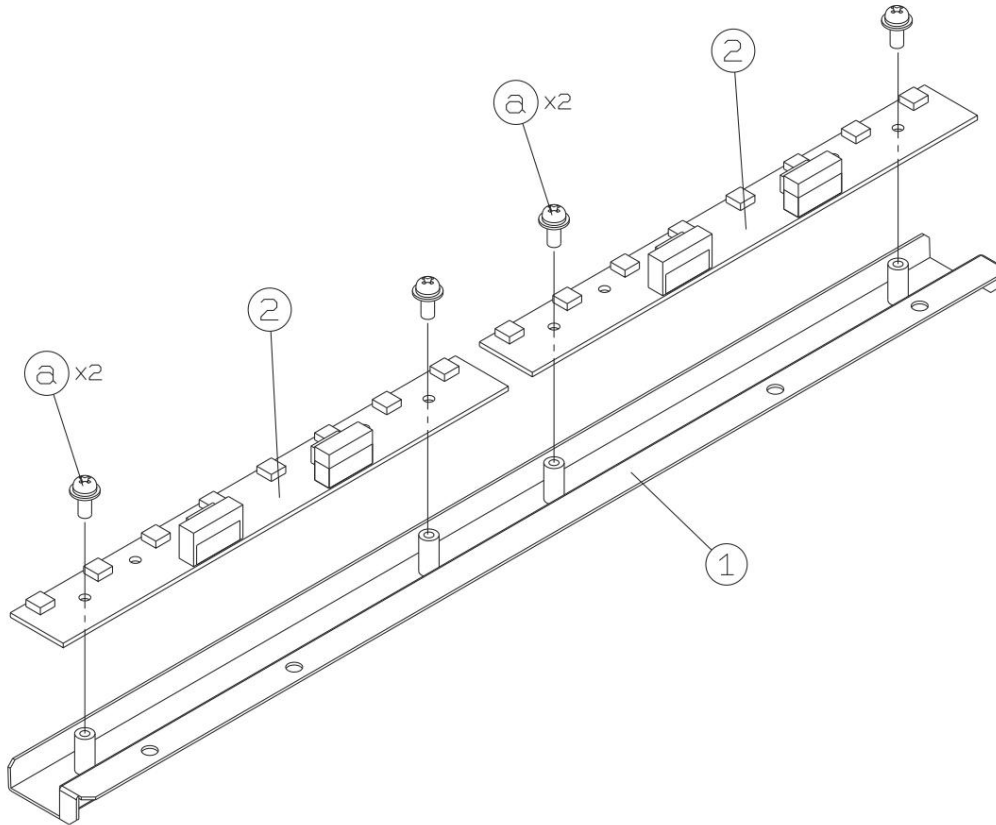

Assembly, LED frame (B)

No.	Part Number	Product name	Model/Specification	Quantity	remarks
1	112883700000	BRACKET, LED(B)		1	
2	114659100000	UNIT, PCB(C)		2	

ASS'Y, LED FRAME (B) Screws and auxiliary materials

No.	Model/Specifications	Remarks	Quantity
	Product name a Washer assembled cross recessed pan head screw M3x8 SW,PW (No. 2 + polished round) 4 Chromate		

The parts contents may vary depending on the shipping time.

Fig.26 ASS'Y, LED FRAME (C)

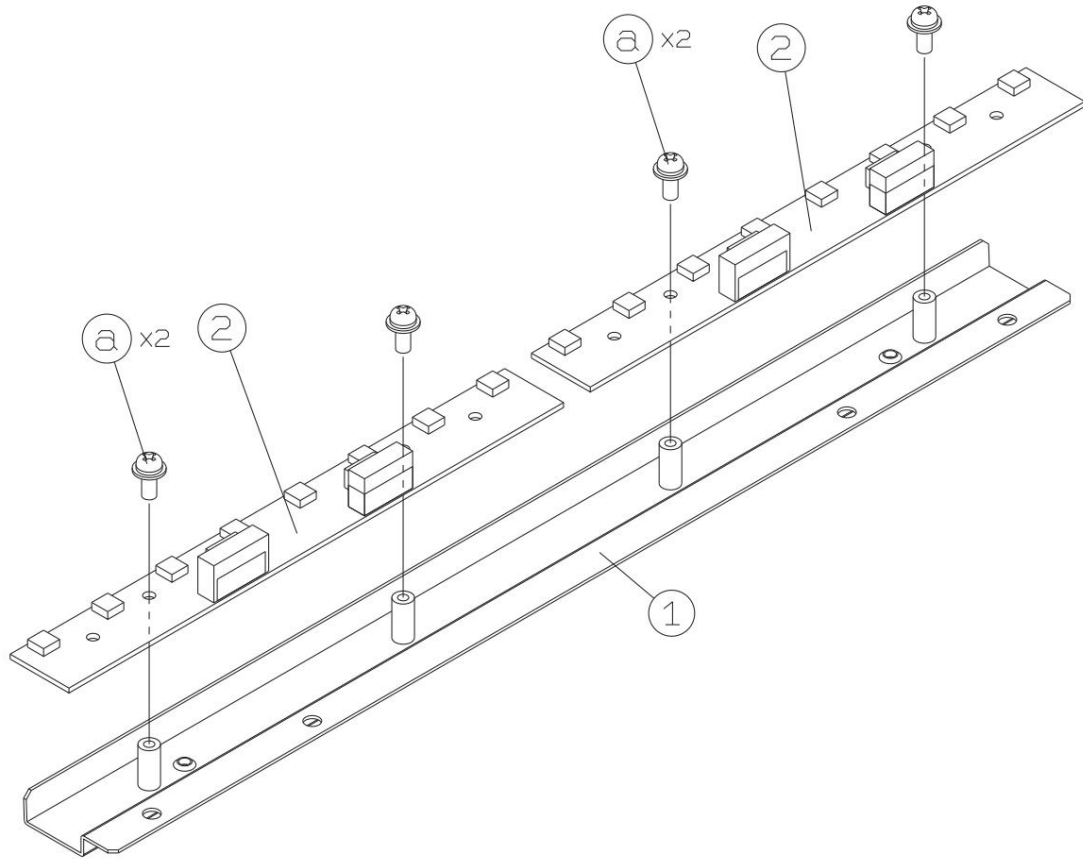

Assembly, LED frame (C)

No.	Part Number	Product name	Model/Specification	Quantity	remarks
1	112885310000	BRACKET, LED(C)		1	
2	114659100000	UNIT, PCB(C)		2	

ASS'Y, LED FRAME(C) Screws and auxiliary materials

No.	Model/Specifications	Remarks	Quantity
	Product name a Washer assembled cross recessed pan head screw M3x8 SW,PW (No. 2 + polished round)		4 Chromate

The parts contents may vary depending on the shipping time.

Fig.27 ASS'Y, COVER (BT)

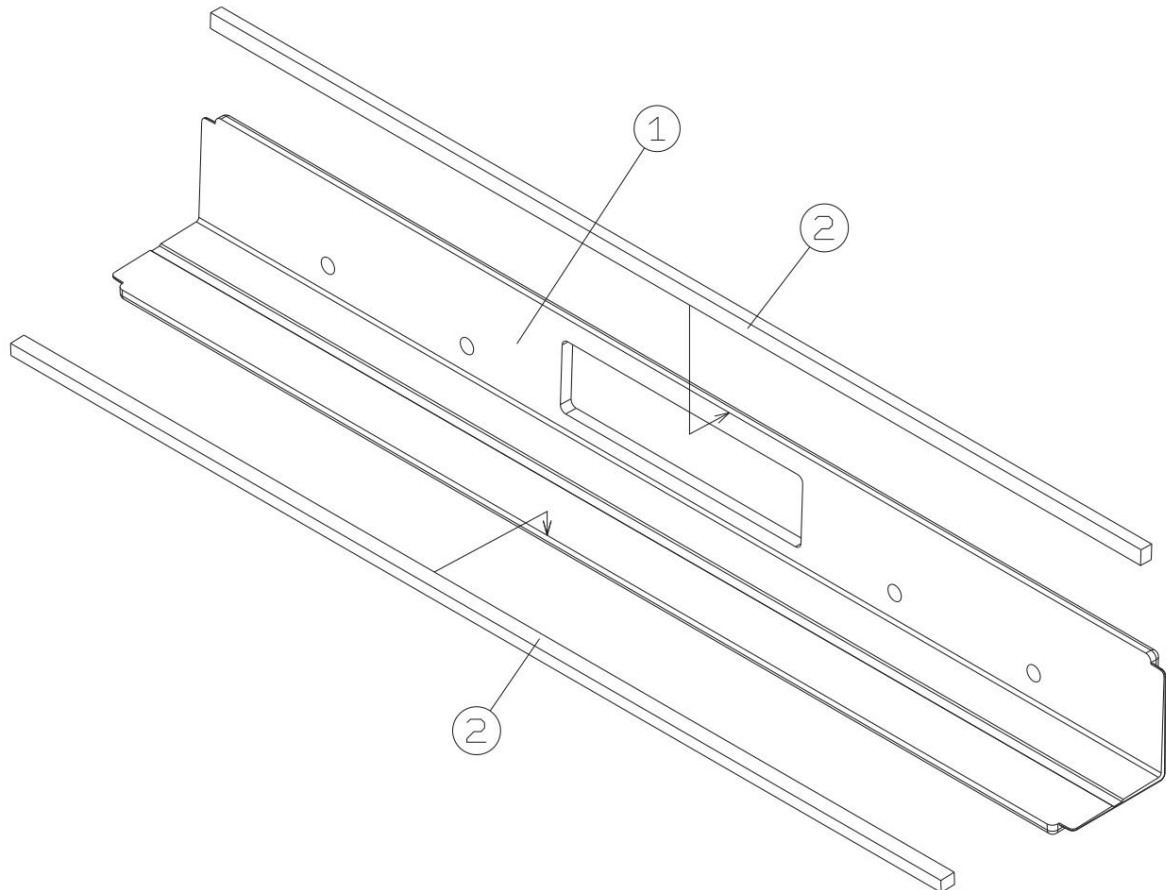

ASS'Y, COVER (BT)

No.	Part Number	Product name	Model/Specification	Quantity	remarks
1	112317200000 COVER	CUBE(BT)		1	
2	112368570000 TAPE,S	PONGE(C)		2	

The parts contents may vary depending on the shipping time.

Fig.28 ASS'Y, COVER (A)

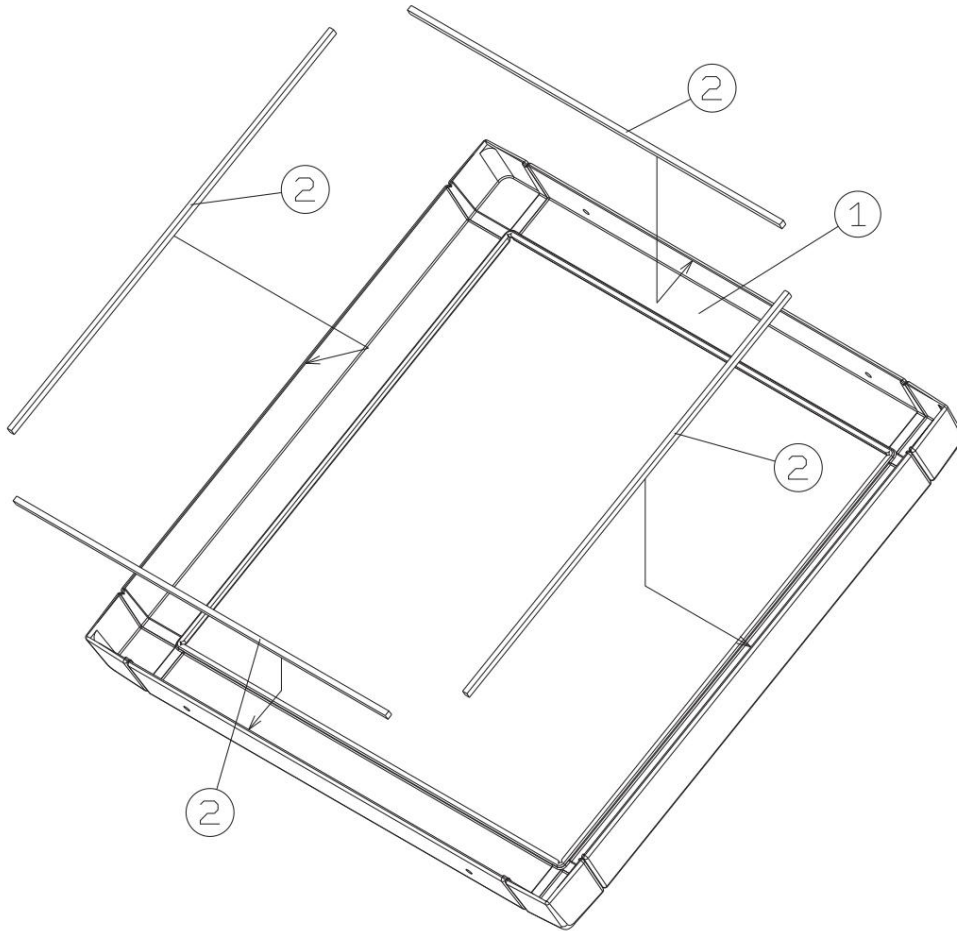

ASS'Y, COVER(A)

No.	Part Number	Product name	Model/Specification	Quantity	remarks
1	112317150000 COVER	CUBE(A)		1	
2	112368570000 TAPE,SPONGE	(C)		4	

The parts contents may vary depending on the shipping time.

Fig.29 ASS'Y, COVER (AP)

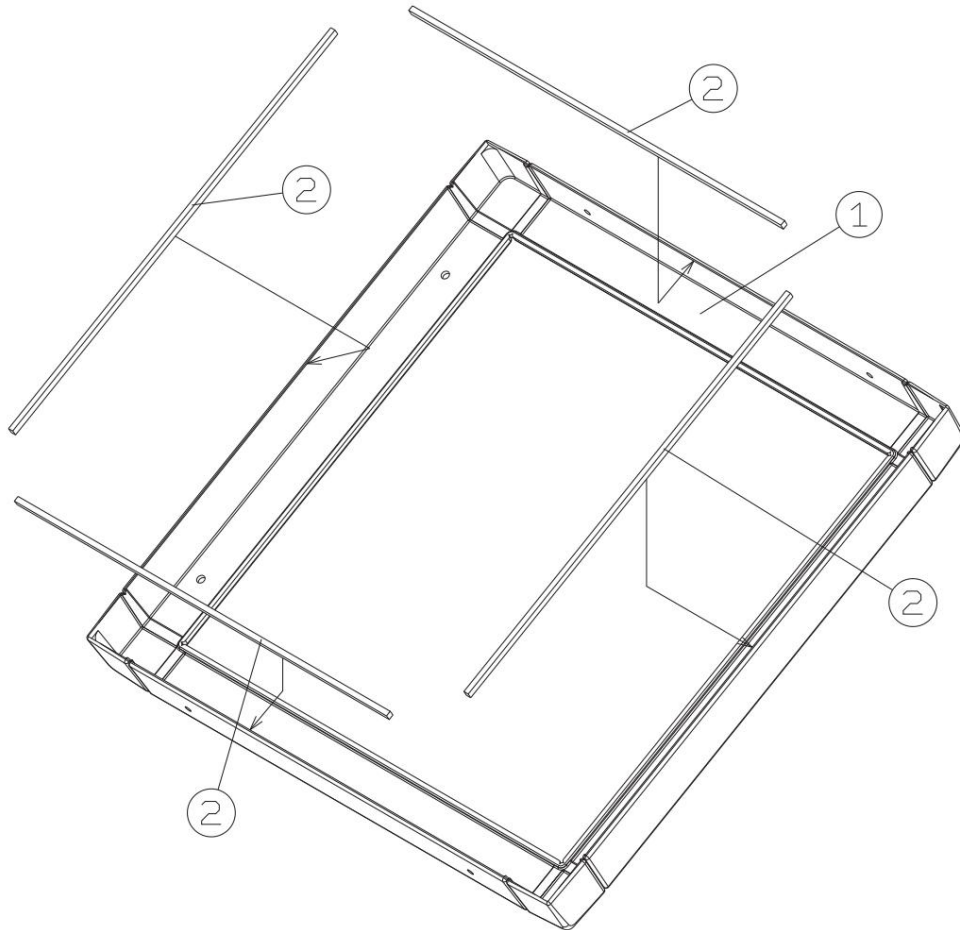

ASS'Y, COVER (AP)

No.	Part Number	Product name	Model/Specification	Quantity	remarks
1	112317160000 COVER	CUBE(AP)		1	
2	112368570000 TAPE,S	PONGE(C)		4	

The parts contents may vary depending on the shipping time.

Fig.30 UNIT, TITLE (1/2)

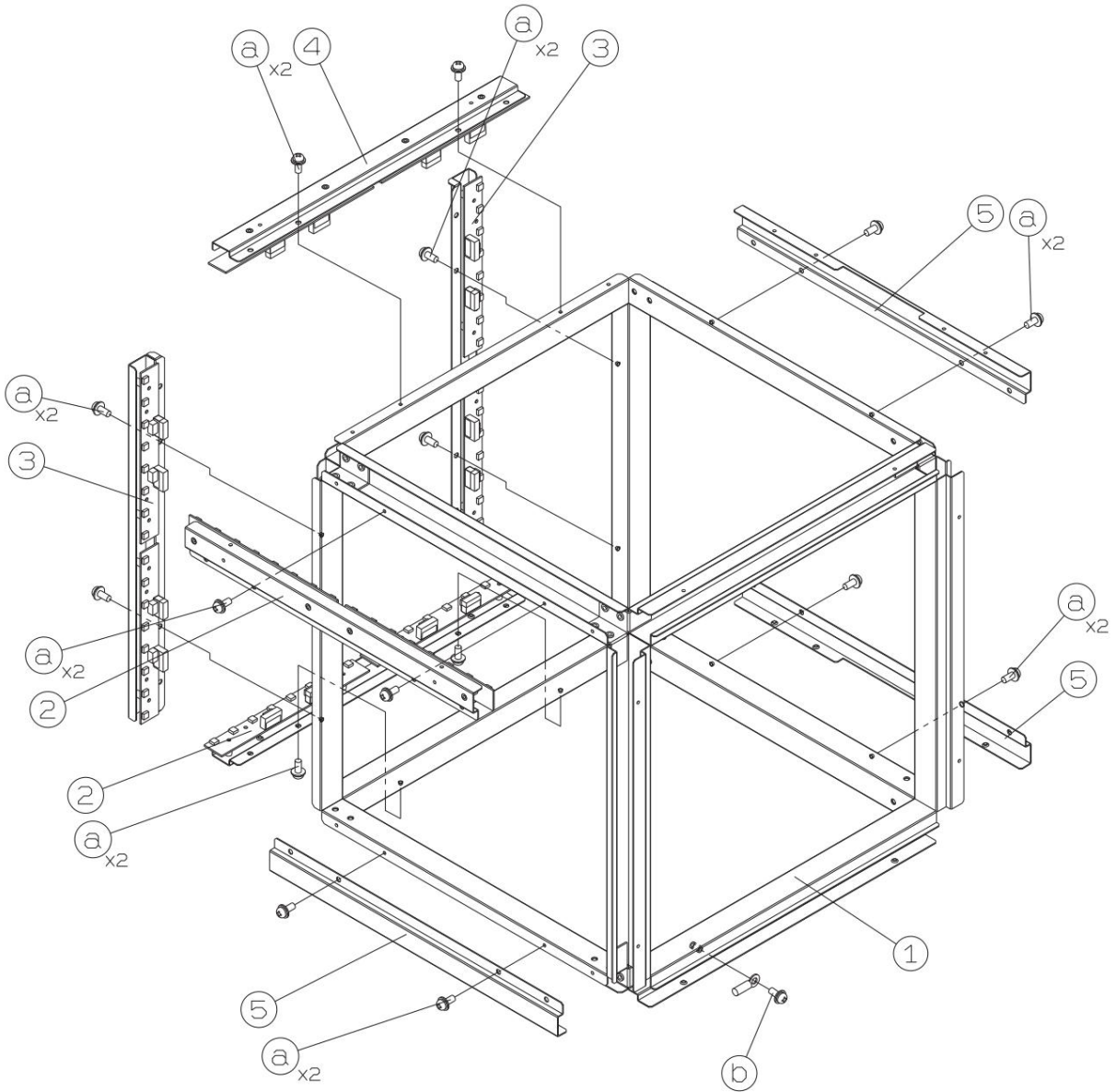

UNIT, TITLE(1/2)

No.	Part Number	Product name	Model/Specification	Quantity	remarks
1	114278430000 ASS'Y	CUBE FRAME		1	See Fig.23
2	114659860000 ASS'Y	LED FRAME(A)		2	See Fig.24
3	114659870000 ASS'Y	LED FRAME(B)		2	See Fig.25
4	114659890000 ASS'Y	LED FRAME(C)		1	See Fig.26
5	112883680000 FRAME,	CUBE(D)		3	

UNIT, TITLE(1/2) Screws and spare parts

No.	Product name	Model/	Quantity	remarks
a	Specifications a Pan head screw with assembled washer	M4x8 SW, PW (No. 2 + small round)	16	Black chromate
b	Pan head screw with assembled washer	M4x10 SW, PW (No. 2 + polished round)	1	Chromate

The parts contents may vary depending on the shipping time.

Fig.31 UNIT, TITLE (2/2)

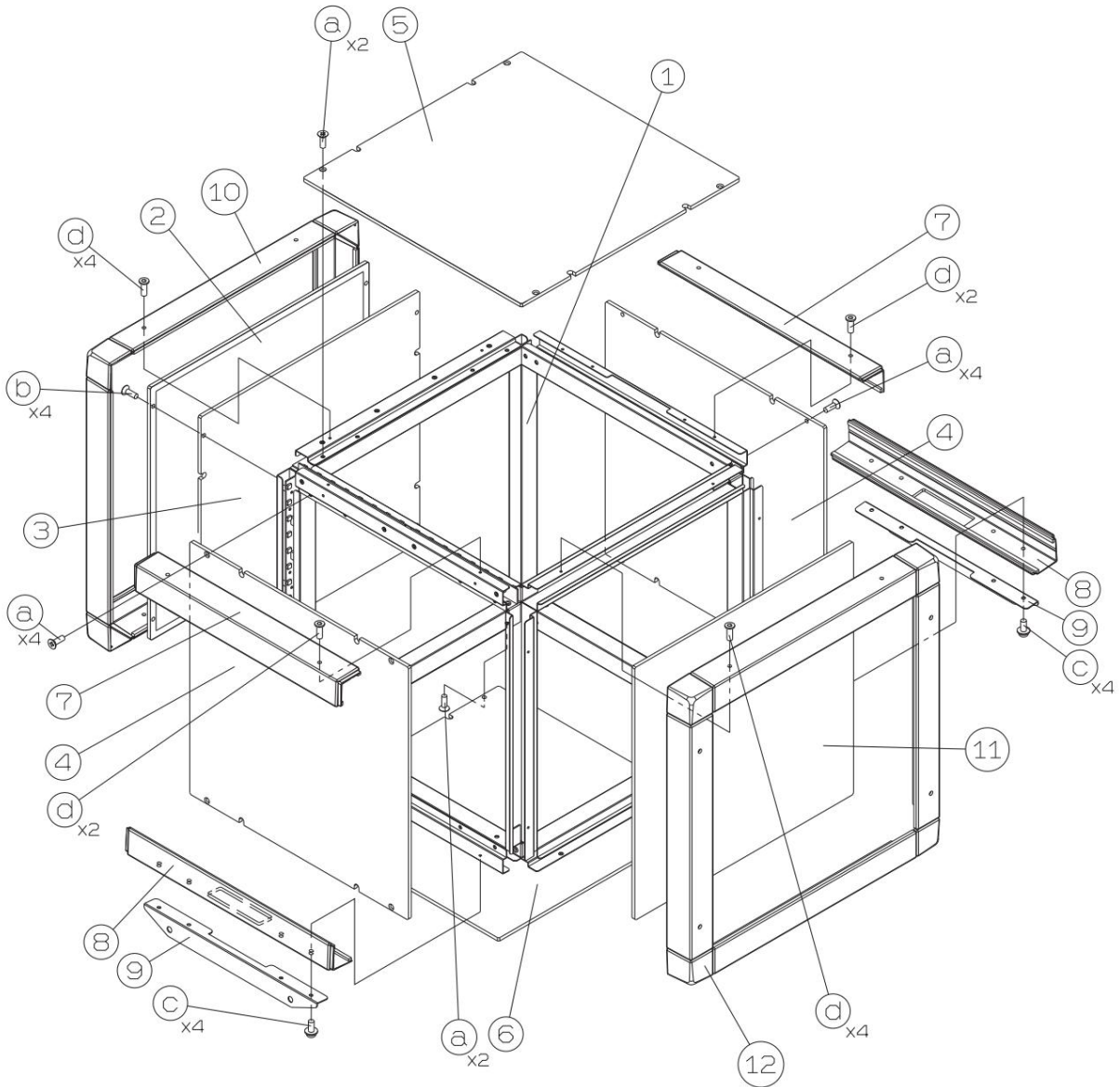

UNIT, TITLE(2/2)

No.	Part Number	Product name	Model/Specification	Quantity	remarks
1		UNIT, TITLE(1/2)		1	See Fig. 30
2	112368440000	PANEL TITLE		1	
3	112368450000	PANEL FRONT		1	
4	112368460000	PANEL SIDE		2	
5	112368470000	PANEL CEILING		1	
6	112368480000	PANEL BOTTOM		1	
7	112374660000	ASS'Y, COVER(B)		2	See Fig. 17
8	112374810000	ASS'Y, COVER(BT)		2	See Fig.27
9	112885320000	BRACKET,CUBE		2	
10	112374820000	ASS'Y,COVER(A)		1	See Fig.28
11	112368490000	PANEL BACK		1	
12	112374830000	ASS'Y,COVER(AP)		1	See Fig.29

UNIT, TITLE(2/2) Screws and spare parts

No.	Item Name	Quantity	Model/Specifications	Quantity	remarks
a	Phillips head countersunk head screw	12	Chromate M4x10		
b	Cross recessed flat head screw	4	Chromated M4x15		
c	Washer assembled cross recessed pan head screw	8	Chromate M4x15 SW,PW (No.2 + polished round)		
d	Hexagon socket extra low head bolt		M4x10	12	Black chromate

The parts contents may vary depending on the shipping time.

Fig.32 Assembly, COIN BASE

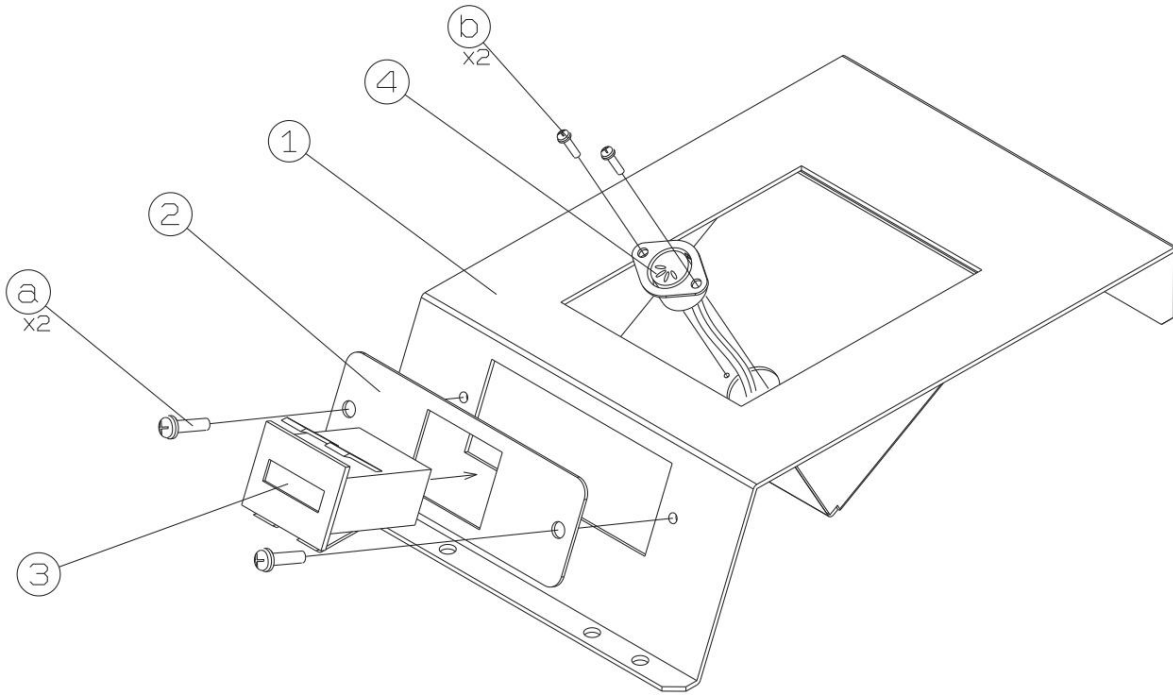

ASS'Y COIN BASE

No.	Part Number	Product name	Model/Specification	Quantity	remarks
1	111716650000	BASE, COIN BOX		1	
2	000961470000	BRACKET,COUNTER		1	
3	001100500000	COUNTER		1	
4	113535370000	WIRING HARNESS		1	

ASS'Y, COIN BASE Screws and spare parts

No.	Product name	Model/Specifications	Quantity	remarks
a	Washer assembled cross recessed pan head screw M4x10 SW,PW (No. 2 + polished round) 2 Chromate			
b	Washer assembled cross recessed pan head screw M2x6 SW,PW (No. 2 + polished round) 2 Chromate			

The parts contents may vary depending on the shipping time.

Fig.33 Assembly, USB SLOT

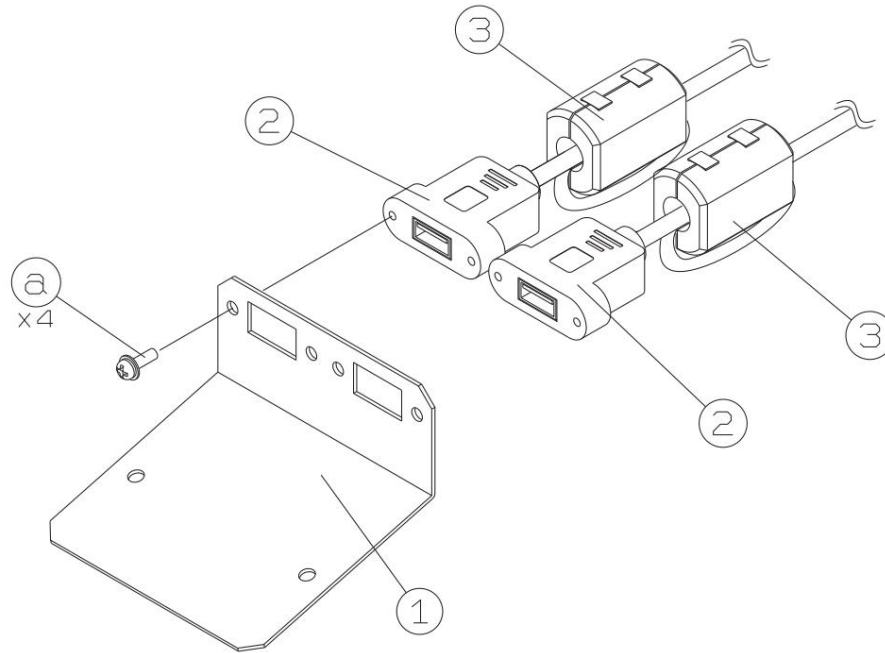

Assembly, USB slot

No.	Part Number	Product name	Model/Specification	Quantity	remarks
1	113311170000	BRACKET,USB(B)		1	
2	113348190000	CABLE, USB		2	
3	112376290000	FILTER CLAMP		2	

ASS'Y, USB SLOT screws and spare parts

No.	Product name	Model/Specifications	Quantity	remarks
a	Washer assembled cross recessed pan head screw M3x10 SW,PW (No. 2 + polished round) 4 Chromate			

The parts contents may vary depending on the shipping time.

Fig.34 UNIT, CABINET (1/6)

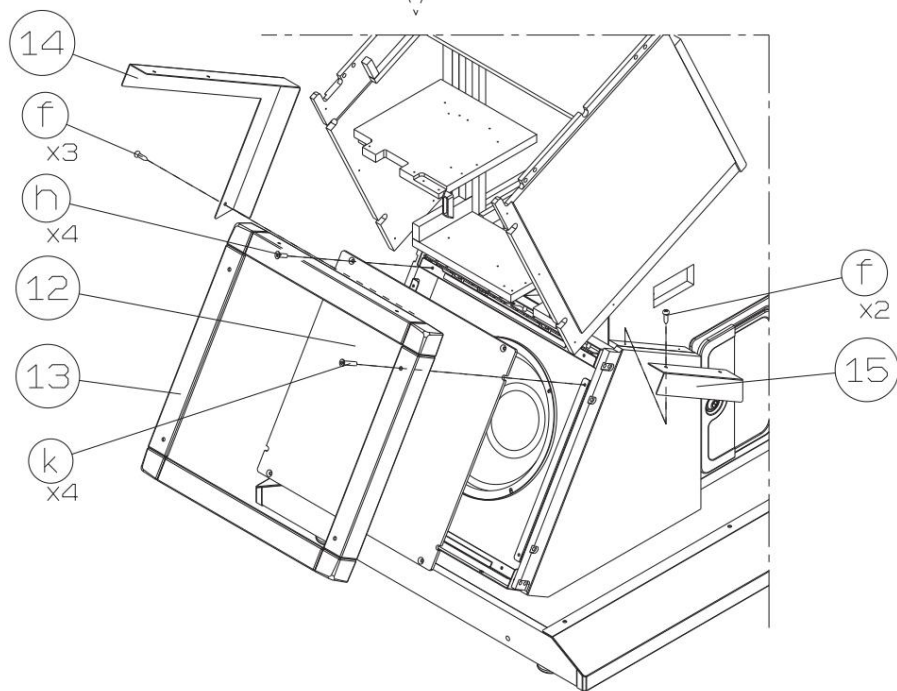
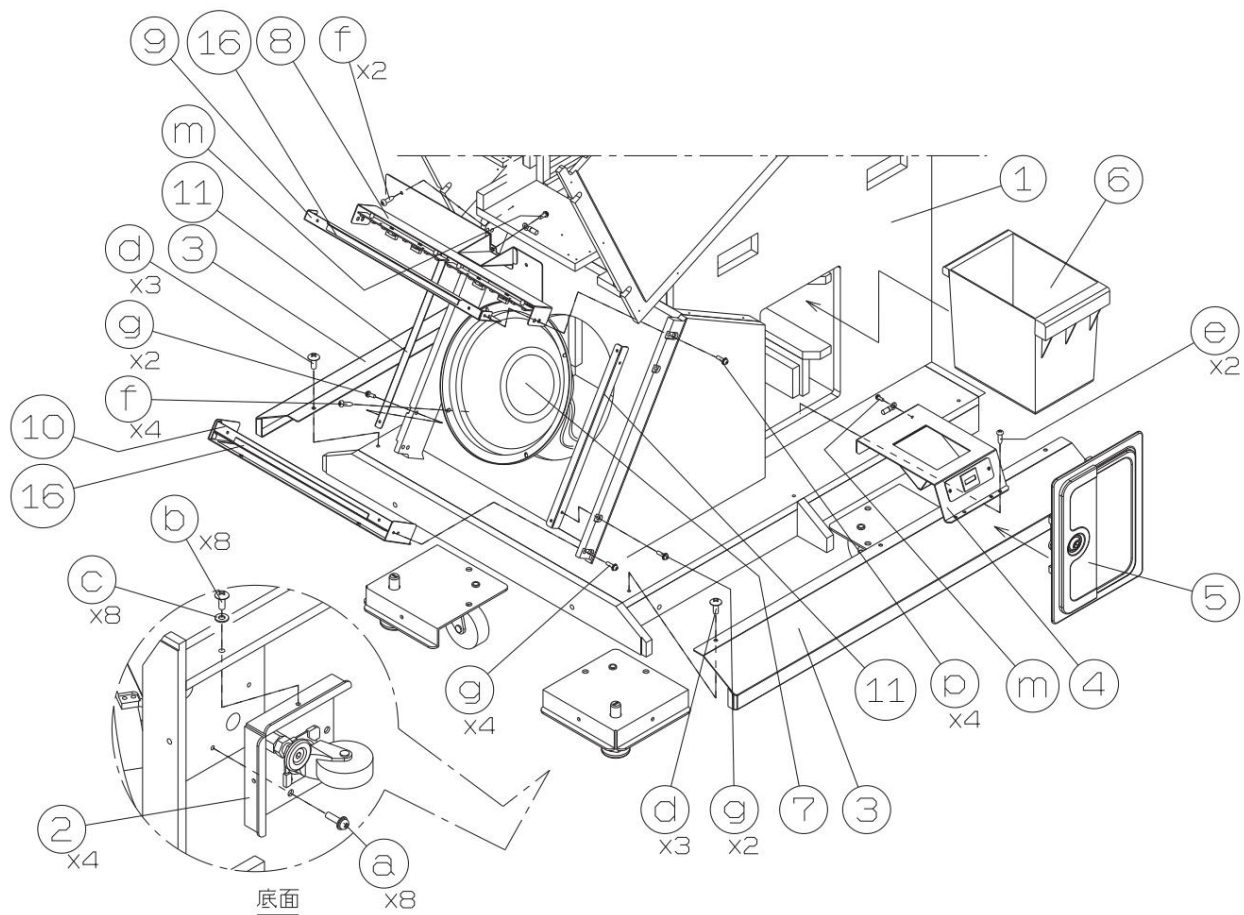

UNIT, CABINET(1/6)

No.	Part Number	Product name	Model/Specification	Quantity	Remarks
1		CABINET, MAIN		1	
2	000725910000	SET, ADJUSTER		4	
3	112373860000	COVER, FLOOR		2	
4	113535810000	ASS'Y, COIN BASE		1	See Fig.32
5	112374500000	ASS'Y, COIN DOOR		1	See Fig. 7
6	002396790000	BOX, COIN		1	
7	111994230000	SPEAKER		1	
8	114646350000	ASS'Y, WOOFER LED		1	See Fig. 9
9	112899280000	COVER, LED		1	
10	112899290000	FRAME, WOOFER (LOW)		1	
11	112899320000	BRACKET, COVER (W)		2	
12	112368500000	PANEL, WOOFER		1	
13	112483830000	ASS'Y, COVER (AT)		1	See Fig.8
14	112899300000	COVER, WOOFER (L)		1	
15	112899310000	COVER, WOOFER (R)		1	
16	112483010000	TAPE, SPONGE (G)		2	

UNIT, CABINET (1/6) Screws and spare parts

No.	Model/Specifications	Quantity	remarks
	Product name a Washer assembled cross recessed pan head screw M6x20 SW,PW (No. 2 + polished round) 8 Chromate		
b	Cross recessed truss head M6x25	8	Black chromate
screw c	Flat Call 6 (D20 T1.6)	8	Black chromate
washer d	Cross recessed truss M5x15	6	Chromium
head screw e	Cross recessed round wood screw No. 3.1x13 f	2	Chromate
	Cross recessed truss tapping screw No. 4x12 g Washer- (1 type)	11	Black chromate
	integrated cross recessed pan head screw M4x15 SW,PW (No. 2 + polished round) 8 Chromate		
h	Cross recessed flat head machine screw 4 Chromated M4x10		
k	Hexagon socket extra low head bolt 4 Black chromate M4x16		
m	Washer assembled cross recessed pan head screw M4x10 SW,PW (No. 2 + polished round) 2 Chromate		
p	Washer assembled cross recessed pan head screw M4x20 SW,PW (No. 2 + polished round) 4 Chromate		

The parts contents may vary depending on the shipping time.

Fig.35 UNIT, CABINET (2/6)

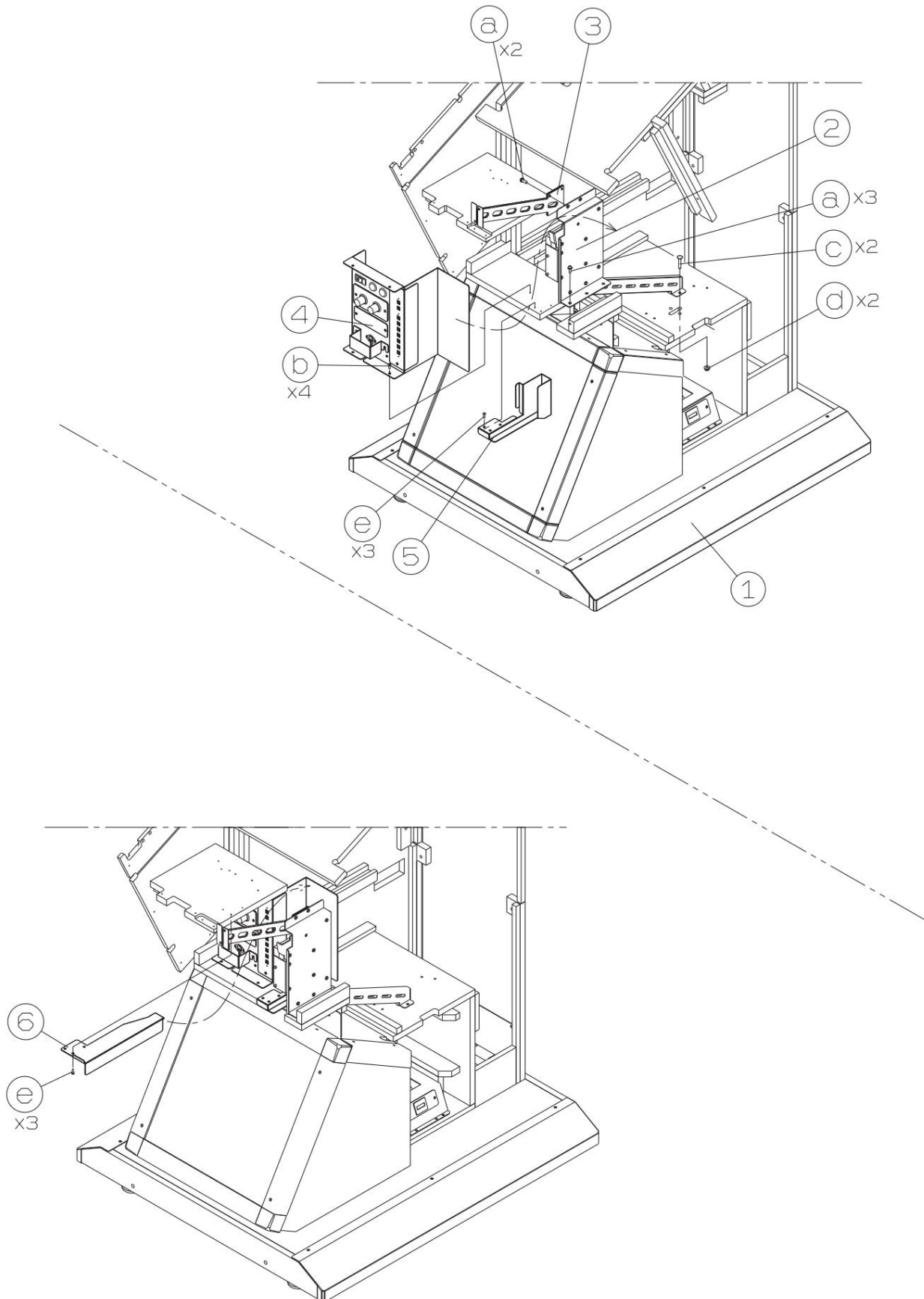

UNIT, CABINET(2/6)

No.	Part Number	Product name	Model/Specification	Quantity	remarks
1		UNIT, CABINET(1/6)		1	See Fig. 34
2	113337940000 ASS'Y,	COIN MECH		1	See Fig. 10
3	112899350000 RAIL,	COIN(A)		1	
4	114640980000 ASS'Y,	SERVICE		1	See Fig. 11
5	114644960000 COVER	BOTTOM		1	
6	114644930000 COVER	TOP		1	

UNIT, CABINET(2/6) Screws and spare parts

No.		Model/Specifications	Quantity	remarks
	Product name a Washer assembled cross recessed pan	head screw M4x15 SW,PW (No.2 + polished round)	5	Chromate
b	Cross recessed wood screw 4 chromate	Call 3.1x13		
c	Square head bolt 2 chrome	M4x20 (Type A, Type 1)		
d	Flange hexagon nut 2 Chromated with serrations	M4		
e	Cross recessed truss tapping screw 6 Black chromate	Call 3.5x12 (1 type)		

The parts contents may vary depending on the shipping time.

Fig.36 UNIT, CABINET (3/6)

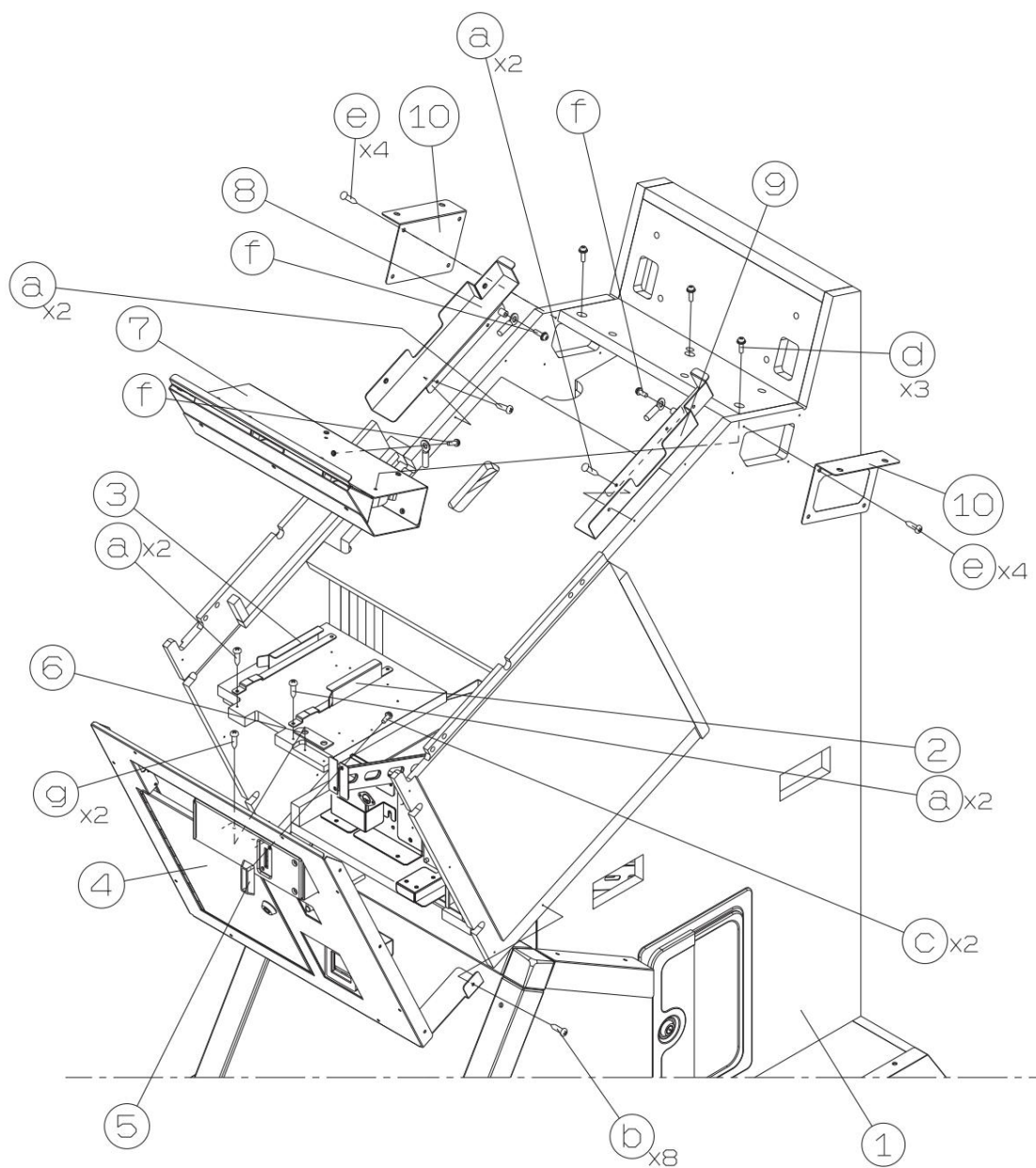

UNIT, CABINET(3/6)

No.	Part Number	Product name	Model/Specification	Quantity	remarks
1		UNIT, CABINET(2/6)		1	See Fig. 35
2	112899330000 RAIL	GUIDE(A)		1	
3	112899340000 RAIL	GUIDE(B)		1	
4	112901070000 ASS'Y	,FRONT PANEL		1	See Fig. 14
5	111764210000 ENTRY	, COIN		1	
6	112477280000 PLATE	,SPACER		1	
7	112901140000 ASS'Y	, FAN		1	See Fig.12
8	112899730000 BKT,	LCD COVER (L)		1	
9	112899740000 BKT,	LCD COVER(R)		1	
10	112899830000 BKT,	SPEAKER BOX		2	

UNIT, CABINET(3/6) Screws and spare parts

No.		Model/Specifications	Quantity	remarks
	Product name: Cross recessed round wood screw, size 3.1x13, 8, chromate			
b	Cross recessed round wood screw size 3.1x8 8 chromate			
c	Washer assembled cross recessed pan head screw M3x8 SW,PW (No. 2 + polished round) 2 Chromate			
d	Washer assembled cross recessed pan head screw M4x20 SW,PW (No. 2 + polished round) 3 Chromate			
e	Cross recessed truss tapping screw	Call 3.5x12 (1 type)	8	Black chromate
	assembled cross recessed pan head screw M4x10 SW,PW (No. 2 + polished round) 3 Chromate			
g	Cross recessed round wood screw	Call 3.1x10		

The parts contents may vary depending on the shipping time.

Fig.37 UNIT, CABINET (4/6)

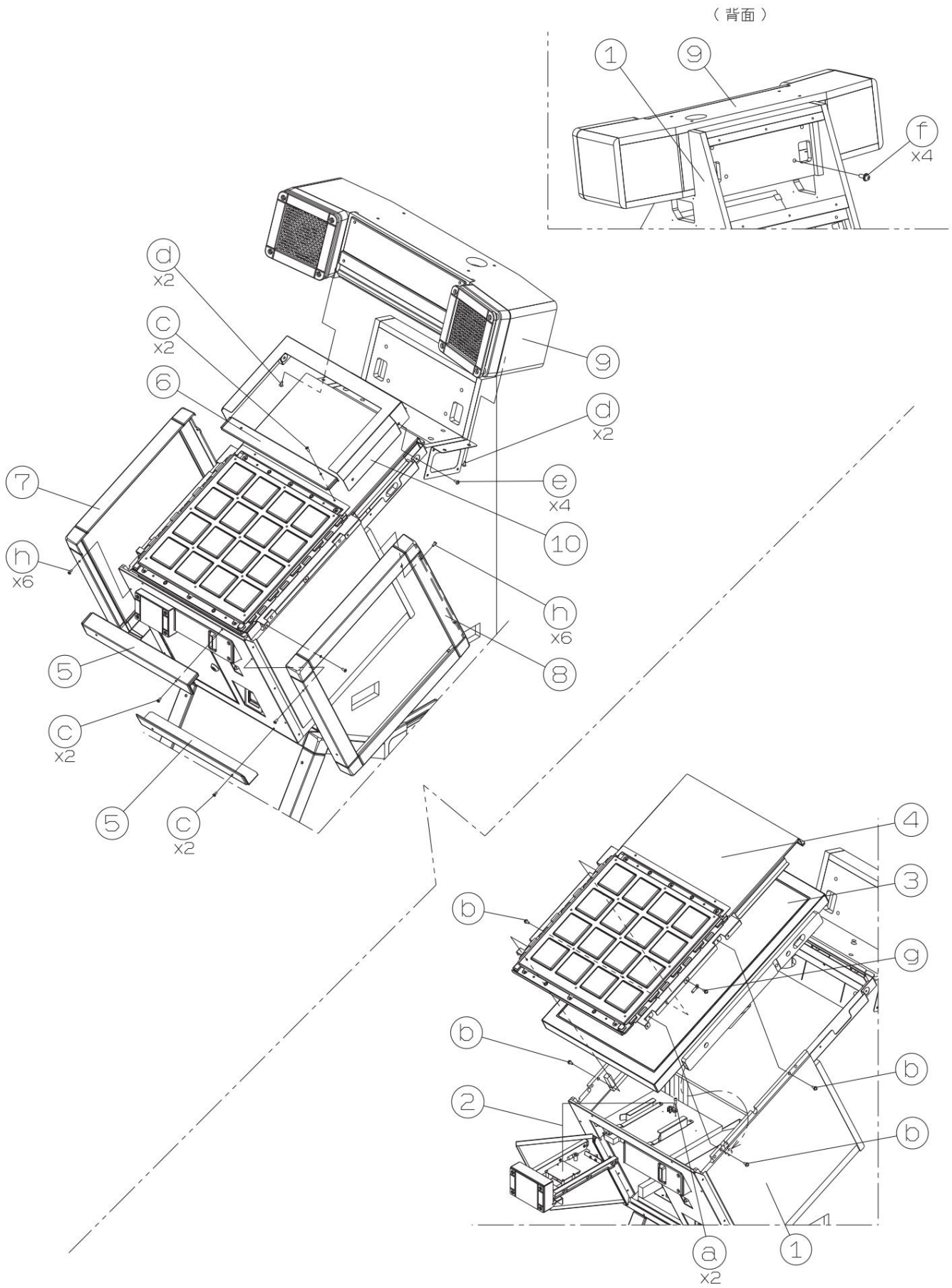

UNIT, CABINET(4/6)

No.	Part Number	Product name	Model/Specification	Quantity	Remarks
1		UNIT, CABINET(3/6)		1	See Fig. 36
2	114382070000	UNIT, IC CARD		1	See Fig. 15
3	114654240000	Assembly, LCD		1	See Fig. 16
4	112901030000	UNIT, CONTROL		1	See Fig. 4
5	112374660000	ASS'Y, COVER(B)		2	See Fig. 17
6	112317210000	COVER, CUBE(BL)		1	
7	112374670000	ASS'Y, COVER(ATL)		1	See Fig. 18
8	112374680000	ASS'Y, COVER(ATR)		1	See Fig. 19
9	113276820000	ASS'Y, SPEAKER BOX		1	See Fig.22
10	112899390000	ESCUTCHEON		1	

UNIT, CABINET(4/6) Screws and spare parts

No.	Item Name	Quantity	Model/Specifications	remarks
a	Cross recessed wood screw 2 chromate		Call 3.1x13	
b	Washer assembled cross recessed pan head screw		M4x15 SW,PW (No. 2 + polished round) 4 Chromate	
c	Hexagon socket extra low head bolt		M4x10	6 Black chromate
d	Cross recessed truss head screw		M6x20	4 Black chromate
e	Cross recessed truss head screw		M4x10	4 Black chromate
f	Washer assembled cross recessed pan head screw		M6x35 SW,PW (No.2 + polished round) 4 Chromate	
g	Washer assembled cross recessed pan head screw		M4x10 SW,PW (No. 2 + polished round) 1 Chromate	
h	Hexagon socket extra low head bolt		M4x16	12 Black chromate

The parts contents may vary depending on the shipping time.

Fig.38 UNIT, CABINET (5/6)

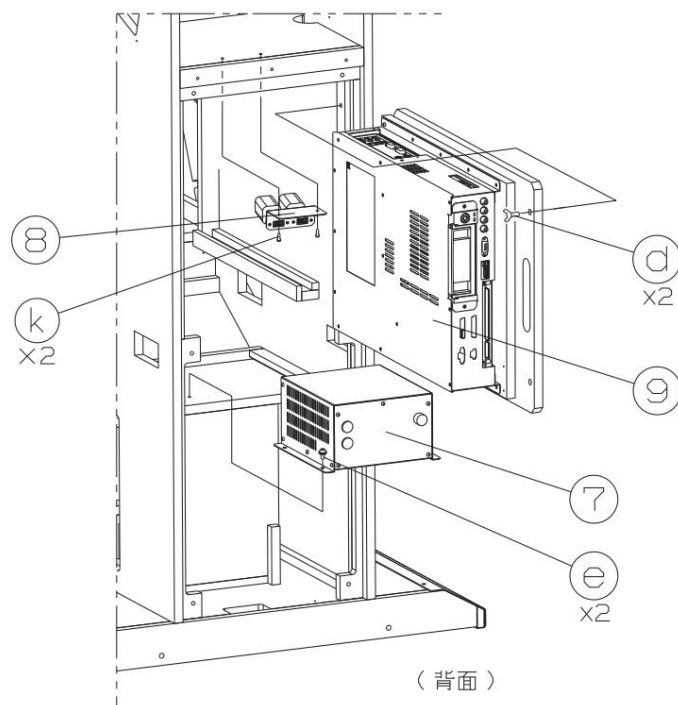
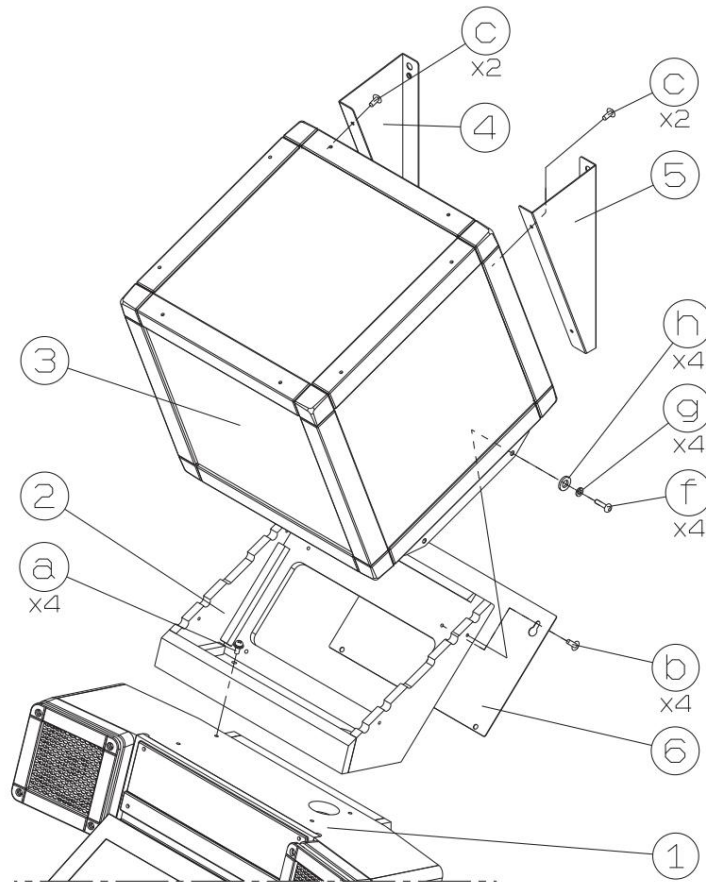

UNIT, CABINET(5/6)

No.	Part Number	Product name	Model/Specification	Quantity	Remarks
1		UNIT, CABINET(4/6)		1	See Fig. 37
2	112373640000	BASE, TITLE		1	
3	114659910000	UNIT, TITLE		1	See Fig. 31
4	112899840000	BRACKET, POP(L)		1	
5	112899850000	BRACKET, POP(R)		1	
6	112885330000	COVER, BACK		1	
7	111732770000	TRANSFORMER		1	
8	113535940000	ASS'Y, USB SLOT		1	See Fig. 33
9		Assembly, main PCB		1	See Fig. 1

UNIT, CABINET(5/6) Screws and spare parts

No.	Product name	Model/Specifications	Quantity	remarks
a	Washer assembled cross recessed pan head screw M6x35 SW,PW (No.2 + polished round)		4	Chromate
b	Cross recessed truss head screw 4 Black chromate	M6x15		
c	Cross recessed truss head screw 4 Black chromate	M4x15		
d	Wing bolt 2 Chromate	M6x25 (2 types)		
e	Washer assembled cross recessed pan head screw M4x15 SW,PW (No.2 + polished round)		2	Chromate
f	Hexagon socket button bolt g Spring	M6x25	4	Black chromate
h	washer Flat	No.6 (No.	4	Black chromate
k	washer	No.6 2) (Migakimaru)	4	Black chromate
	Cross recessed truss tapping screw	No.3.5x12 (1 type)	2	Black chromate

The parts contents may vary depending on the shipping time.

Fig.39 UNIT, CABINET (6/6)

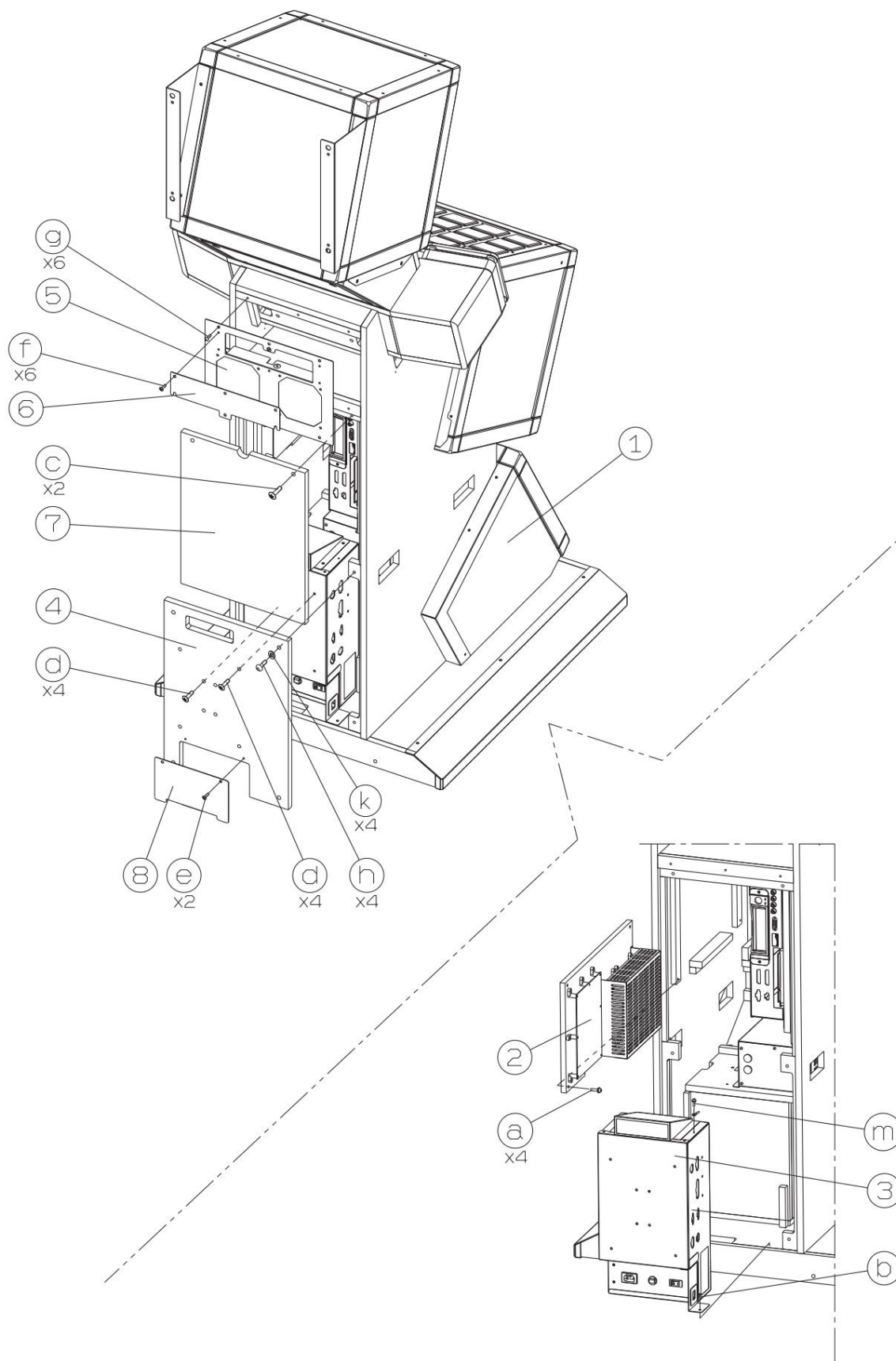

UNIT, CABINET(6/6)

No.	Part Number	Product name	Model/Specification	Quantity	Remarks
1		UNIT, CABINET(5/6)		1	See Fig. 38
2	114646370000	Assembly, board, PCB		1	See Fig.20
3	114435980000	ASS'Y POWER BOX		1	See Fig. 6
4	112373630000	COVER,BACK		1	
5	112901010000	ASS'Y FAN PANEL		1	See Fig.21 Including No.6
6	112899760000	COVER,PANEL		1	
7	112373610000	COVER,REAR		1	
8	112899860000	COVER,CABLE		1	

UNIT, CABINET(6/6) Screws and spare parts

No.	Product name	Model/Specifications	Quantity	remarks
a	Washer assembled cross recessed pan head screw M4x25 SW,PW (No.2 + polished round)		4	Chromate
b	Cross recessed wood screw 1 Chromated	Call 3.1x13		
c	Cross recessed truss head screw 2 Black chromate	M6x30		
d	Cross recessed truss head screw 8 Black chromate	M5x25		
e	Cross recessed truss head screw 2 Black chromate	M4x15		
f	Cross recessed truss head screw 6 Black chromate	M4x10		
g	Hexagon socket button bolt 6 Black chromate	M4x15		
h	Hexagon socket button bolt 4 Black chromate	M6x30		
k	Flat washer (D20 T1.6) 4 Black chromate	Call 6		
m	Washer assembled cross recessed pan head screw M4x15 SW,PW (No.2 + polished round)		1	Chromate

The parts contents may vary depending on the shipping time.

Fig.40 UNIT, ATTACHMENT

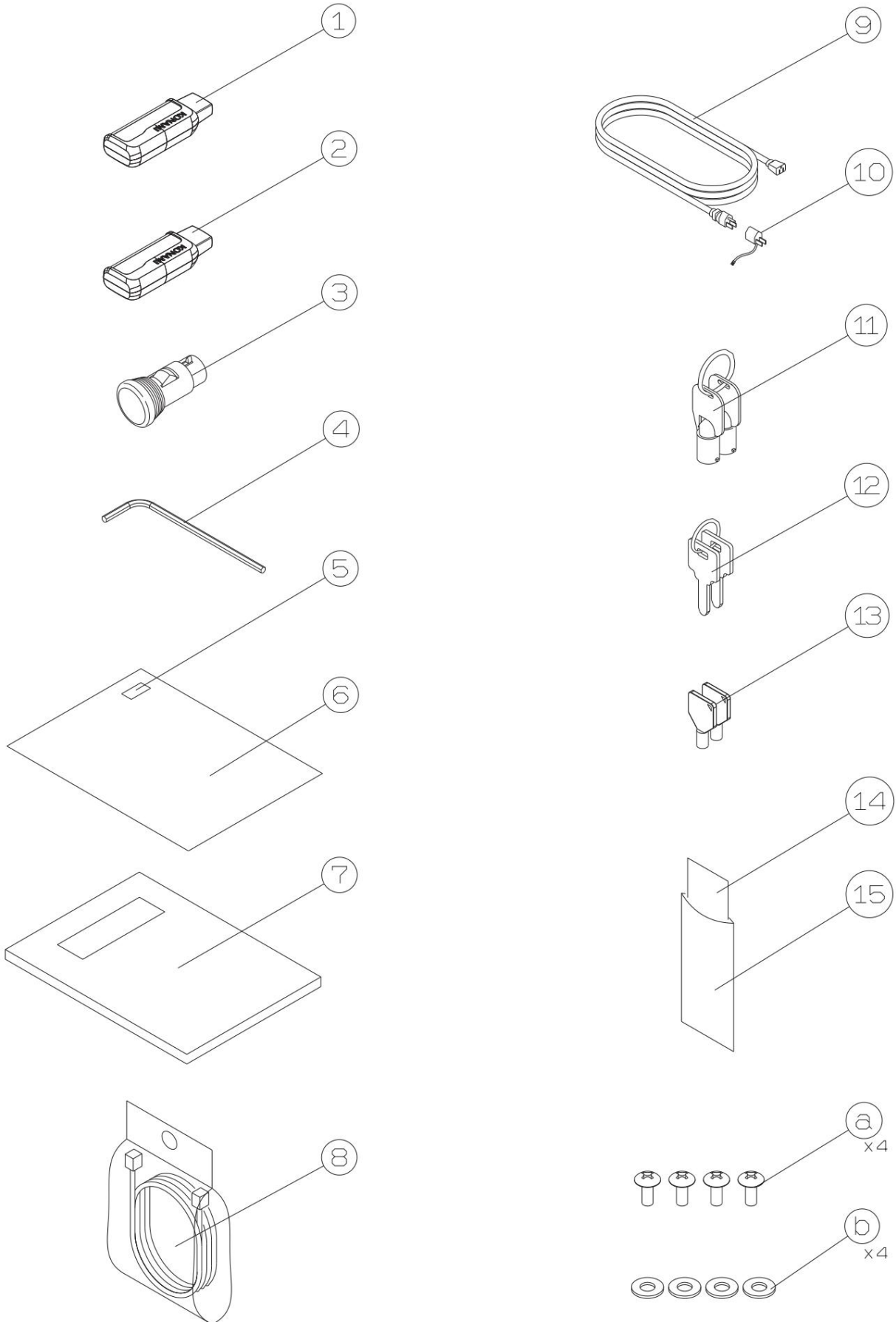

Unit, Attachment

No.	Part Number	Model/Specification	Quantity	Remarks
1		Product name: UNIT, SECU.USB (BK)		1 License Key (black)
2		UNIT, SECU.USB(WT)		1 Account key (white)
3		UNIT, SECU.PLUG(B)		1 security plug (black)
4	114323770000 WREN	CH,HEX KEY	B2.5	1
5		SEAL, LICENSE		1
6		SHEET, LICENSE		1
7	114589440000 BOOK	MANUAL		1 Instruction Manual
8	112472750000 CABLE	E,LAN	10m	1
9	001267400000 CORD	,POWER		1
10	112979150000 ADAPTER			1
11	000974240000 LOCK			1 2 keys + cylinder
12	002652030000 LOCK			1 2 keys + cylinder
13	111659720000 KEY,HD(R			1 key only (set of 2)
14		BOOK,WARRANTY		1 Warranty card
15		BAG, WARRANTY		1 Warranty bag

UNIT,ATTACHMENT Screws and auxiliary materials

No.	Model/Specifications	Quantity	remarks
Product name a Cross recessed truss	M6x15	4	Black chromate
head screw b Flat washer	Call 6 (D20,T1.6)	4	Black chromate

The parts contents may vary depending on the shipping time.

Wiring diagram

Wiring diagram 1/4

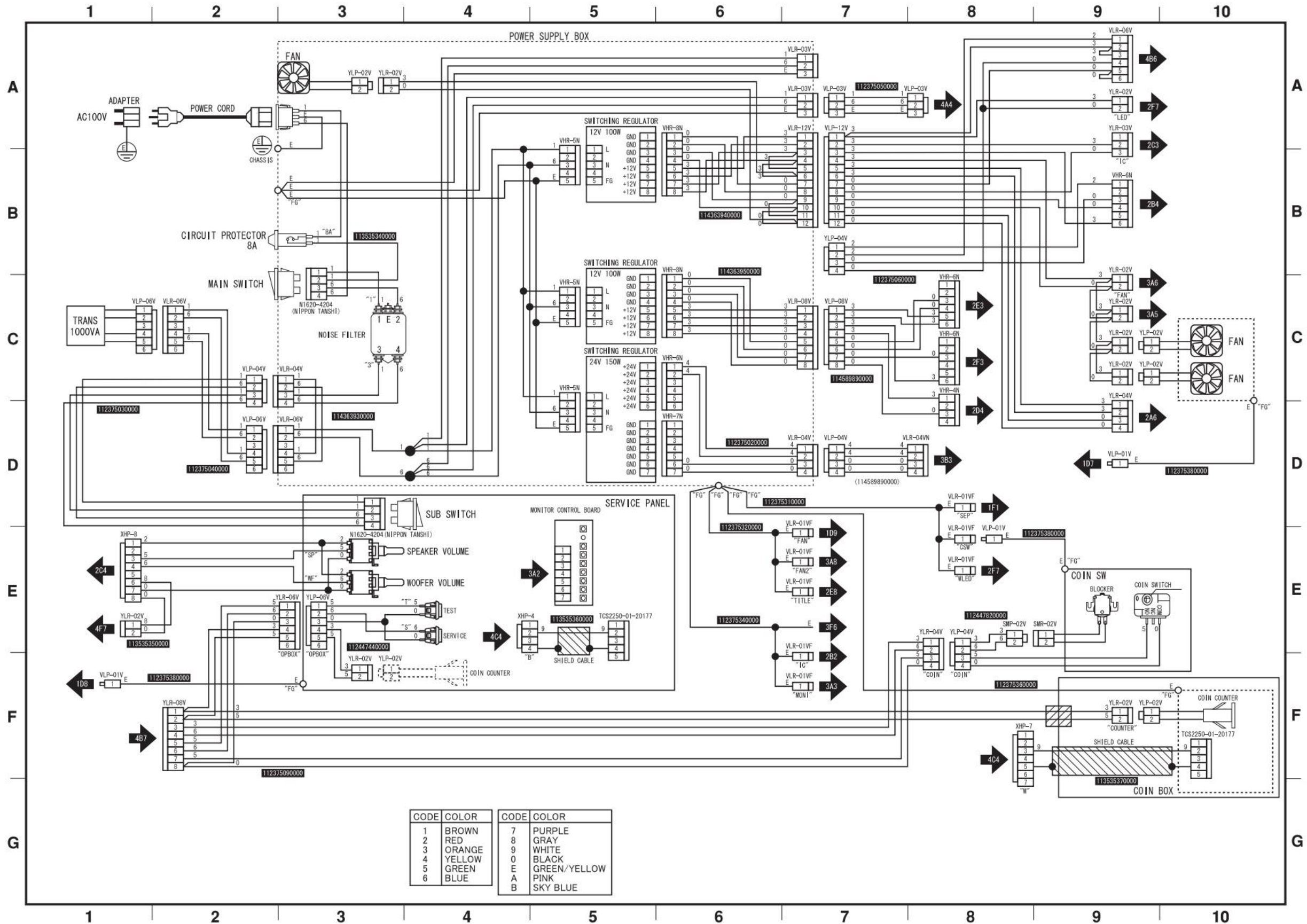

The parts contents may vary depending on the shipping time.

Wiring diagram 2/4

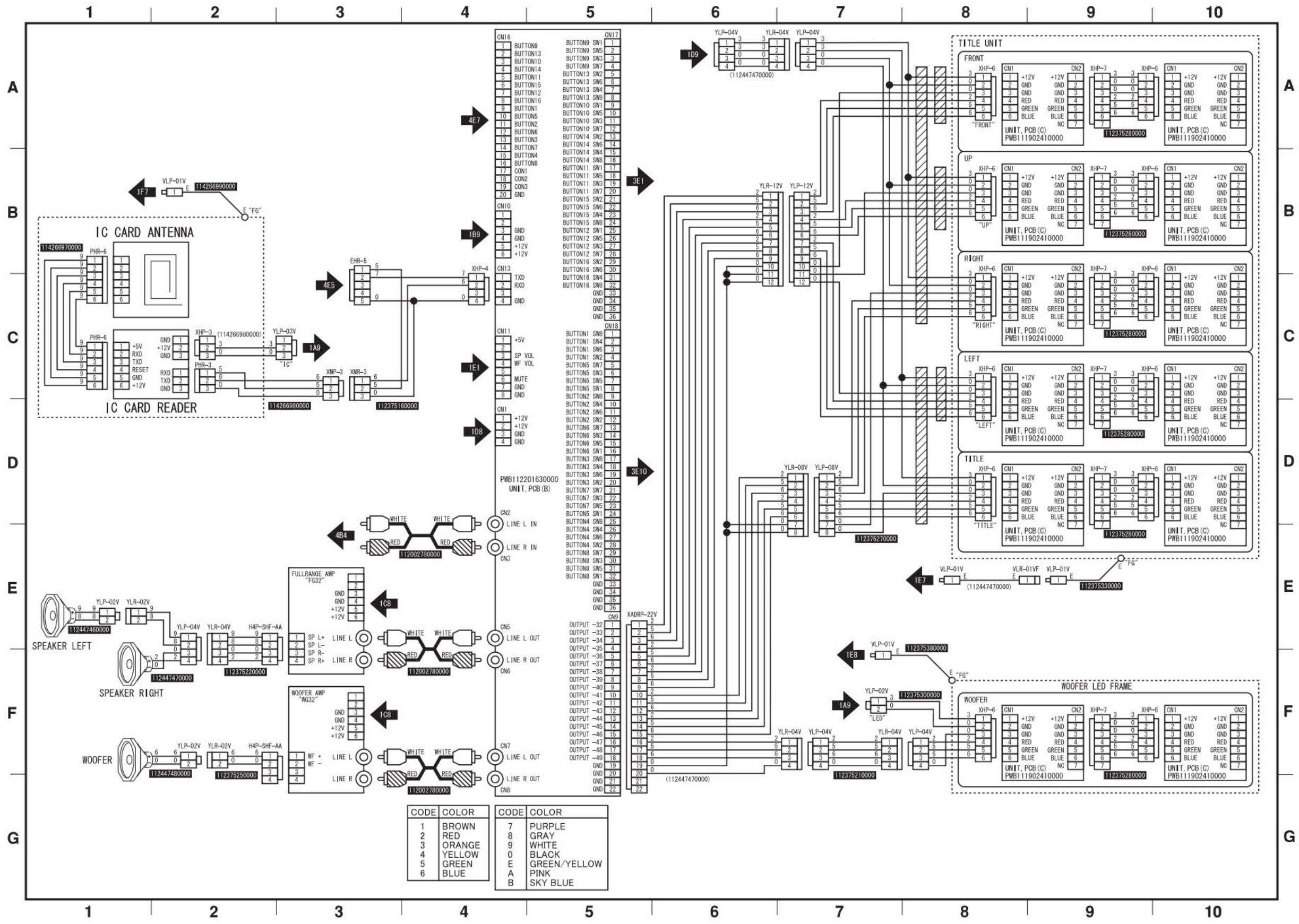

The parts contents may vary depending on the shipping time.

Wiring diagram 3/4

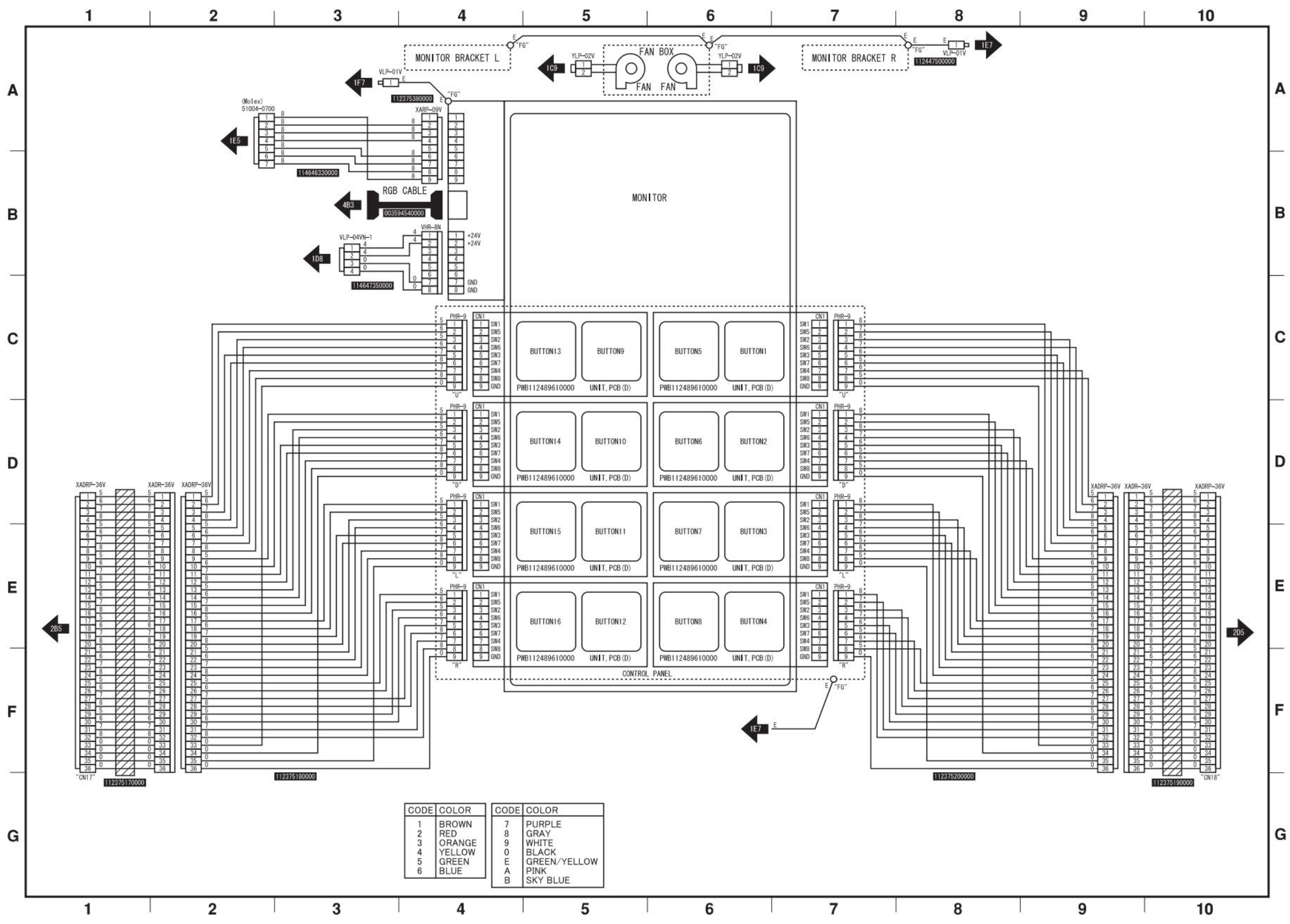

The parts contents may vary depending on the shipping time.

Wiring diagram 4/4

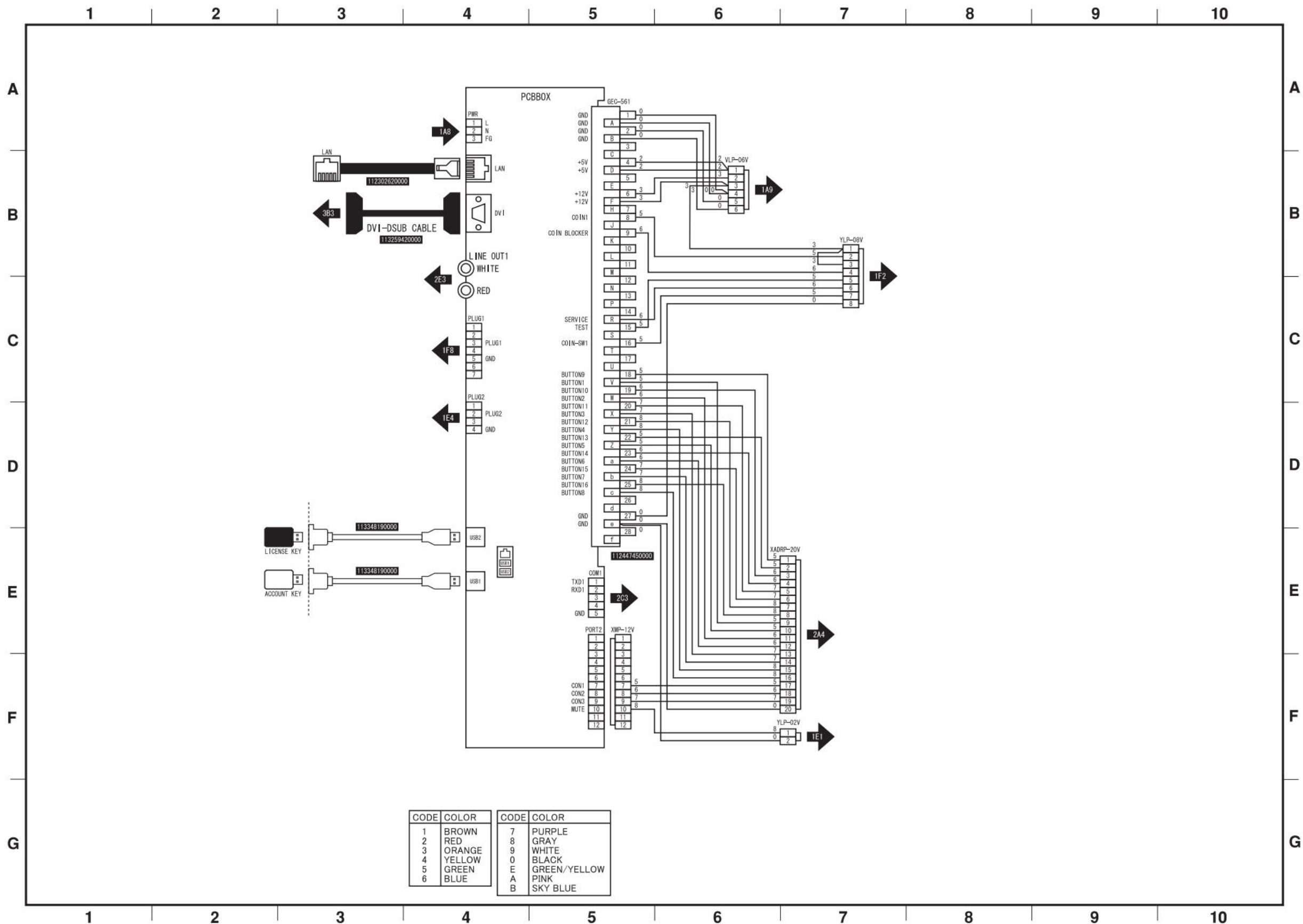

The parts contents may vary depending on the shipping time.

About after-sales service

About the warranty

Please check the warranty card (the warranty card is attached to the protective bag of the main unit) After checking that all the required information has been filled in on the warranty card, read the warranty regulations carefully

and keep it in a safe place. The warranty period is

the period specified on the warranty

card. When requesting repairs Please contact the

after-sales service center. Also, before deciding that the product is broken, please read the instruction manual and check that it is

being used correctly. Regarding

repairs during the warranty period Please contact the after-sales service center. Repairs will be carried out in accordance

with the information written on the warranty

card. Regarding repairs after the warranty period Please

contact the after-sales service center. If performance can be maintained through repairs, repairs will

be carried out at your request for a fee. In the event that repairs are carried out during or after the warranty period, replacement parts may be used

Please note that there may be cases where this is not possible.

If the product is damaged or broken due to improper use, or if consumable parts and accessories other than the main unit are damaged or broken, the warranty period will be extended.

Please note that even if the damage is within the scope of the warranty, it is not covered by the warranty.

About after-sales service desk We have set up an after-

sales service desk to assist customers in the unlikely event that a product you purchased breaks down. If the product continues to be in an abnormal state or does not

function properly, immediately turn off the main power switch, unplug the power cord from the outlet, and contact the after-sales service desk. The after-sales service desk is open 365 days a year and can handle

purchasing parts, repairs, e-AMUSEMENT, and other inquiries.

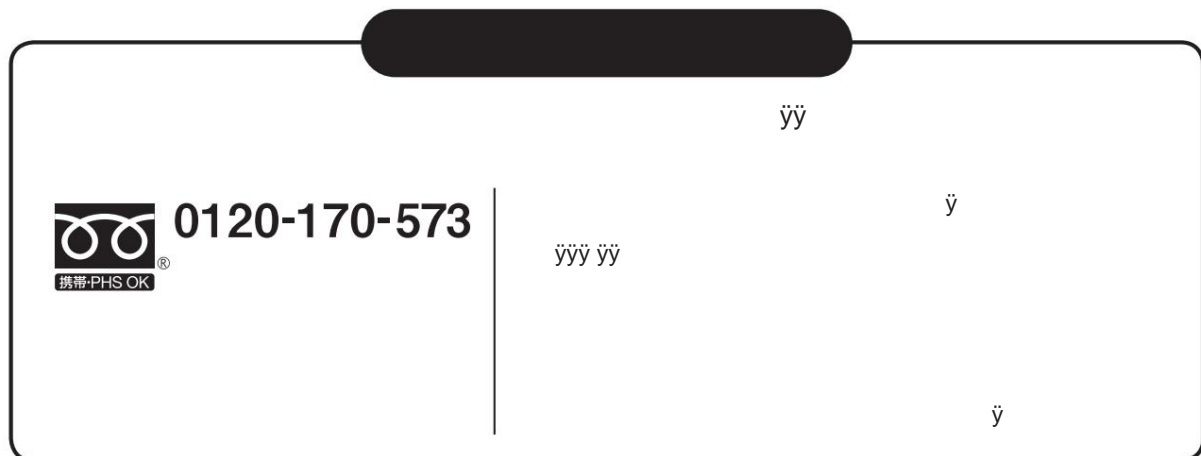

Retention period for repair parts

ÿ Replacement performance parts

Replacement performance parts are parts necessary to maintain the functionality of the product and are stocked as shown below.

Five years after discontinuation

ÿ Repair period

The above retention period is the period during which repairs are possible.

Even after the warranty period has expired, repairs may be possible depending on the defective part.
Please contact our service department.

List of consumable parts

Part Name	Part Number
Coin selector microswitch Rubber switch	111718820000
(1 pc.) Rubber switch	112317280000
(set of 64 pcs.) Please contact	113271470000

our after-sales service department to purchase consumable parts.

