



ORIGINAL VIDEO GAME  
**OPERATOR'S MANUAL**

■ **Dance Dance Revolution** ■



© 1998 KONAMI  
ALL RIGHTS RESERVED.



- Failure to operate the machine correctly could result in malfunction or accidents, so please read this manual carefully before commencing operation. Be sure to operate the machine as described in this manual.
- Keep this manual carefully so as to be ready for use when necessary.

# About this product

---

Thank you for purchasing this KONAMI product. This manual explains how to operate your game machine correctly and safely.



- **Failure to operate the machine correctly could result in malfunction or accidents, so please read this manual carefully before commencing operation. Be sure to operate the machine as described in this manual.**
- **Keep this manual carefully so as to be ready for use when necessary.**
- **If the machine still fails to display or to get started, immediately turn OFF the main power switch and contact your nearest dealer.**

• **This manual covers the following models:** \_\_\_\_\_

• **GN845-UC**

---

- The specifications of this product are subject to change without notice for reasons such as improving the performance.
- The contents of this game, its main devices and design are protected under each law concerning patent, copyright and other intellectual properties.
- Unauthorized reproduction of this document or any of its contents is strictly forbidden.

© 1998 KONAMI ALL RIGHTS RESERVED.

# Contents

---

■	Precautions for use .....	2
■	Locations of warning and other safety labels .....	7
1	Specifications .....	8
2	Names of parts .....	10
3	How to play .....	11
4	<b>Opening and closing the doors</b>	
4-1	Opening and closing the maintenance door .....	12
4-2	Opening and closing the coin door .....	13
5	<b>Game settings</b>	
5-1	Checking the game performance .....	14
5-2	Setting and adjustment of game mode .....	15
5-3	Mode descriptions .....	16
6	<b>Installation and assembling</b>	
6-1	Connection of units .....	23
6-2	Fastening the adjusters .....	26
6-3	Power unit .....	27
6-4	Service panel .....	27
6-5	External output terminals .....	28
6-6	Mounting billboards .....	29
6-7	Splitting into and moving of units .....	30
6-8	Moving the coin counter .....	31
7	<b>Maintenance</b>	
7-1	Replacing the coin selector .....	32
7-2	Replacing the fluorescent light .....	33
7-3	Replacing the spotlight lamp .....	34
7-4	Replacing the button .....	35
7-5	Maintenance of foot switch .....	37
7-6	Resetting the circuit protector .....	39
7-7	Adjusting the monitor .....	40
8	<b>Annex</b>	
8-1	Label locations and exploded view .....	41
8-2	Wiring diagram .....	63

# ■ Precautions for use

---

The following safety precautions are given throughout this manual. They must be strictly followed to protect those who install, use or maintain this product as well as to prevent other people's injuries and property damages.

## Be sure to read the following

- The following suggestions show the degree of danger and damage caused when the product is used improperly with the suggestions disregarded.



Indicates a situation where disregarding the suggestions could result in death or serious injury.



Indicates a situation where disregarding the suggestions could result in injury or product damage.

- The following graphic suggestions describe the types of precautions to be followed.



Indicates a matter of which care should be taken.



Indicates a matter which is forbidden.



Indicates a matter which should be performed without fail.

- Definitions of qualified in-shop maintenance persons and industry specialist who handle this product.

•In this instruction manual, some procedures require a qualified in-shop maintenance person or industry specialist. For such instructions, a qualified person must take care of the jobs.

·Otherwise an electric shock, machine trouble, or a serious accident may result.

·Replacing the machine parts, inspecting and maintaining the machines, and troubleshooting must be assigned only to a qualified in-shop maintenance person or industry specialist. This booklet gives instructions that hazardous jobs in particular must be handled by an industry specialist. Qualified in-shop maintenance persons and industry specialist are defined as follows.

### Qualified in-shop maintenance persons

·A qualified in-shop maintenance person must have experiences in maintaining amusement machines, money changers and the like. Under the supervision of an amusement machines shop owner or manager, he or she routinely assembles, installs, inspects and maintains the amusement machines, or replaces their component units and consumable parts, in the amusement machines workshop and/or shop.

### Jobs handled by qualified in-shop maintenance persons

·Assembling, installing, inspecting and maintaining amusement machines and money changers, and replacing their component units and consumable parts.

### Industry specialist

·An industry specialist must be engaged in designing, manufacturing, inspecting and servicing amusement machines. Or he or she must have an education in electrical, electronic and mechanical engineering, and routinely maintain and repair amusement machines.









### Jobs handled by industry specialist

·Assembling and installing amusement machines and money changers, and repairing and adjusting their electrical, electronic and mechanical component parts.

## Setting Up







### WARNING

- **Be sure to consult your nearest dealer when setting up, moving or transporting this product.**  
 · This product should not be set up, moved or transported by anyone other than industry specialist. Doing so could result in injury or product damage.  
 · When installing this product, set the 12 adjusters stable on the floor and make sure that the product is installed stably in a horizontal position. Unstable installation may result in injury or accident.  
 · When installing this product, use care not to apply undue force to opening and closing parts and other movable parts. Otherwise, injury or accident may result, or the product may be damaged.
- **This product is an indoor game machine. Never set up the game machine outside.**   
 · Setting up this product outside could result in accidents or equipment failure.
- **Do not set up the game machine near emergency exits.**   
 · Doing so could block exits in time of emergency and could result in death or serious injury.
- **Do not set up the game machine.**   
 · Otherwise an accident or malfunction may result.  
 · In a place exposed to rain or moisture.  
 · In a place exposed to direct sunlight.  
 · In a place exposed to direct heat from air-conditioning and heating equipment, etc..  
 · Near hazardous flammable substance such as thinner and kerosene.  
 · On an inclined or uneven floor.  
 · Near fire extinguishing equipment.  
 · In a place exposed to strong vibration.  
 · In a place exposed to excessive dust.  
 · Near equipment generating strong magnetism or electric waves.
- **Do not place containers holding chemicals or water on or near the game machine.**   
 · Electrical shock or damage could be caused by water or foreign matter entering the inside of the machine.
- **Do not place objects near the ventilating holes.**   
 · Doing so could cause the internal temperature to rise excessively, resulting in fire or equipment failure.
- **Do not bend the power cord by force or place heavy objects on it.**   
 · Doing so could result in electric leakage or fire.
- **Never plug or unplug the power cord with wet hands.**   
 · Doing so could result in electrical shock.
- **Never unplug by pulling the power cord.**   
 · Doing so could damage the cord, resulting in electric leakage or fire.

## Setting Up



### CAUTION

- **Be sure to use indoor wiring for within the specified voltage range. For extension cord, use indoor wiring of the specified rating or more.**  
· Failure to do so could result in fire or equipment failure.
- **Be sure to use the attached power cord.**  
· Otherwise a fire or machine trouble may result.
- **Never plug more than one cord at a time in the electrical receptacle.**  
· Doing so could result in fire or electrical shock. 
- **Do not lay the power cord where people walk through. You may tread on or stumble over them.**  
· You may stumble down and get injured, or damage the power cord. 
- **Be sure to ground this product.**  
· Otherwise an electric shock or machine trouble may be caused. 
- **Clearance of 100 mm (3.94in) or more should be created between the game machine and walls.**  
· Otherwise the machine (s) cannot be ventilated well, resulting in malfunction.
- **Do not hold the unit connection pipe when moving this product.**  
· Otherwise, it may result in an injury or accident. 
- **After the units are connected, never move the product across a step.**  
· Otherwise, it may result in an injury or accident, or damage to the units.
- **Provide a clearance of more than 200 mm (8 in) and less than 400 mm (16 in) between the stage units and the cabinet unit.**  
· If a player sticks his foot between the units, he may be injured. If a too large clearance is provided, a player who is on way of stepping down from the stage units may step on the unit connection pipe and tumbling down, resulting in a serious injury.
- **Do not change the DIP switch setting of this product to other than factory setting.**  
· Otherwise, the game can not be played properly. 

## Operation



### WARNING

- **If there is any abnormality such as smoke, bad smell or abnormal noise being emitted from the machine, immediately turn OFF the main power switch and unplug the power cord from the receptacle to stop operating it.**  
· Using the machine in abnormal conditions could result in fire or accidents. 

#### In case of abnormality

- 1 Turn OFF the main power switch.
- 2 Unplug the power cord from the receptacle.
- 3 Contact your nearest dealer.

- **Do not leave the power cord plugged improperly or covered with dust.**  
· Doing so could result in electrical shock or fire, so inspect the power cord periodically. 

## Operation



### CAUTION

- **Do not use this product anywhere other than industrial areas.**  
 ·Using in a residential area or an area next to a residential area could affect signal reception of radios, television sets, telephones, etc..



- **The following users should not play the game.**  
 ·Doing so could cause accidents or illness.

·Those under the influence of alcohol. ·Those in bad shape. ·When a player holds food in his hand.  
 ·Those suffering from or being treated for arm, wrist, leg or foot ailments.  
 ·Those suffering high blood pressure or heart ailments. ·Those pregnant or probably pregnant.  
 ·When a player wears unstable shoes like high-heeled shoes or slippery shoes, pa a player is barefoot.

- **Players should be advised of the following precautions during a play.**

·Inobservance of the precaution may cause an accident.

·Do not hang on to or lean against the safety bar.

- **Do not give impact to the glass cover.**

·Otherwise, it may result in an unexpected accident or injury.

- **If the surface of the stage units is wet, wipe it dry before playing.**

·Otherwise, a player may tumble down by slipping while playing, resulting in injury.

- **Do not give impact to the foot panel with a force more than necessary.**

·Otherwise, an unexpected accident or injury may be caused.

- **Do not plug or unplug the power cord with wet hands.**

·Doing so could result in electrical shock.

- **In handling the power cord, follow the instructions below.**

·Otherwise an electric leak, fire or electric shock may result. Normal communication play may also be impossible.

·Do not damage the power cord.

·Do not modify the power cord.

·Do not bend the power cord excessively.

·Do not twist the power cord.

·Do not heat the power cord.

·Do not pull the power cord.

·Do not bind the power cord.

·Do not tread on the power cord.

·Do not sandwich the power cord.

·Do not drive a nail into the power cord.

- **If the power cord or power plug becomes damaged, stop using the machine immediately and ask your nearest dealer to replace the parts.**

·Using a damaged power cord or power plug could result in fire or electrical shock.



## Inspection and cleaning



### WARNING

- **Be sure to turn OFF the main power switch and unplug the power cord from the receptacle before inspecting or cleaning the machine.**

·Failure to do so could result in electrical shock.

- **When replacing parts, be sure to use parts of the correct specifications. Never use parts other than the specified ones.**

·Using improper parts could result in fire or equipment failure.

- **There are high-voltaged parts inside the product. Other persons than qualified industry specialist should not open the back door. When the back door is opened, pay due attention not to touch the inside unnecessarily.**

·Otherwise an accident or electric shock may result.

- **If the sub power switch of the service panel is turned OFF without turning OFF the main power switch of the power supply unit, some parts in the units remain live. When opening the back door, be sure to turn OFF the main power switch and unplug the power cord from the receptacle.**

·Otherwise, there may arise a danger of accident or electric shock.

- **Strictly refrain from disassembly and repair of parts which are not indicated in this manual, as well as settings and remodelling.**

·Otherwise, a fire, malfunction or trouble may result.

In case of any trouble, ask your nearest dealer for repairs and other services.

Konami will not resume any responsibility for the damage to the product attributable to disassembly and repair of parts which are not indicated in this manual, as well as settings and remodelling.

- **Open and close the fluorescent light cover gently.**

·Failure to do so could result in breakage of the fluorescent lamp etc.

- **To clean the game machine, wipe it with a soft cloth dampened in a neutral detergent and wrung out.**

·Using thinner or other organic solvent or alcohol may decompose the material.

Particularly, the foot panel (acrylic resin plate) may be deformed or broken.

·Electrical shock or equipment failure could be caused by water entering the inside of the machine.



## Inspection and cleaning



### CAUTION

- **The spotlight halogen lamp is still very hot immediately after the power switch is turned OFF. Replace the lamp after confirming that it is sufficiently cooled.**  
·Otherwise, a burn or unexpected injury may result.
- **The stage units is so constructed that foreign matters such as sand etc. easily enter the clearance between the foot panel and the corner metals or the inside of the foot panel. Therefore, check it once a day, and if any foreign matter exists, detach the foot panel and remove it by brush or vacuum cleaner. (See page 45.)**  
·If foreign matter enters the clearance between the foot panel and the corner metal or the inside of the foot panel, the foot switch is kept turned ON, thus unabling the normal play or resulting in trouble.  
·If sand or foreign matter is accumulated in the recess of screw head, the screw can not be turned by screwdriver, thus making it impossible to attach or detach the foot panel or replace the foot switch.
- **Do not apply fats such as wax etc. to the top surface of the stage units including the foot panel.**  
·Player may slip to be injured.



## Moving and transportation



### CAUTION

- **The game machine contains parts such as the monitor, electronic components and precision components which are sensitive to vibrations and impacts. Great care therefore should be taken when moving and transporting the game machine. Be sure not to let the machine tip over.**
- **Before moving the machine, be sure to turn OFF the main power switch, unplug the power cord from the receptacle and remove the power cord from the machine.**  
·Stepping on or tripping over the power cord may result in an accident or damage the machine.
- **Be sure to split this product into the cabinet units from the stage units, fully lift the 12 adjusters and then move them on casters.**  
·Otherwise, an accident, breakage or trouble may result.
- **Do not hold the unit connection pipe when moving this product.**  
·Otherwise, it may result in an injury or accident.
- **Do not apply a strong force for moving the units.**  
·Otherwise, it may result in an accident or breakage of the units.
- **Do not apply a strong force to opening and closing parts or movable parts when moving this product.**  
·Otherwise, it may result in an accident or breakage of the units.



### PRECAUTION IN HANDLING

- When setting up, inspecting, maintaining, moving or transporting this product, follow the procedures and instructions set forth in this manual and perform such work safely.
- Do not remove labels of "WARNING", "CAUTION", etc. attached to the product.
- Do not set up, handle, inspect, maintain, move or transport this product under conditions equivalent to the condition of "WARNING" or "CAUTION" specified in this manual.
- If a new owner is to have this product as a result of transfer, etc., be sure to give this manual to the new owner.



# Locations of warning and other safety labels

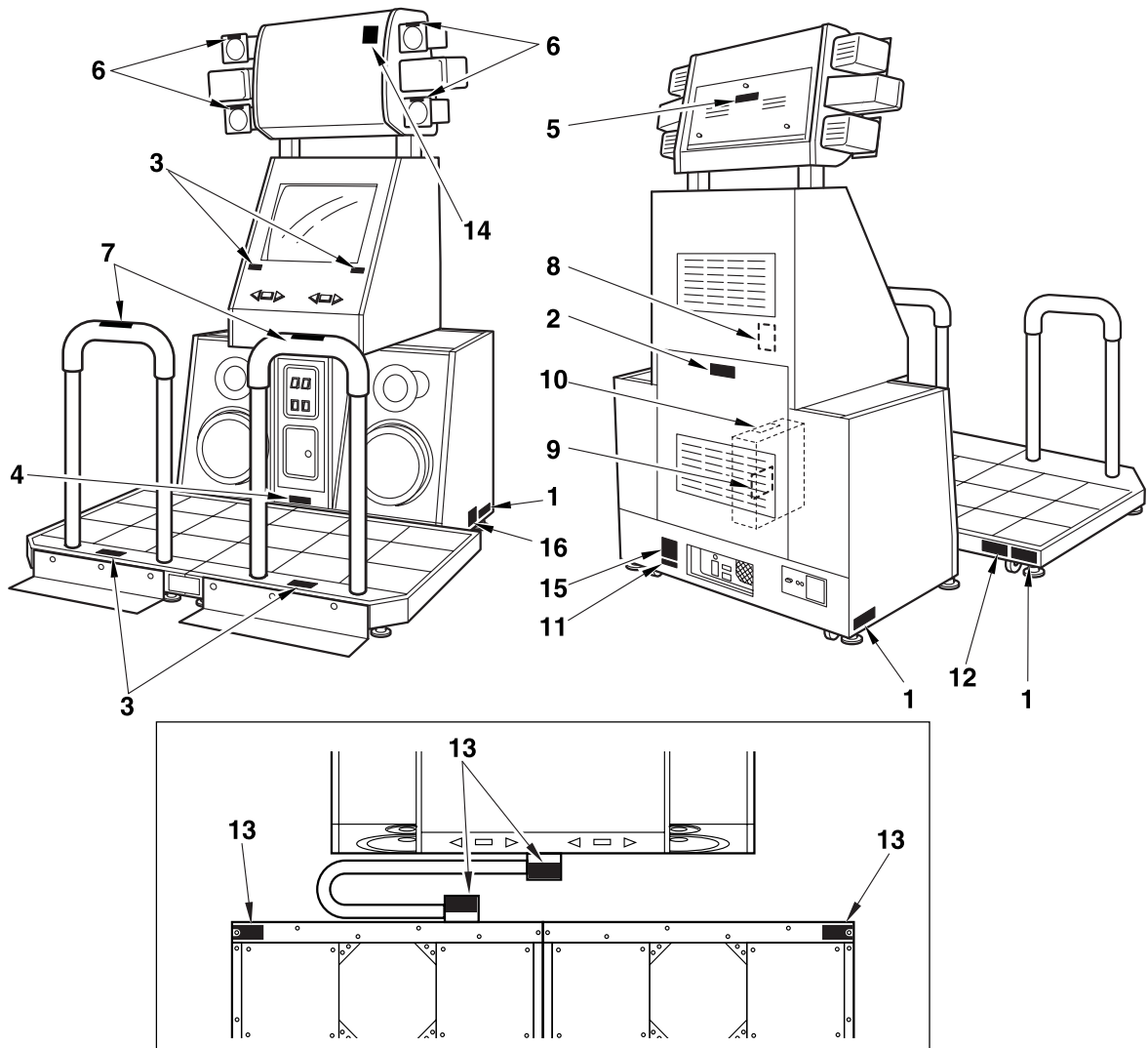

## Types of warning and other safety labels

**1** **⚠ WARNING**  
Ensure all leg levellers are securely set and game cabinet is level.

**2** **⚠ WARNING**  
ELECTRICAL SHOCK HAZARD. DO NOT OPEN EXCEPT FOR SERVICE.

**3** **⚠ CAUTION**  
Please do not play in bare feet or while wearing slippers or shoes with raised heels. The stage is elevated - please watch your step to avoid injury.

**4** **⚠ CAUTION**  
Please keep at least between 8 and 16 inches of space between cabinet unit and stage unit when game is installed.

**5** **⚠ CAUTION**  
Do not open this door roughly. The fluorescent lamps are fragile.

**6** **⚠ 高温注意 / HIGH TEMPERATURE**

**7** **⚠ Please do not lean or hang on the handrail.**

**8** **⚠ HAZARDOUS VOLTAGE**

**9** **⚠ 注意 (ちゅうい) CAUTION**

技術者以外は絶対に分解しないでください。けがや故障の原因になります。  
This product should be disassembled by qualified industry specialists only. Failure to obey this warning could result in product damage, accident and injury.

⚠ 分解禁止

⚠ 故障を修理/取り替える前に、必ず電源を切り、接地に接続されているコネクタを抜いてください。故障の原因となります。  
Turn the power OFF and disconnect the power supply from the PCB before removing the PCB cage. Failure to do so could result in product damage, accident and injury.

⚠ 取扱いには注意してください。

⚠ 使用直前に、投電カバーを開ける際は、筐体上の部品が熱くなっていることがあります。Pay careful attention when opening the PCB cage soon after play, because the contents will be hot.

⚠ ケースの上や床には、水や飲み物を入った容器や物を置かないでください。水分や異物が内部に入ると、感電や故障の原因になります。  
Do not place containers holding chemicals or water on or near the game machine. Electrical shock or damage could be caused by water or foreign matter entering the inside of the machine.

⚠ 濡れた手で触らないでください。感電することがあります。  
Do not touch this with wet hands. Doing so could cause injury and electrical shock.

⚠ 部品交換は、必ず当社指定のものを使用してください。それ以外のものを使用したり、誤装することは絶対にしないでください。故障の原因となります。  
When replacing parts, be sure to use parts of the correct specifications. Never use parts other than the specified ones. Using improper parts could result in malfunction or equipment failure.

**10** **GN845 GN845 UA** **⚠ CAUTION**  
To avoid damaging the software, please ensure that the security cable matches the game software (GD-R06).

**11** **Weight 207kg(456lb)**

**12** **Weight 100kg(221lb)**

**13** **⚠**

**14** **SUITABLE FOR ALL AGES**  
PN.000005797

**15** **THIS EQUIPMENT COMPLIES WITH THE REQUIREMENTS IN PART 15 OF FCC RULES FOR A CLASS A COMPUTING DEVICE. OPERATION OF THIS EQUIPMENT IN A RESIDENTIAL AREA MAY CAUSE UNACCEPTABLE INTERFERENCE TO RADIO AND TV RECEPTION REQUIRING THE OPERATOR TO TAKE WHAT-EVER STEPS ARE NECESSARY TO CORRECT THE INTERFERENCE. THIS DEVICE MUST ACCEPT ANY INTERFERENCE RECEIVED, INCLUDING INTERFERENCE THAT MAY CAUSE UNDESIRABLE OPERATION.**  
**KONAMI**  
PN.000000007

**16**

MODEL	GN845-UC
POWER	120 v / 60 Hz
	350 w / 450 VA
MANUFACTURER	KONAMI CO., LTD.
DATE OF MANUFACTURE	September, 1999
WEIGHT	437 Kg (963.6 lb.)
SERIAL NUMBER	
<b>KONAMI</b> MADE IN JAPAN <b>INDOOR USE</b>	

# 1 Specifications

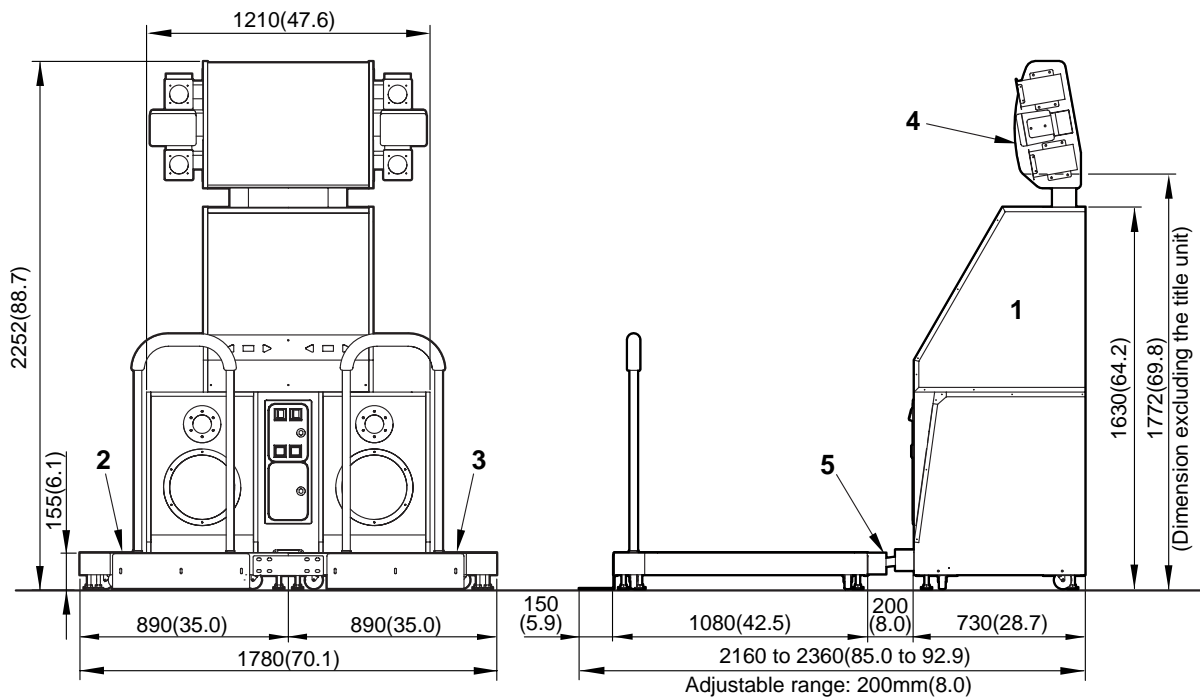

## Specifications

Dimensions	Refer to the figure above : mm (in)	
Weight	Total weight: Approx.437 kg(964 lb) 2 Stage unit (L): Approx.100 kg(220.5 lb) 4 Title unit: Approx.28 kg(61.7 lb)	1 Cabinet unit: Approx.207 kg(456 lb) 3 Stage unit (R): Approx.100 kg(220.5 lb) 5 Unit connection pipe: Approx.2 kg(4.4 lb)
Rated power consumption (actual power)	350W (450VA)	
Monitor	29-inch color monitor	
Service condition	Temperature 5 to 35°C (41 to 95°F), Humidity 30 to 70% (No dewing is allowed.)	
Attachments	<ul style="list-style-type: none"> <li>·Instruction manual ..... This manual</li> <li>·Keys for coin door ..... 2</li> <li>·Keys for maintenance ..... 2</li> <li>·AC power cord ..... 1</li> <li>·Title unit ..... 1</li> <li>·Title unit mounting screw (M6 x 20L) ..... 5</li> <li>·Title unit mounting plain washer (6) ..... 5</li> <li>·Stage plate mounting screw (M6 x 20L) ..... 6</li> <li>·Unit connection pipe ..... 1</li> <li>·Instruction label ..... 1 set</li> <li>·Billboard ..... 1 set</li> <li>·Hexagon wrench (width across flats: 4 mm) ..... 1</li> </ul>	

- If any part is defective or not found, contact your nearest dealer.
- The specifications of this product are subject to change without notice for reasons such as improving the performance.

## ■ Allowance for Carrying-in and Installation of Product — — — — —

The following allowance dimensions are necessary for carrying the product indoors.

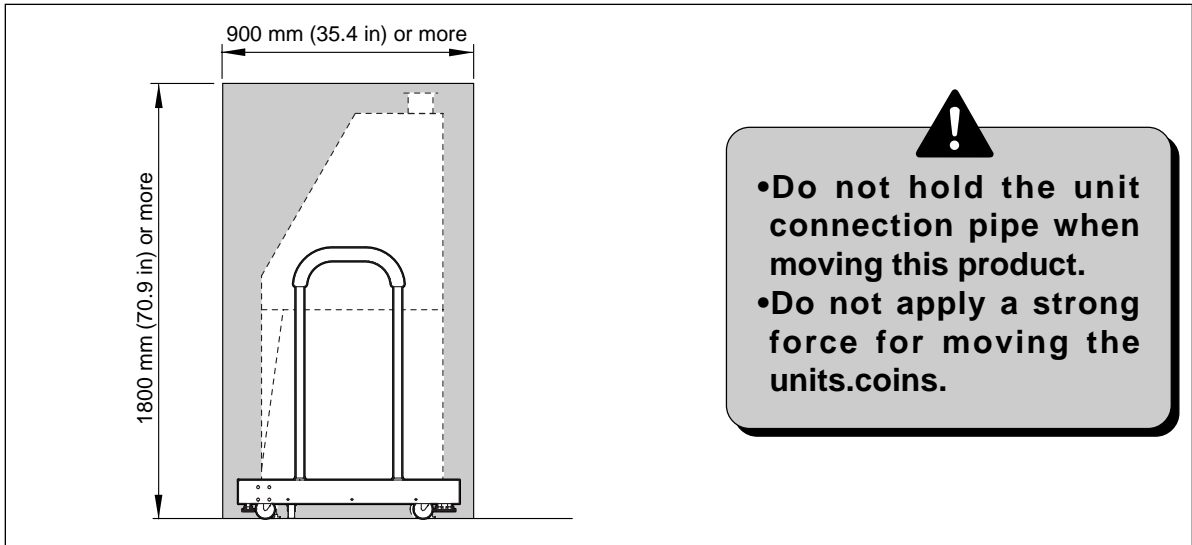

Provide a space of the following dimensions for installation of the product.

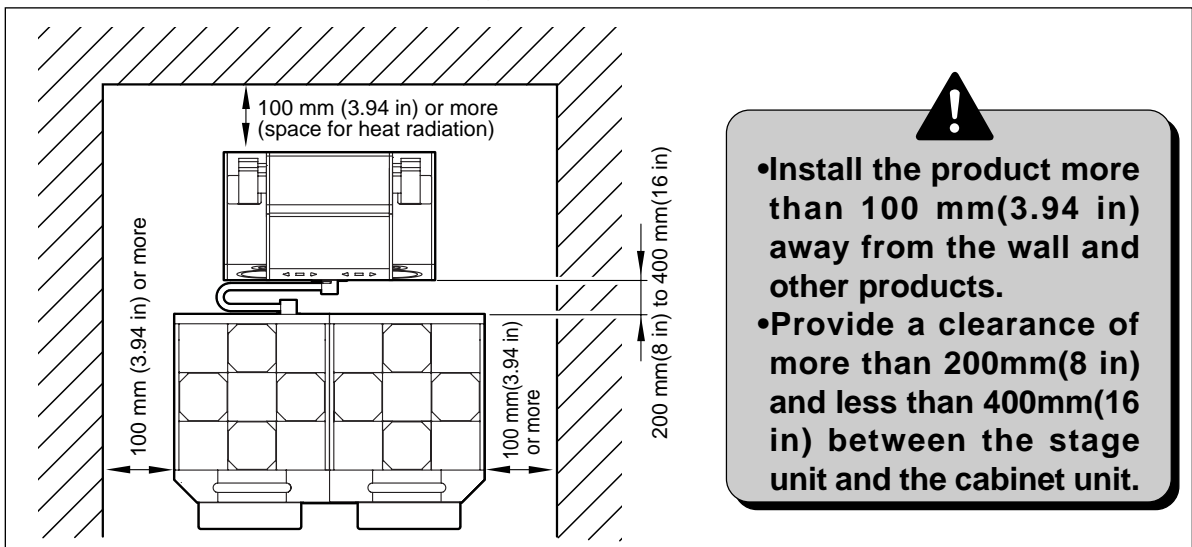

Follow the procedure below when heaving up the product.

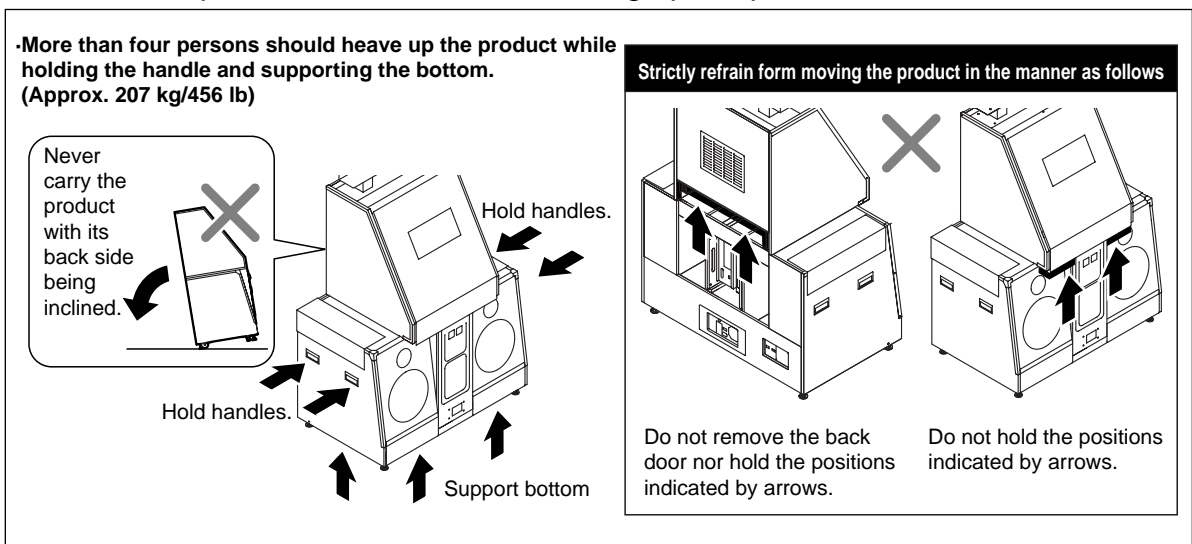

# 2 Names of parts

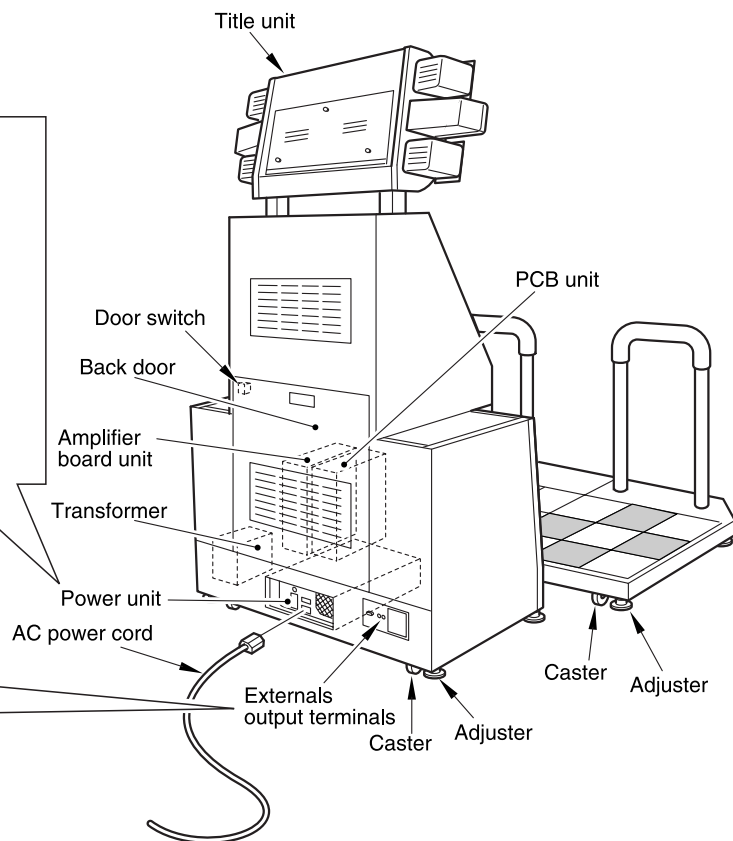
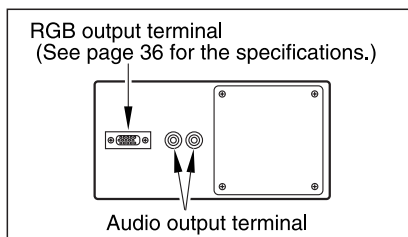
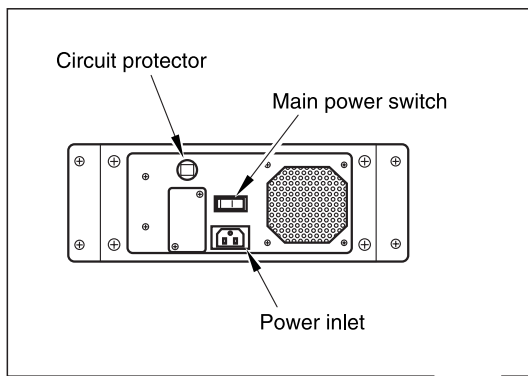
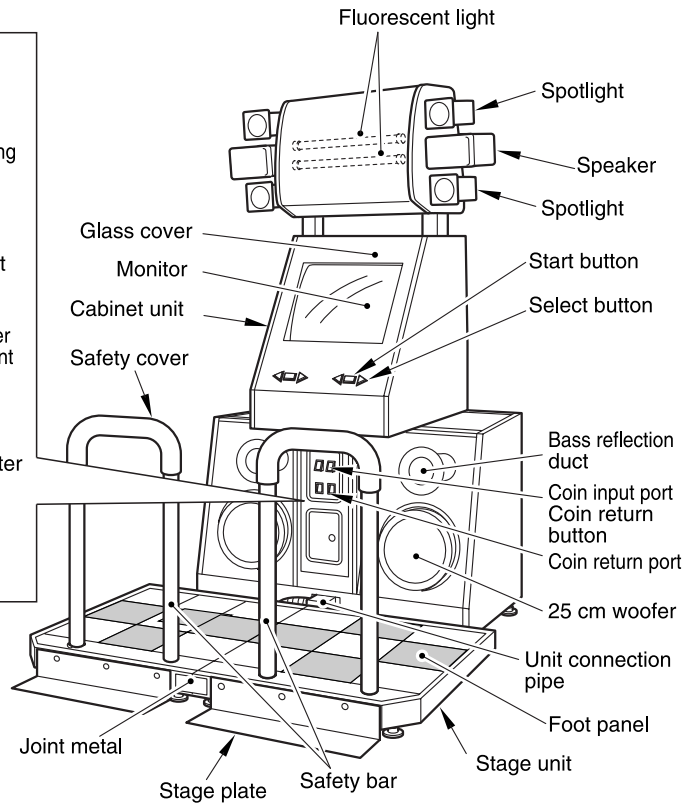
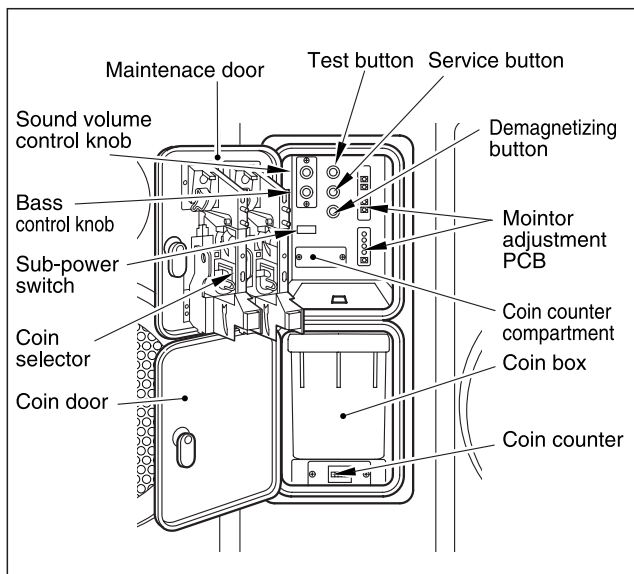



# 4 Opening and closing the doors

## 4-1 Opening and closing the maintenance door

### ■ How to open the maintenance door



- Take care not to apply any load or impact to the maintenance door when it is open.
- After closing the maintenance door, be sure to check that the door is locked securely.

- 1 | Insert the accompanying maintenance key and turn it clockwise.

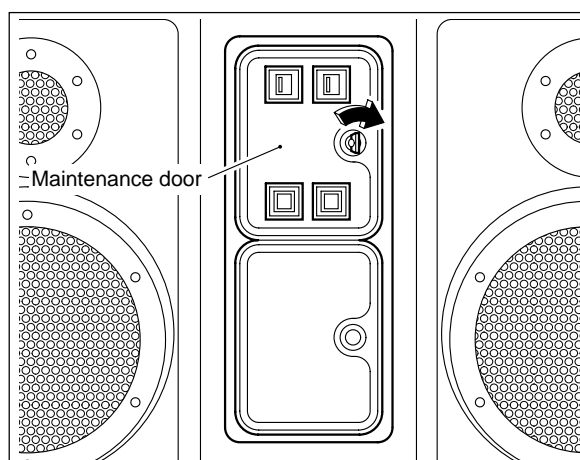

- 2 | Open the maintenance door.

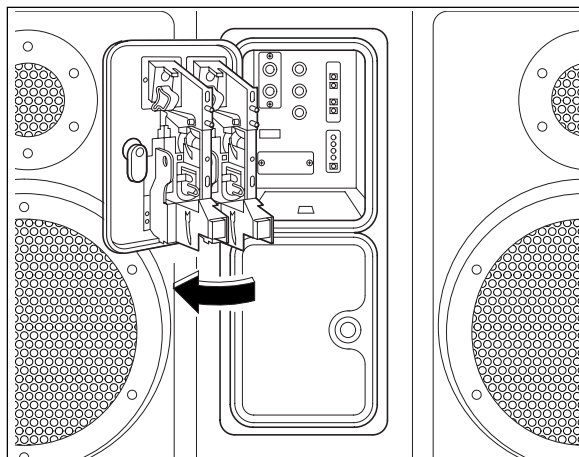

### ■ How to close the maintenance door

- 1 | Close the maintenance door.
- 2 | Turn the maintenance key counterclockwise and draw it out.

## 4-2 Opening and closing the coin door

### ■ Opening and closing the coin door and removing the coin box — — — — —



- Take care not to apply any load or impact to the coin door when it is open.
- Securely lock the door for protection against burglaries.
- Note that the coin box is considerably heavy to take out if it is full of coins.

- 1 | Insert the attached coin door key in the coin door and turn it clockwise.
- 2 | Open the coin door and take out the coin box.

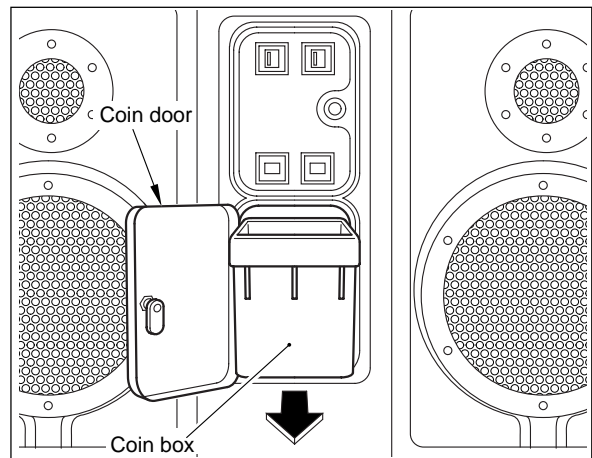

### ■ Coin counter — — — — —

You will find the coin box when the coin door is opened.  
The coin counter is located under the coin box.

• To move the coin counter onto the service panel, see page 39.

**MEMO**

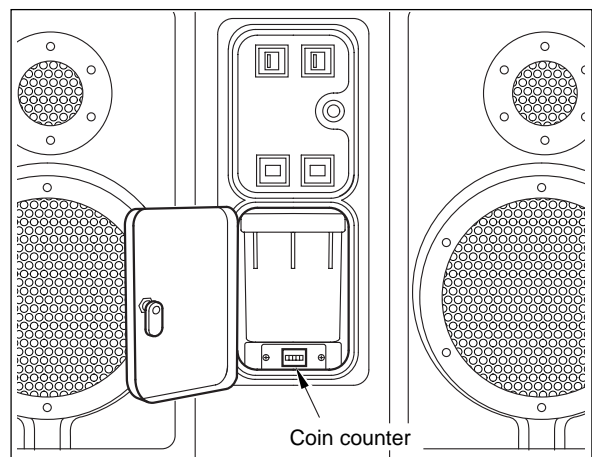

# 5 Game settings

---

## 5-1 Checking the game performance

- When the power switch is turned ON after installation of machine, the performance of game Printed Circuit Boards (PCB) is checked automatically and the result is displayed on the screen. If the power is not turned ON, make sure that the main power switch and sub-power switch are both at the ON position. (See page 35)



- **Be sure to check the PCB unit (self test) before using the machine.**
- **Do not change the DIP switch setting of this product to other than factory setting.**
- **If an abnormality persists or the machine does not operate properly, immediately turn OFF the main power switch, unplug the power cord from the receptacle and contact your nearest dealer.**

### ■ Result of test —————

#### If test is OK

- The machine goes to the game mode and the demonstration game gets started.

#### If any abnormality is detected

- “BAD” appears on the screen, and the checking is repeated.

After the installation of this product or when the PCB unit has been repaired or replaced, turn ON the power switch while pressing the test button of the service panel to initialize the setting once to the original factory setting.

At this time, keep pressing the test button until “RTC DATA INITIALIZED. PLEASE RELEASE TEST BUTTON” appears.

If an abnormal display continues or the machine does not operate normally, immediately turn OFF the main power switch, unplug the power cord and contact your nearest dealer.



## 5-2 Setting and adjustment of game mode

Manually check and change the settings for the screen displays and game contents and change them as required.

### Starting the test mode

- 1 Turn ON the power switch.
- 2 While the demonstration game is playing, press the test button on the service panel. (Do not turn ON the power switch with the test button held down. The current settings will be erased and the machine will have the factory settings.)
  - The main menu is displayed on the screen.

### Quit the manual test mode

- 1 Press the 1P select button (< >) to select "GAME MODE" on the main menu.
- 2 Press the 1P start button.
  - The screen goes back to the game mode.

### Main menu screen (basic items)

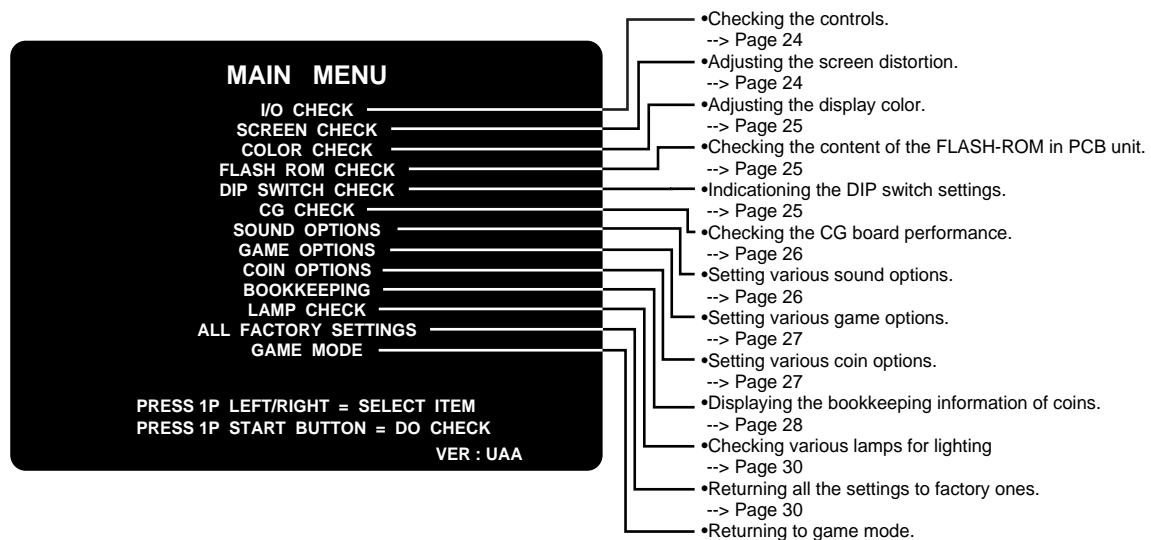

### Selecting each mode

How to select each mode from the main menu

- SELECT --> Press the 1P select button (< >).
- SET --> Press the 1P start button.

After selecting a mode, refer to the page on which that mode is described in details.

## 5-3 Mode descriptions

- The original factory settings are displayed in green; the changed settings are displayed in red.
  - Press the 1P select button to select a mode to be modified. Press the 2P start button to change the setting.
  - After the setting has been changed, select “SAVE AND NEXT” and press the 1P start button for entry.  
“NOW SAVING” will appear, the modified settings will be saved, and the screen returns to the main menu.
  - If “EXIT” is selected after the modification of the settings, the following message will appear.  
“YOU DID NOT SAVE. DO YOU WANT TO SAVE? YES/NO” select “YES” or “NO”. Press either the 2P start button or the select button to select “YES” or “NO”, and press the 1P start button for entry.  
If “YES” is selected, the new settings will be saved with “NOW SAVING” displayed and the screen will return to the main menu.  
If “NO” is selected, the message “NO MODIFICATION” will appear, the modified settings will not be saved, but the main menu will show up again on the screen.

- If “FACTORY SETTINGS” is selected and the 1P start button is pressed, all the setting of the mode will be returned to the factory setting.

**MEMO**

### I/O CHECK

#### Checking the controls

- Mode for checking the performance of buttons and controls.  
To return to the main menu screen, press the 2P start button while pressing the 1P start button.

- There are four footswitches for one panel. The following symbols are displayed in addition to “ON”.
  - L ... Left footswitch is ON.      • R ... Right footswitch is ON.      • U ... Upper footswitch is ON.
  - D... Lower footswitch is ON.      • - ... Footswitch is OFF
- Indication “ON” displayed without stepping on the foot panel may be due to entry of sand or foreign matter in the foot panel. If that is the case, remove it according to the description on page 45.
- If “ON” is still displayed even after the removal of sand or foreign matter, immediately turn OFF the power switch, unplug the power cord and contact your nearest dealer.

**MEMO**

### SCREEN CHECK

#### Adjusting the screen distortion

- Mode for checking the screen display.  
Adjust the focus, distortion and size of the image on the screen while watching the crosshatch pattern. Use the monitor adjustment PCB (See page 48) to make adjustments.  
To return to the main menu screen, press the 1P start button.

## COLOR CHECK

### Adjusting the display color

- Mode for checking the display color.

Make the adjustment using the monitor adjustment PCB (See page 48) so that the colors of the color bars should appear properly graduated and the background should become black sufficiently.

To return to the main menu screen, press the 1P start button.

## FLASH ROM CHECK

### Checking the content of the FLASH-ROM in PCB unit

- Mode for checking the FLASH-ROM. In this mode, the FLASH-ROMs in PCB unit is checked one by one. When a ROM is normal, "OK" is indicated, and if an abnormal ROM is found, "BAD" is indicated.

When the question "DO YOU WANT TO CHECK FLASH ROM ? YES/NO" appears, press the 1P select button to select "YES" or "NO" and press the 1P start button for entry.

When "YES" is selected, FLASH-ROM checking starts automatically. It takes about 40 sec. for checking.

To return to the main menu screen, press the 1P start button. (The game can be interrupted at any time during a play.)

- If "BAD" is indicated, immediately turn OFF the power switch, unplug the power cable and contact your nearby "Konami Service Center".

## DIP SWITCH CHECK

### Indicating the DIP switch settings

- Mode for checking the setting of the DIP switches.

Be sure to set the DIP switches as follows.

To return to the main menu screen, press the 1P start button.

**DIP SWITCH CHECK**

SW	1	2	3	4	OFF
	0	0	0	0	ON

TO MODIFY SETTINGS, OPERATE  
THE RELEVANT DIP SWITCH  
ON THE PCB.

SW1 NOT USE \_\_\_\_\_

SW2 NOT USE \_\_\_\_\_

SW3 NOT USE \_\_\_\_\_

SW4 BOOT DEVICE \_\_\_\_\_  
CD-ROM

PRESS 1P START BUTTON = EXIT

Showing a current position of each DIP switch.  
(The figure shows that all the DIP switches are set to OFF.)

The DIP switch 1 is not used.  
Keep it to OFF.

The DIP switch 2 is not used.  
Keep it to OFF.

The DIP switch 3 is not used.  
Keep it to OFF.

Keep the DIP switch 4 to OFF.  
When it is set to OFF, "CD-ROM" appears on the screen.

- This screen is just an example.

DIP switch bit No.			
1	2	3	4
OFF	OFF	OFF	OFF

- Since the DIP switches have been set in the status shown in figure. at left at the time of shipment, the game starts simply by pressing the power switch. If the bit No. 4 is turned "ON", the game will not start even by pressing the power switch.

**MEMO**

## CG CHECK

### Checking the CG board performance

- Mode for checking the CG board function.  
Check the function of the CG board by watching the motion on the screen in this mode to see if the board works normally or not.  
To return to the main menu screen, press the 1P start button.



The background flows from right below to left above.

Two cubes are engaged each other while rotating.

The left cube is semi-transparent.

## SOUND OPTIONS

### Setting various sound options

- Mode for setting and checking the sound options.  
Press the 1P select button to select an item. Press either the 2P start button or select button to change the setting.  
To return to the main menu screen, select "SAVE AND EXIT" or "EXIT" and press the 1P start button.

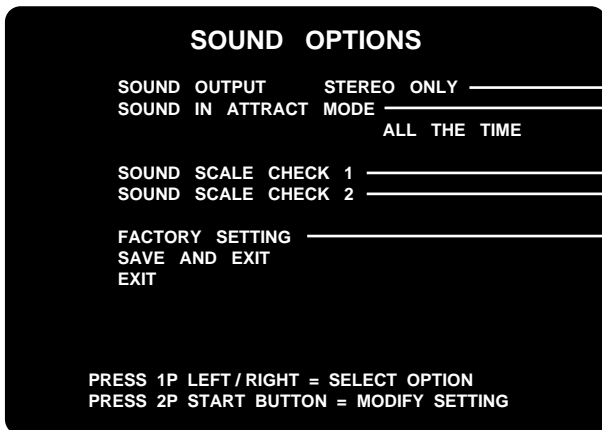

This item can not be selected nor changed.

Turns on and off the demo play sound.  
 ·ALL THE TIME.....Sound always on.  
 ·ONCE EVERY 4 CYCLES.....Sound on every 4 cycles.  
 ·COMPLETELY OFF.....Sound always off.

A balance sound is generated by the built-in sound source. The sound stops when the item ends.

A balance sound is generated by the CD sound source. The sound stops when the item ends.

Press the 1P start button to return all the settings to the factory settings.

•This screen is just an example.

•Control the tone and loudness of sound by the sound volume control knob and the bass control knob provided on the service panel. (Refer to page 35.)

**MEMO**

## GAME OPTIONS

### Setting various game options

- Mode for setting and checking the game options.  
Press the 1P select button to select an item. Press either the 2P start button or select button to change the setting.  
To return to the main menu screen, select "SAVE AND EXIT" or "EXIT" and press the 1P start button.

**GAME OPTIONS**

DIFFICULTY LEVEL 4 / MEDIUM  
 MAX STAGE 3  
 GAME OVER DURING SONG OFF  
 SHOW INSTRUCTION ON

FACTORY SETTING  
 CLEAR HIGH SCORE  
 SAVE AND EXIT  
 EXIT

PRESS 1P LEFT / RIGHT = SELECT OPTION  
 PRESS 2P START BUTTON = MODIFY SETTING

- Sets a difficulty level (from the 8 levels).  
 1/EASIEST .....Easier  
 2/VERY EASY  
 3/EASY  
 4/MEDIUM .....Standard  
 5/MEDIUM HARD  
 6/HARD  
 7/VERY HARD  
 8/HARDEST .....Harder
- Setting the number of stages (1-3) to be played.
- Setting whether or not the game is played till the end of a music number, when the dance gauge indicates "zero".  
 ON.....makes the game continue till the end of a music number.  
 OFF.....makes the game end.
- Sets whether "How to play" is shown before the game or not.  
 ON.....shows it.  
 OFF.....does not show it.
- Press the 1P start button to return all the settings to the factory settings. (High score is not cleared.)
- Clears the high scores in all stages.

•This screen is just an example.

## COIN OPTIONS

### Setting various coin options

- Mode for setting and checking the coin options.  
Press the 1P select button to select an item. Press either the 2P start button or select button to change the setting.  
To return to the main menu screen, select "SAVE AND EXIT" or "EXIT" and press the 1P start button.

**!**

•The coin setting options are not displayed when "FREE PLAY" is set to "ON".  
In such case, remember the games will be free.

**COIN OPTIONS**

FREE PLAY OFF  
 COIN SLOT 1 3 COINS 1 CREDIT  
 COIN SLOT 2 3 COINS 1 CREDIT

JOINT GAME PREMIUM OFF

FACTORY SETTING  
 SAVE AND EXIT  
 EXIT

PRESS 1P LEFT / RIGHT = SELECT OPTION  
 PRESS 2P START BUTTON = MODIFY SETTING

- Selects a free play.  
 ON.....Available for free play.  
 OFF.....Not available for free play.
- Sets the number of credits for the coin.  
 (1 coin 7 credits - 16 coins 1 credit)
- Sets whether a credit is required for the 2P to join the play or not when the 1P player gets the premium play right.  
 ON.....does not require a credit for 2P.  
 OFF.....requires a credit for 2P.
- Press the 1P start button to return all the settings to the factory settings.

•This screen is just an example.

## BOOKKEEPING

### Displaying the bookkeeping information of coins

- Mode for displaying the total data on the number of coins put in the machine.

If the time is preset on the “CLOCK SETUP” screen, the total data on the number of coins put into the machine can be checked for each coin slot.

To return to the main menu screen, select “SAVE AND EXIT” or “EXIT” and press the 1P start button.

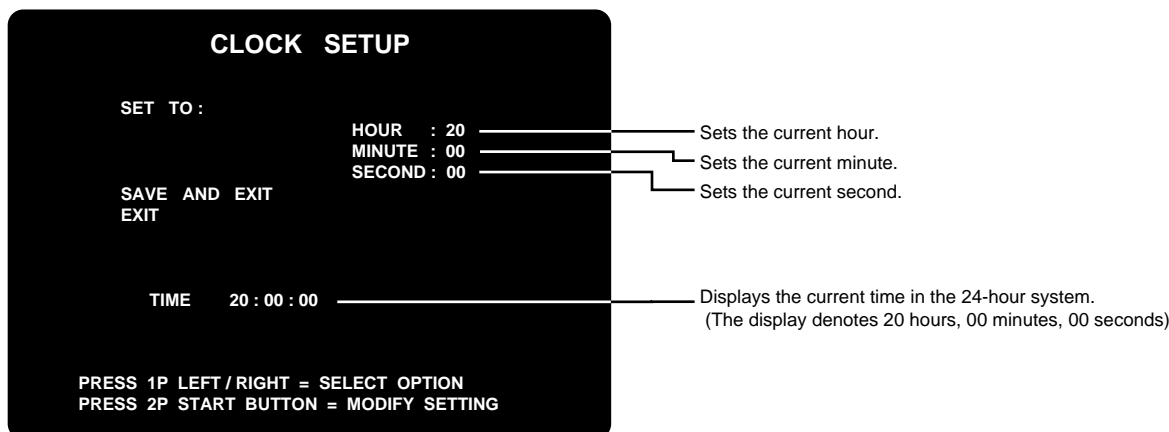

•This screen is just an example.

- If the time setting has not been made — for example, after the machine has been set up or initialized —, the “CLOCK SETUP” screen shows up.
- When the time setting has been modified, the bookkeeping information is automatically cleared. With the current time not set, the total of received coins and other bookkeeping data are not displayed. (The data once erased can not be resumed.)

### MEMO

- When the time has been preset on the “CLOCK SETUP” screen as shown above, the following “VIEW BOOKKEEPING INFORMATION” is displayed on the screen. When the 1P select button is pressed, the screen changes as follows.

To return to the main menu screen, press the 1P start button in individual display screen.

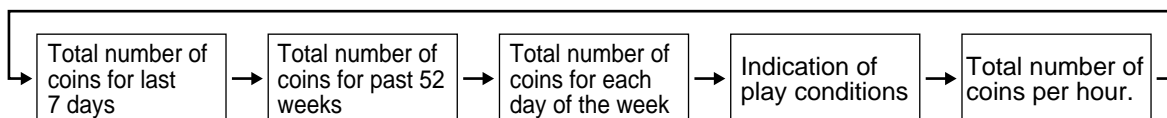

Also, when the current time has been set and the 2P start button is pressed in each screen, the current time and bookkeeping data can be cleared.

At this time, the question “DO YOU WANT TO CLEAR ALL BOOKKEEPING DATA? YES/NO” is indicated on the screen. Then, press the 1P start button to select “YES” or “NO”.

If “YES” is selected, the question for re-confirmation appears on the screen. If “YES” is selected again, all the bookkeeping data are deleted and “CLEAR BOOKKEEPING” appears on the screen, the data is saved as was set at the time of shipment and the main menu appears again automatically.

If “NO” is selected, “NO MODIFICATION” is indicated and the main menu appears again without deletion of the data.



**Screen of the total number of coins per hour.**

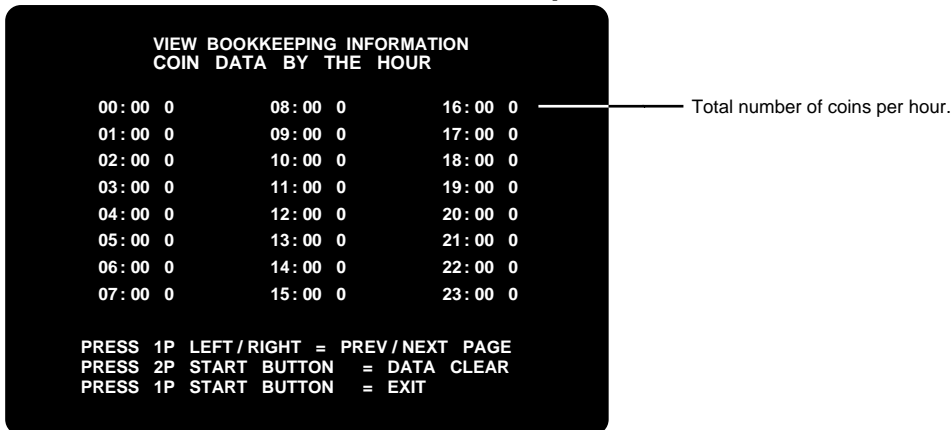

•This screen is just an example.

## LAMP CHECK

**Checking various lamps for lighting**

- Mode for checking various button and control indicators for lighting.  
Press the 1P select button to select a lamp to be lighted and press the 1P start button. (The lamp lights up as long as the button is pressed.) If “ALL” is selected, all the lamps light up one after another.  
To return to the main menu screen, select “EXIT” and press the 1P start button.

## ALL FACTORY SETTINGS

**Returning all the settings to factory ones**

- Mode for returning all the settings to the factory settings at the time of shipping.  
Press the 1P select button to select “YES” or “NO”, and press the 1P start button for entry.  
If “YES” is selected, the question for re-confirmation appears on the screen. If “YES” is selected again, the “NOW SAVING” message appears on the screen and all the data of settings in test mode are saved as was set at the time of shipment and the main menu appears again automatically.  
If “NO” is selected, “NO MODIFICATION” is indicated and the main menu appears again without saving the data of changed settings.

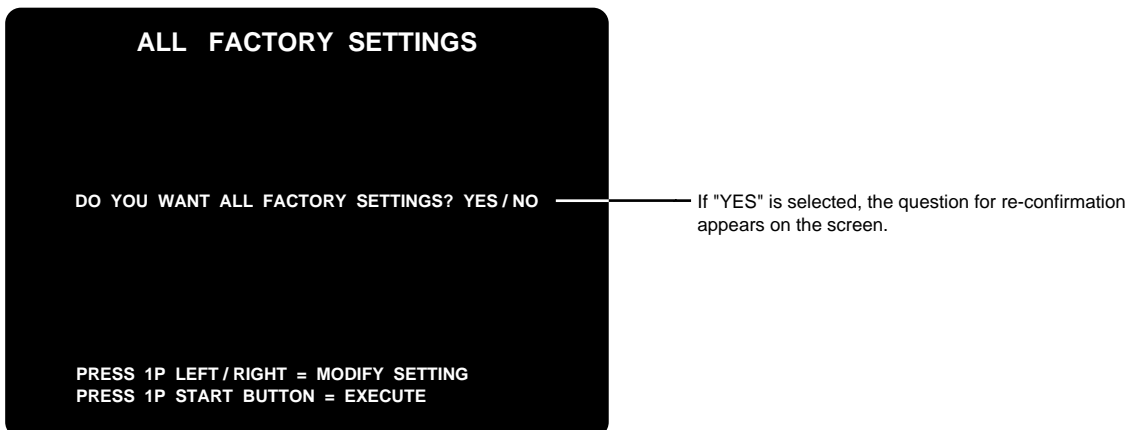

•This screen is just an example.



# 6 Installation and assembling

## 6-1 Connection of units

### ■ How to connect the stage units



- Do not apply a strong force for moving the stage units after connection.
- Never move the stage units across a step after connection.
- Pay full attention not to pinch wires in the connection of the stage units.

- 1** Remove plates shown in the figure from the stage units.
- 2** Remove safety bar fixing bolts from the stage units.
- 3** Use the bolts removed to fix the stage units.
- 4** Reinstall the plates removed in step 1 above.
- 5** Remove the joint metals mounted to the stage units.
- 6** Remove the stage plates mounted to the cabinet unit.
- 7** Connect the connectors which link the right and left stage units.
- 8** Connect the right and left stage units at two points with the joint metals removed in step 5 above.

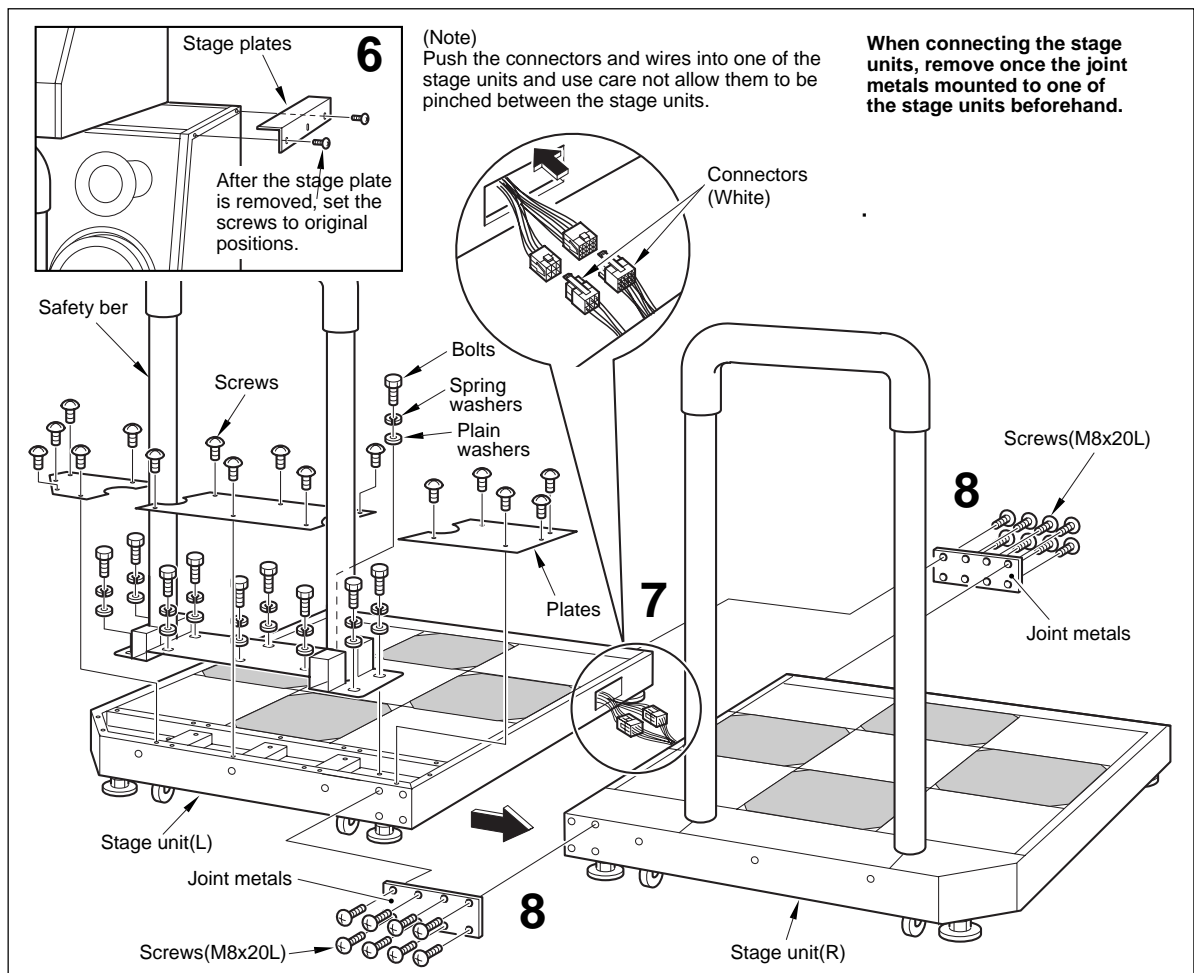

■ How to connect the stage units and cabinet units — — — — —



- Do not hold the unit connection pipe for moving the units.
- Do not apply a strong force for moving the units after connection.
- Do not move the units across a step after connection.
- Pay full attention not to pinch the wires when connecting the units.
- Provide a clearance of more than 200 mm(8 in) and less than 400 mm(16 in) between the stage units and the cabinet units.

- 1** Remove the screws fixing the unit connection pipe mounted to the stage units.
- 2** Connect the connectors extended from the stage units to the connectors of unit connection pipe, paying attention not to confuse their colors.
- 3** Fix the unit connection pipe to the stage units with use of the screws which have been removed in step 1 above.
- 4** Connect the connectors extended from the cabinet unit to the connectors of unit connecting pipe.
- 5** Fix the unit connection pipe to the cabinet unit with the screws which have been removed in step 1 above.

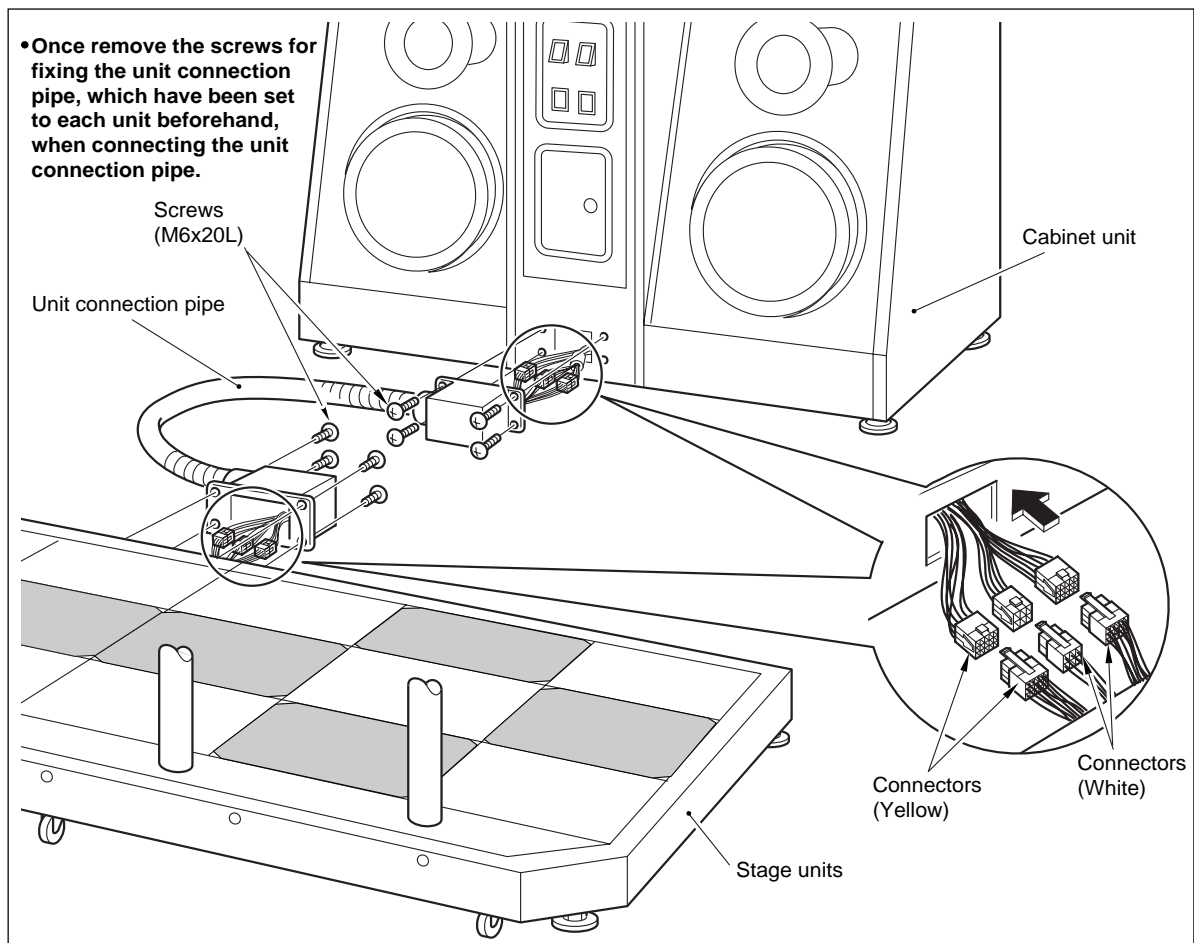

## How to mount the title unit



- Before mounting the title unit, be sure to fix the units by adjusters. (See the description of 6-2. Fastening the adjusters on page 34.)
- The title unit weighs 28 kg approx. Be sure to carry out the mounting work by three persons or more, using a stepladder for safety sake.
- Pay full attention not to allow your hand or wires to be pinched while mounting the title unit.

- 1 Fix each of the units with adjusters by referring to the description of “6-2. Fastening the adjusters” on page 34.
- 2 Place the title unit on the cabinet unit and fix it by tightening the plain washers and screws for title unit mounting by means of the accompanying hexagon wrench.

- Do not hold the units by speakers and spotlights.
- Pay attention not to pinch the wires.

### MEMO

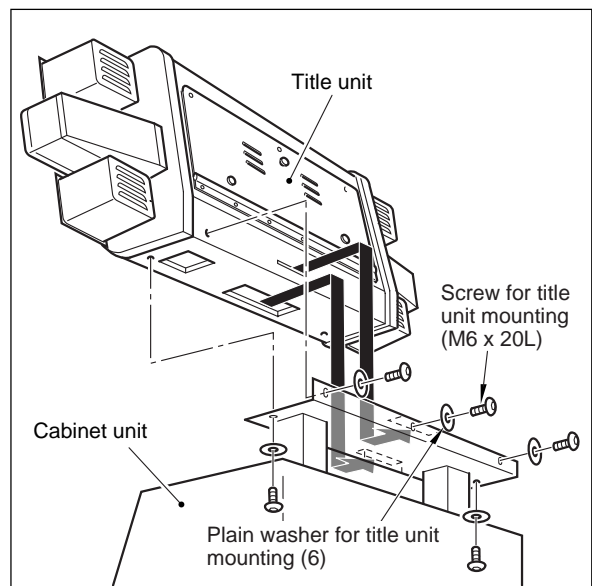

- 3 Open the title unit cover, pull out the connector from the bottom opening of the cabinet unit and connect them. (See page 41 for how to open the title unit cover.)

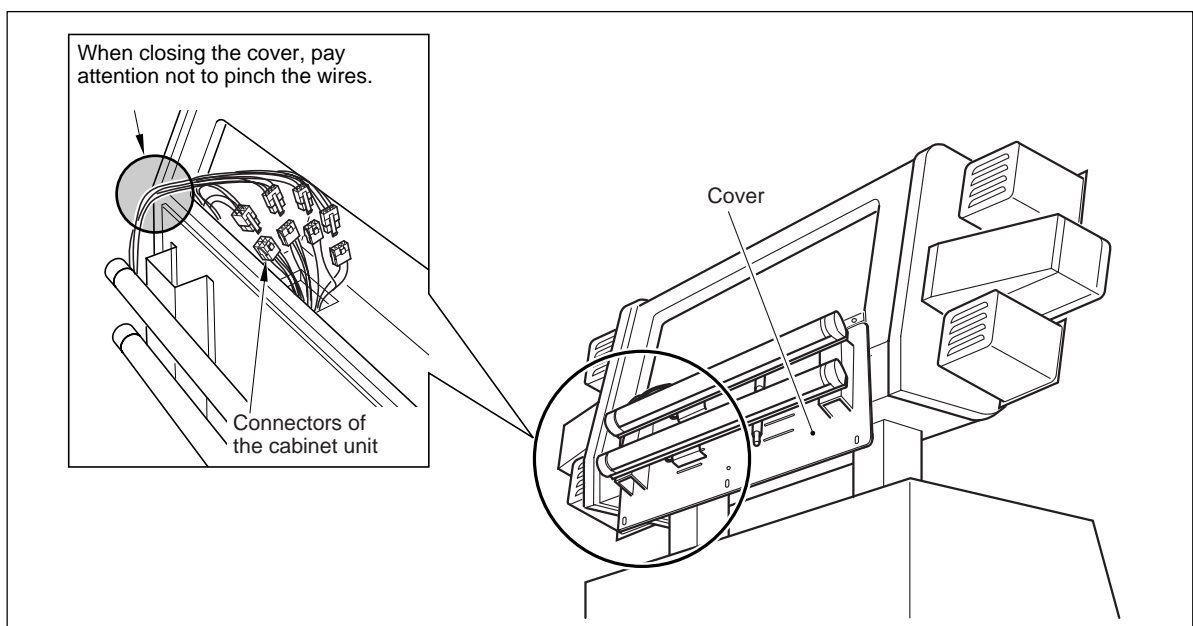

■ How to mount the stage plates



- Be sure to mount the stage plates which effectively prevent the stage unit from lifting.
- Mount the stage plate after the fixation of adjusters of each unit.

Mount the stage plates, which have been removed in step 2 on page 31, with the accompanying screws.

- Mount the stage plate after the completion of the fixation described in “6-2. Fastening the adjusters”.
- Be sure to remove the stage plates when moving the units.

**MEMO**

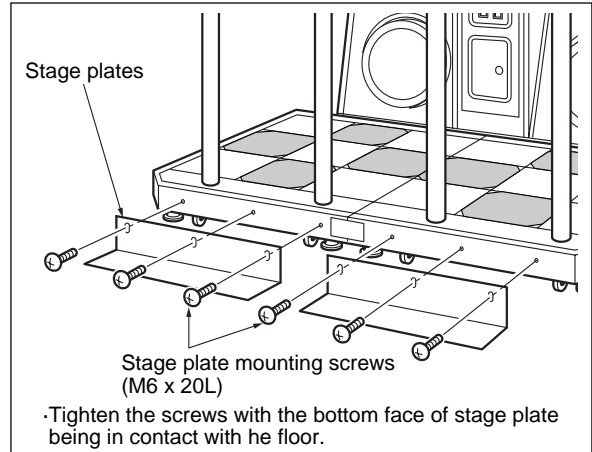

## 6-2 Fastening the adjusters

■ How to fasten the adjusters



- After the connection of the units, make all the adjusters contact the floor.
- Adjust the adjusters so that the casters do not touch the floor. Take care not to exceed the maximum adjusting height of the adjuster.
- Make all the 12 adjusters come in contact with the floor, tighten them with hexagon nuts after making sure that all the units are placed stably in a horizontal position.

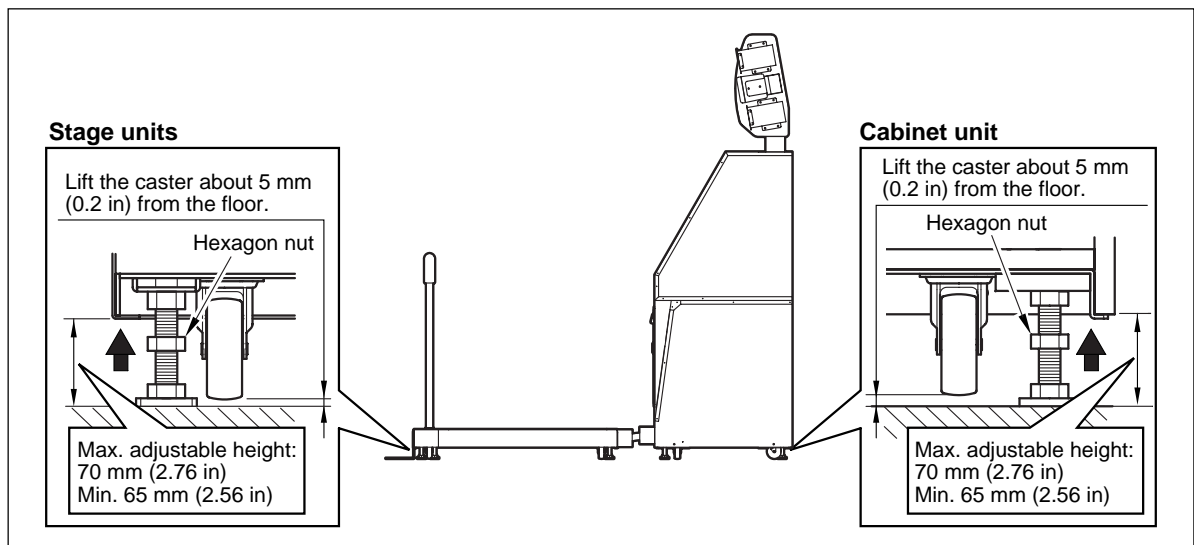

## 6-3 Power unit

### Power unit

The power supply unit is provided at the rear side of the cabinet unit.



- Be sure to use the attached AC power cord.
- Be sure to ground to the machine. Never connect the grounding wire to gas pipe, water pipe or telephone ground terminal.
- There are high-voltaged parts inside the product. Other persons than qualified industry specialist should not open the back door. When the back door is opened, pay due attention not to touch the inside unnecessarily.
- If the sub power switch of the service panel is turned OFF without turning OFF the main power switch of the power supply unit, some parts in the units remain live. When opening the back door, be sure to turn OFF the main power switch and unplug the power cord from the receptacle.

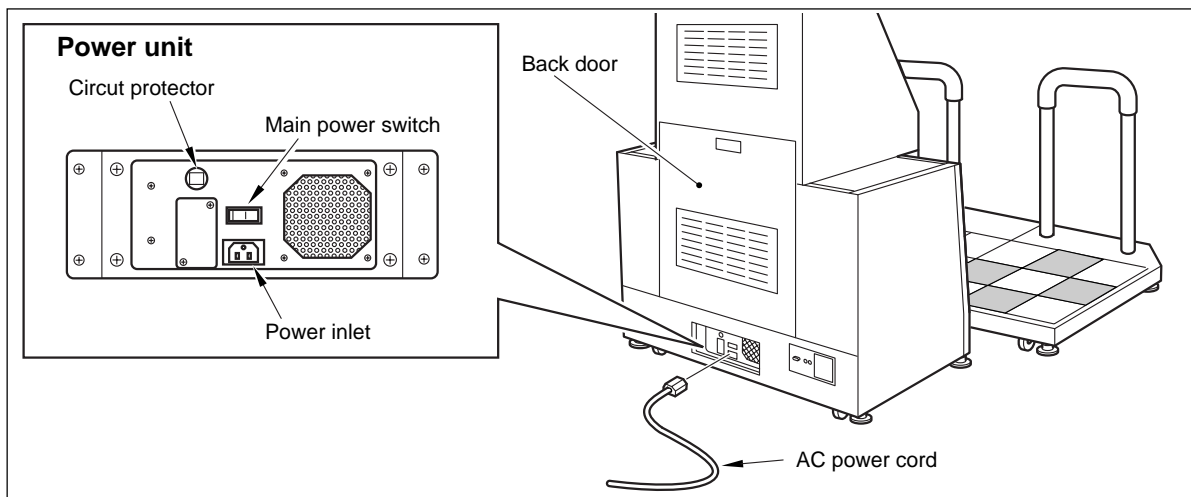

## 6-4 Service panel

### Service panel

Using the accompanying maintenance key, open and detach the maintenance door to access the service panel inside.

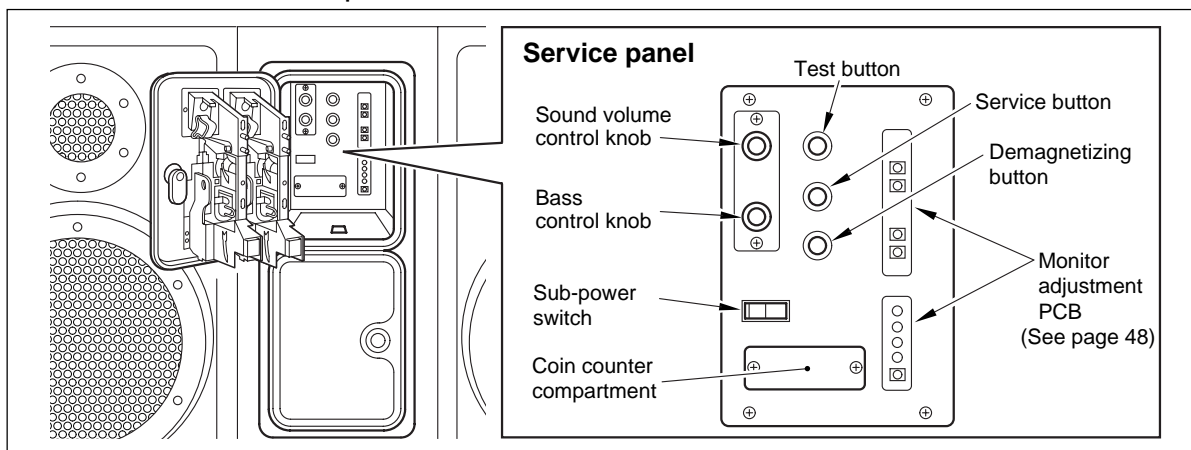

## 6-5 External output terminals

### External output terminals

For video output and audio output from this product, the external output terminals are provided at the rear side of cabinet.

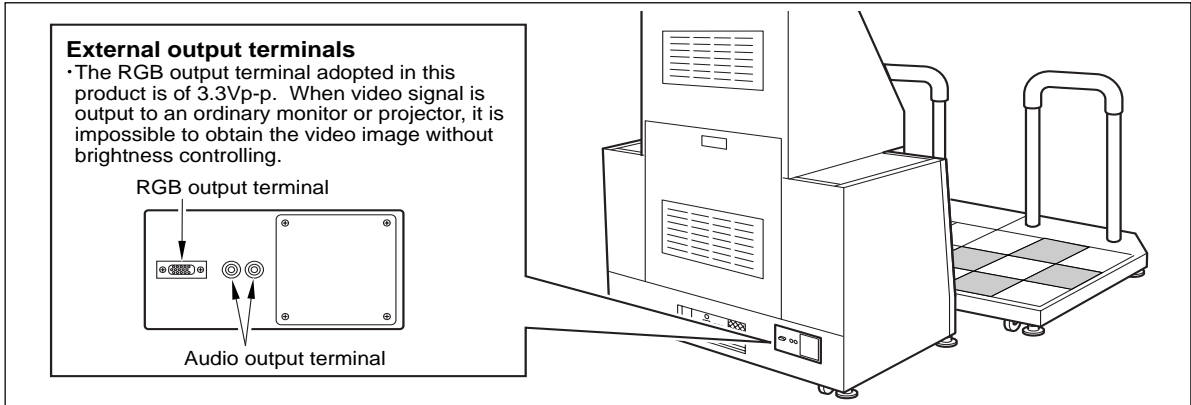

### Specification of RGB output terminal

When outputting the video image to an external projector etc. through this RGB output terminal, be sure to check the external equipment to be connected to this terminal to see if its specification is compatible with the specification of the terminal. The RGB output terminal outputs the RGB signal of 3.3Vp-p video signal amplitude for a video game monitor CRT of composite SYNC specification. Accordingly, if this signal is input by a monitor CRT for personal computer etc. of 0.7Vp-p amplitude, horizontal/vertical separation SYNC input specification, such monitor CRT will not work normally or cause a trouble with the equipment.

Please refer to the tables below as for the specifications of the RGB terminal.

#### Shape

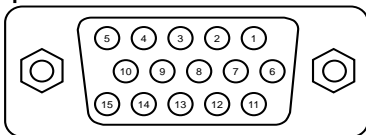

15-pin Mini Dsub (conforming to MIL-C-24308 Standard) (Female)

#### Video signal output specification

Horizontal sync.frequency	15.8kHz
RGB video signal level	3.3Vp-p
RGB video signal terminal	High impedance
Sync. signal level	TTL level
Sync. signal system	Composite

#### Arrangement

1	RED	6	GND	11	
2	GREEN	7	GND	12	
3	BLUE	8	GND	13	C-SYNC
4		9		14	
5		10	GND	15	

#### Video signal timing

	Horizontal sync.	Vertical sync.
Sync. frequency	15.8kHz	59.8Hz
A = Non-display section	16 $\mu$ s	38 lines
B = Display section	47.8 $\mu$ s	224 lines
C = Sync. signal amplitude	3.81 $\mu$ s	2 lines
D = Front porch	3.69 $\mu$ s	12 lines
E = Back porch	8.5 $\mu$ s	24 lines

#### Video signal timing chart

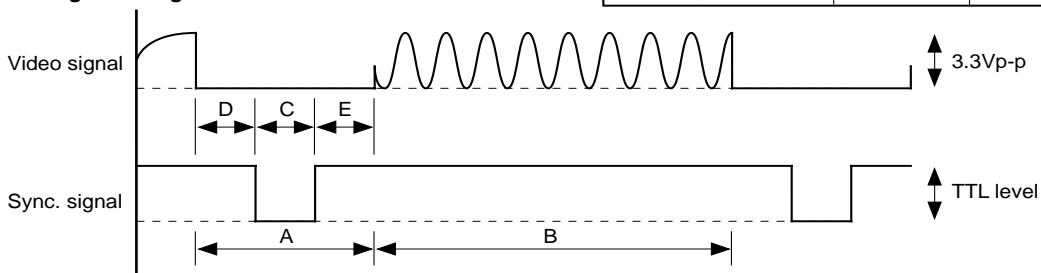

### The specifications of audio output terminal



Audio output level	0 $\pm$ 6dB
Output impedance	2k $\Omega$

# 6-6 Mounting billboards

## ■ Mounting billboards —————

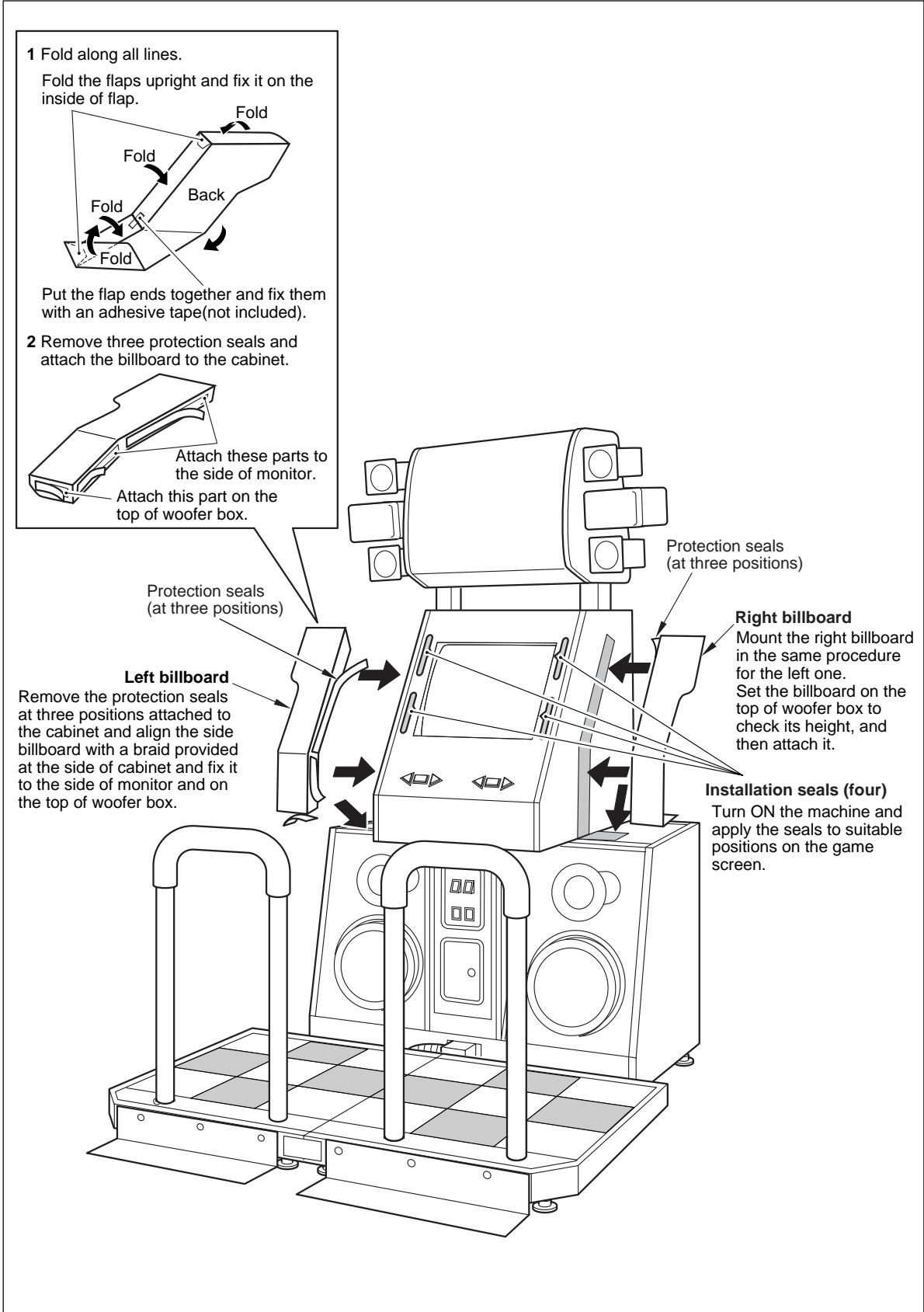



## 6-7 Splitting into and moving of units

### ■ How to split into units

This product can be split into individual units.



- Before splitting the product, be sure to turn OFF the main power switch and unplug the power cord from the receptacle.
- When moving this product, be sure to split it into the stage units, cabinet unit and unit connection pipe and remove connectors.
- If it is necessary to separate the title unit from the cabinet unit, split them before loosening the adjusters.
- Fully lift up the 12 adjusters before moving the product. Use casters to move it.
- When connecting the split units again, pay due attention not to pinch your hand and wires.

- 1** Turn OFF the main power switch and unplug the power cord from the receptacle.
- 2** Split the stage units from the cabinet units in the reverse of connection. (See page 32.)
- 3** Remove the stage plates mounted to the stage units. (See page 34.)
- 4** Loosen the 12 adjusters and move the units on casters. It is necessary to dismount the title unit, dismount it before loosening the adjusters.

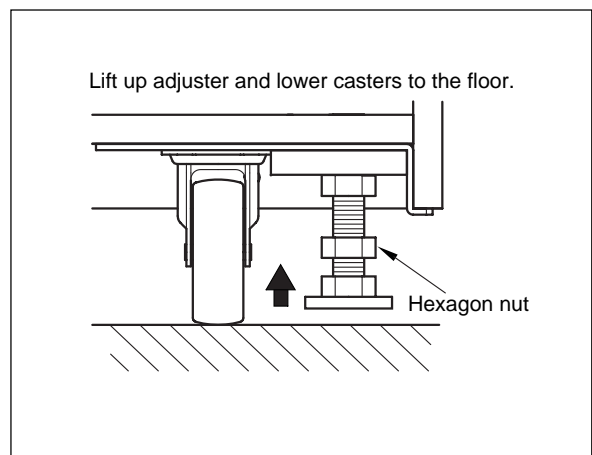
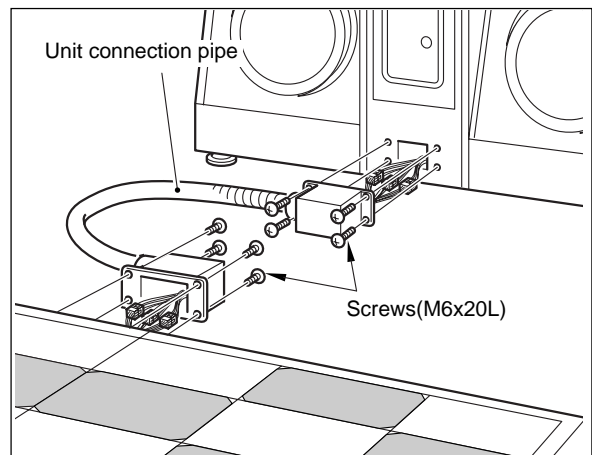



## 6-8 Moving the coin counter

### ■ How to move the coin counter —————

The coin counter was installed in the coin box when the machine left the factory, but it can be moved onto the service panel.



•Before moving the coin counter, be sure to turn OFF the main power switch and unplug the power cord from the receptacle.

**1** Be sure to turn OFF the main power switch and unplug the power cord from the receptacle.

**2** Open the coin door, remove the screws and take out the coin counter. In the meanwhile, disconnect the connector.

**3** Remove the maintenance door and unscrew the blind cover to remove it from the service panel.

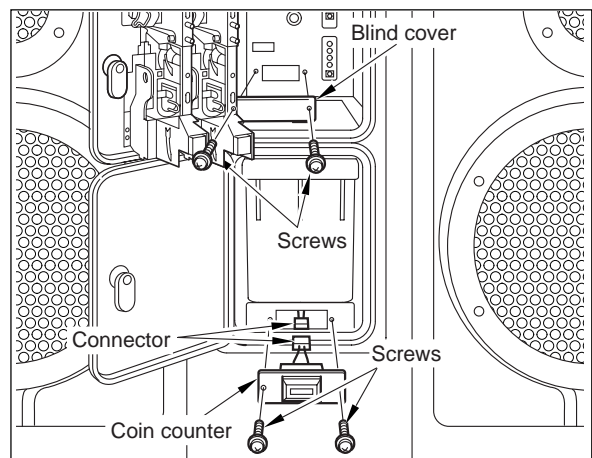

**4** Draw the connector out of the opening of the service panel and connect this connector to the coin counter's connector.

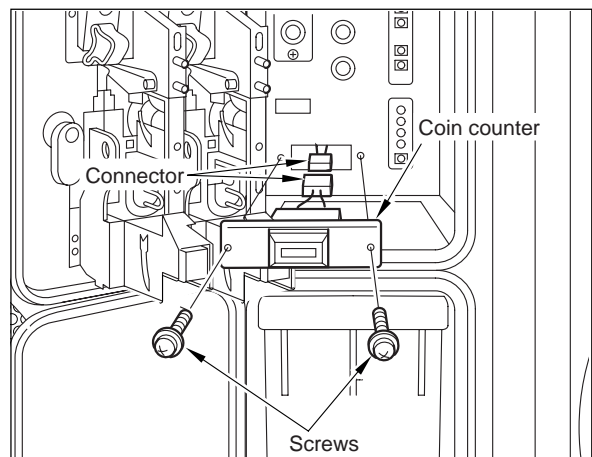

**5** Attach the coin counter on the service panel with the screws.

**6** Attach the blind cover (detached in Step 3 above) back in position on the coin counter using the screws.

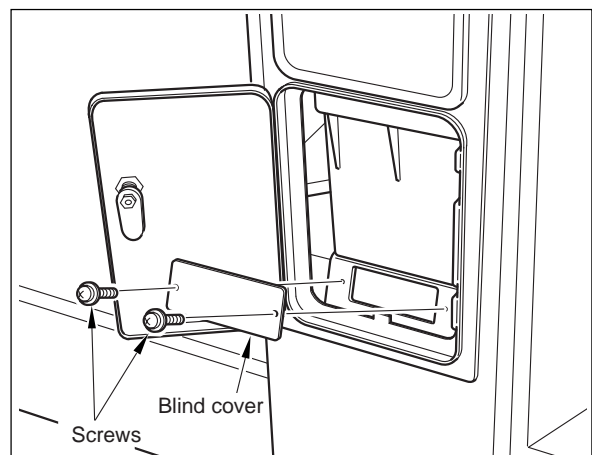

# 7 Maintenance

## 7-1 Replacing the coin selector

### ■ How to replace the coin selector



- Before replacing the coin selector, be sure to turn OFF the main power switch and unplug the power cord from the receptacle.
- When replacing parts, be sure to use parts of the correct specifications. Never use parts other than the specified ones.
- Strictly refrain from disassembly and repair of parts which are not indicated in this manual, as well as settings and remodelling.

**1** Be sure to turn OFF the main power switch and unplug the power cord from the receptacle.

**2** Open the maintenance door and remove two bolts as shown in figure which fix the coin selector.

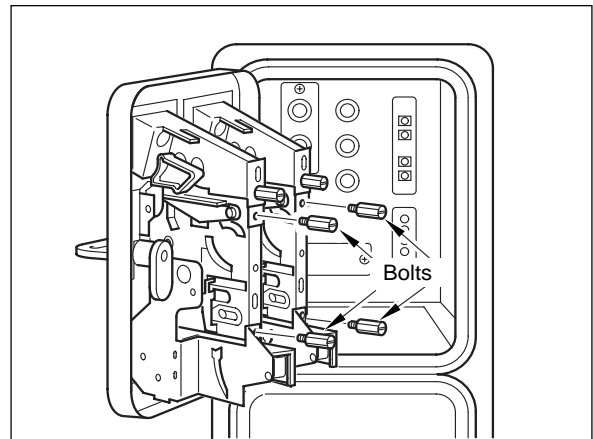

**3** Release the levers that fix the coin selector. See at right.

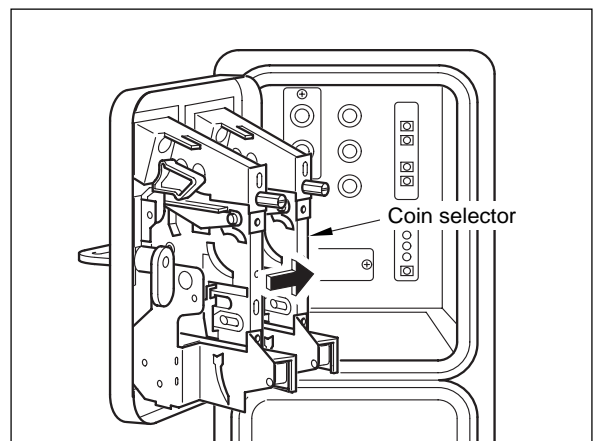

**4** **To fit the coin selector again**  
While holding up the white lever, mount a new coin selector by sliding it toward the left.

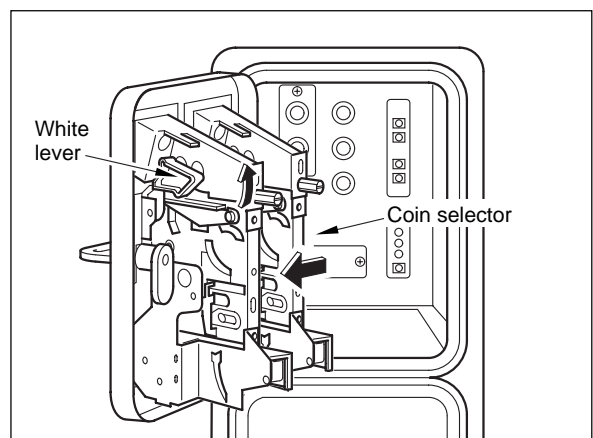

**5** After fixing the bolts which have been removed in step 2, close the maintenance door.

## 7-2 Replacing the fluorescent light

### ■ How to replace the fluorescent light



- Before replacing the fluorescent light, be sure to turn OFF the main power switch and unplug the power cord from the receptacle.
- Open and close the fluorescent light cover gently.
- The fluorescent light is hot just after the power switch is turned off. Wait until it cools down and then replace it with a new one of the same type (straight tube 20W / 100V).
- When replacing parts, be sure to use parts of the correct specifications. Never use parts other than the specified ones.
- Strictly refrain from disassembly and repair of parts which are not indicated in this manual, as well as settings and remodelling.

**1** Be sure to turn OFF the main power switch and unplug the power cord from the receptacle.

**2** Remove the screws off the cover, and hold the knob and gently open the cover.

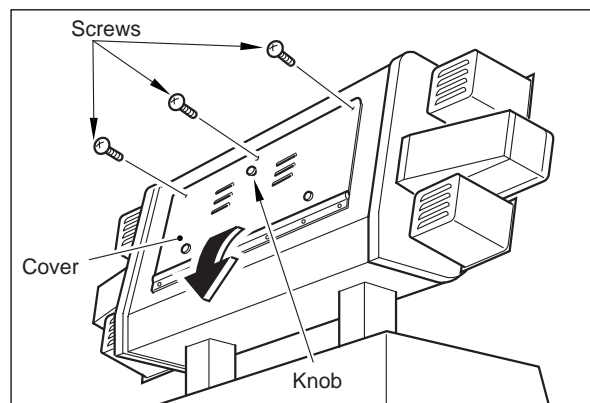

**3** Push one end of the fluorescent light in the direction of the socket. The other end of the fluorescent light will be detached from the opposite socket.

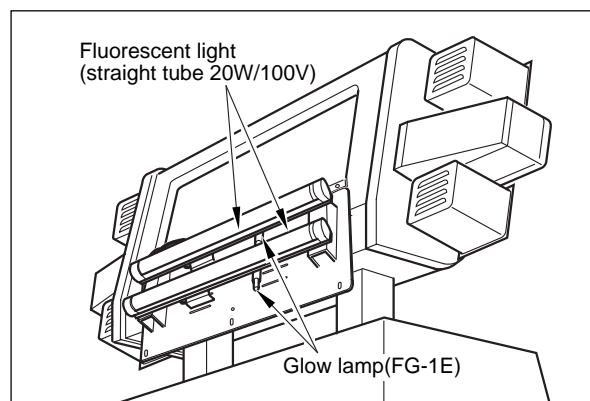

**4** Install a new fluorescent light in the reverse order and close the cover.

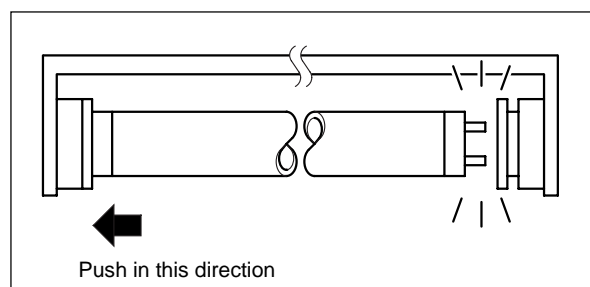

• It is recommended to replace the glow lamp at the same time.

**MEMO**

## 7-3 Replacing the spotlight lamp

### ■ How to replace the spotlight lamp



- Before replacing the halogen lamp, be sure to turn OFF the main power switch and unplug the the power cord from the receptacle .
- The halogen lamp is still very hot immediately after the power switch is turned off. Make sure that it is sufficiently cooled before replacement work.
- When replacing parts, be sure to use parts of the correct specifications. Never use parts other than the specified ones.
- Strictly refrain from disassembly and repair of parts which are not indicated in this manual, as well as settings and remodelling.

- 1 Be sure to turn OFF the main power switch and unplug the power cord from the receptacle.
- 2 Remove the screws and detach the lamp covers.
- 3 Remove the halogen lamps.
- 4 Mount a new halogen lamp in the reverse of removal.
- 5 Attach the lamp covers as it was.

- Upper lamp covers: Red
- Lower lamp covers: Green

### MEMO

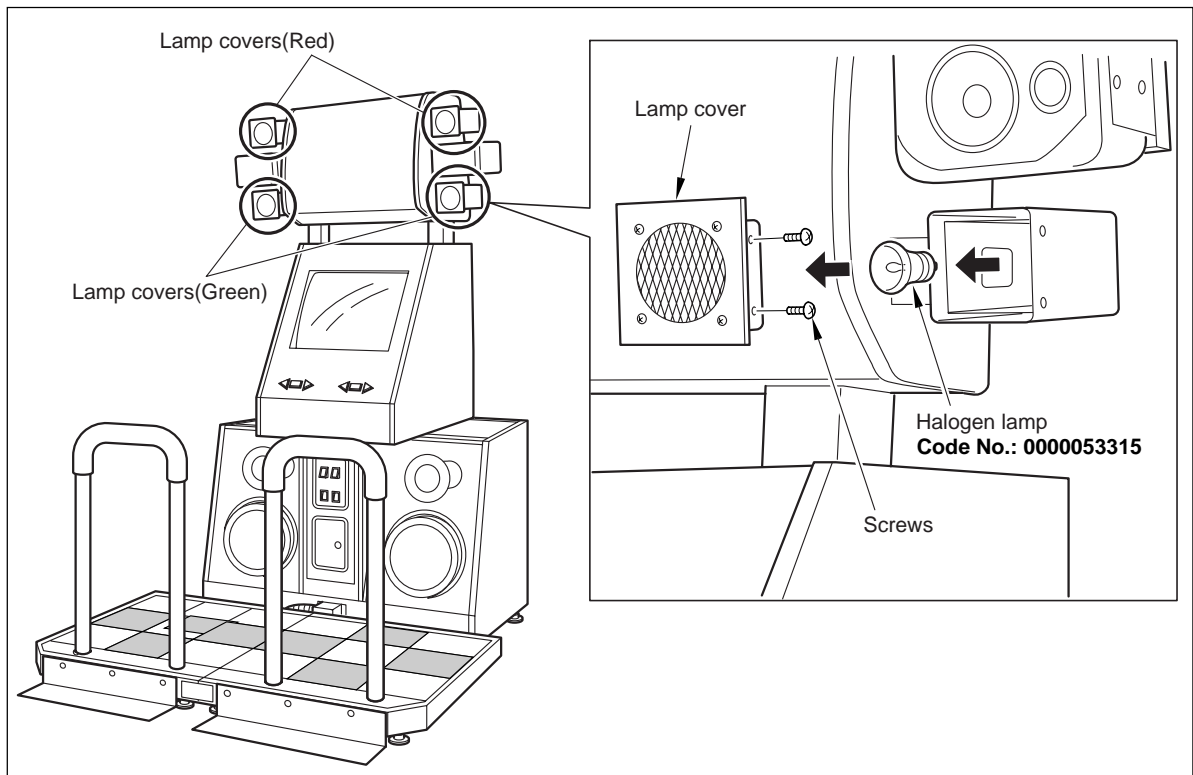

## 7-4 Replacing the button

### ■ How to replace the button



- Before replacing the button, be sure to turn OFF the main power switch and unplug the power cord from the receptacle.
- When replacing parts, be sure to use parts of the correct specifications. Never use parts other than the specified ones.
- Strictly refrain from disassembly and repair of parts which are not indicated in this manual, as well as settings and remodelling.

**1** Be sure to turn OFF the main power switch and unplug the power cord from the receptacle.

**2** Remove the screws and lift the panel.

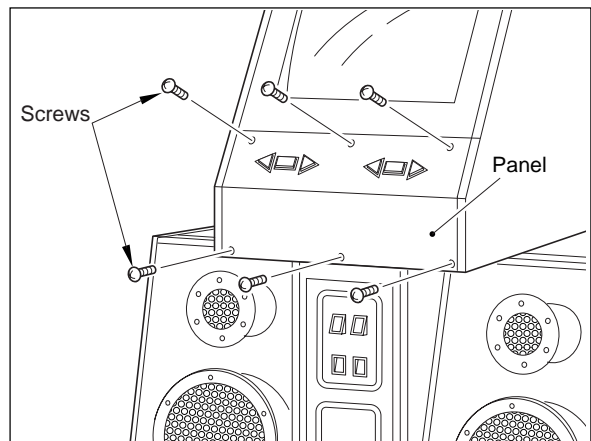

**3** Disconnect the connectors and dismount the panel.

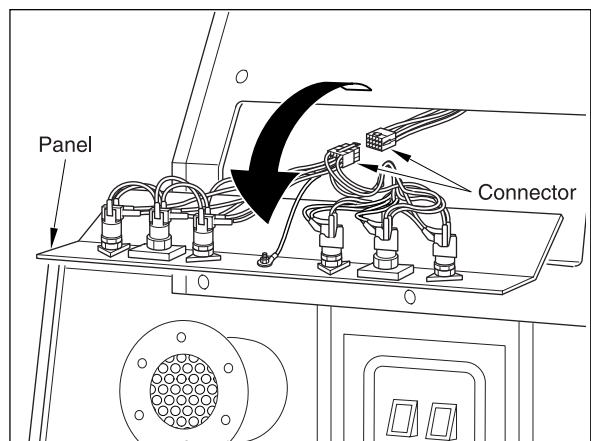

**4** Pull out the sockets from the buttons.

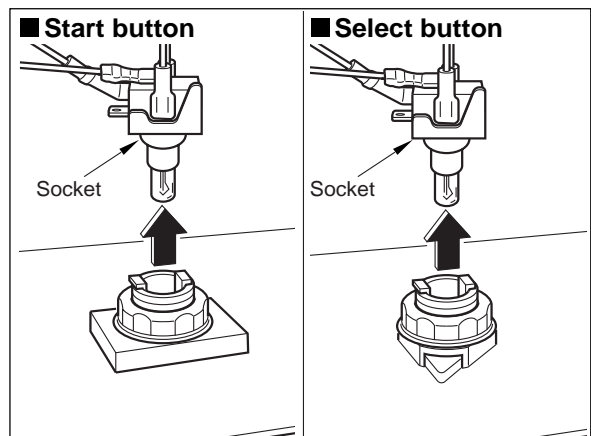

- 5** Loosen the nuts and separate the button.

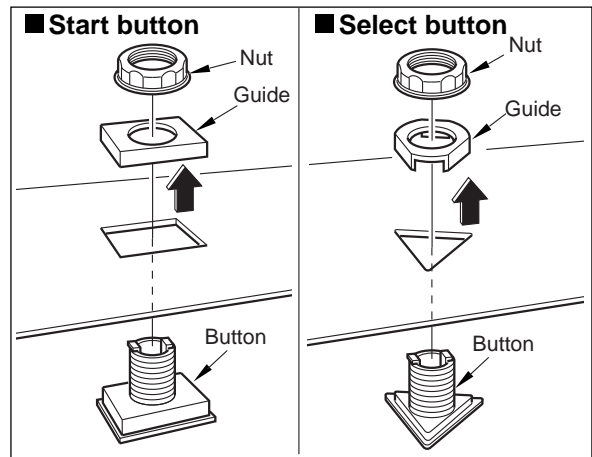

- 6** **To fit the button again**  
Set the buttons so that the projections at the back side of buttons should fit into the holes of panel and fix them by nuts.

- 7** Pay attention to the posture of buttons, and sockets and assemble them in the reverse of disassembly, using care not to confuse the wires. Pay attention not to pinch the wires when mounting the panel to the cabinet unit.

•Posture of plugs as viewed from the back of panel

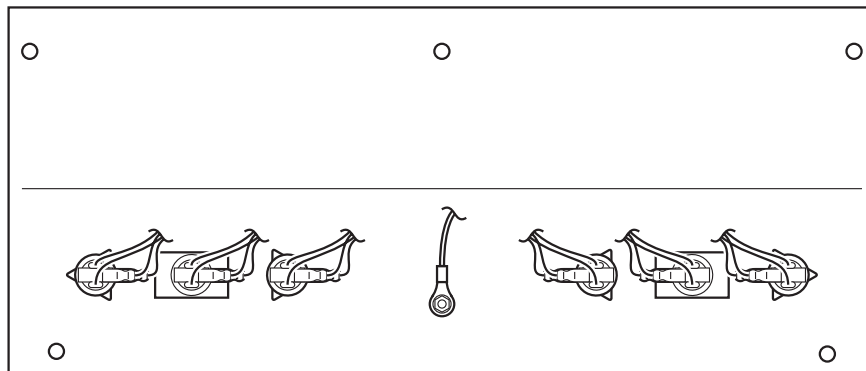

•After replacement of socket and lamp

After the replacement of socket, connect the wires in the manner as shown below.

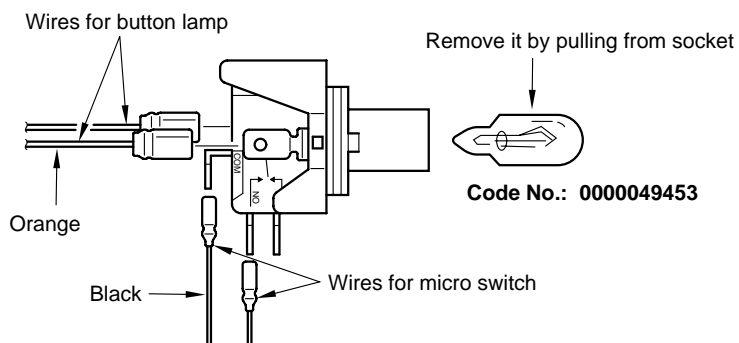

**MEMO**

## 7-5 Maintenance of foot switch

### ■ Maintenance of foot switch



- Before replacing the foot switch, be sure to turn OFF the main power switch and unplug the power cord from the receptacle.
- The stage units is so constructed that foreign matters such as sand etc. easily enter the clearance between the foot panel and the corner metals or the inside of the foot panel. Therefore, check it once a day, and if any foreign matter exists, detach the foot panel and remove it by brush or vacuum cleaner.
- Do not apply fats such as wax etc. to the top surface of the stage units including the foot panel. Otherwise, a player may tumble down by slipping to get injury.
- Do not wipe the foot panel (acrylic resin plate) with thinner or alcohols.
- When replacing parts, be sure to use parts of the correct specifications. Never use parts other than the specified ones.
- Strictly refrain from disassembly and repair of parts which are not indicated in this manual, as well as settings and remodelling.

**1** Be sure to turn OFF the main power switch and unplug the power cord from the receptacle.

**2** Remove the corner metals which fix the foot panel and dismount the foot panel.

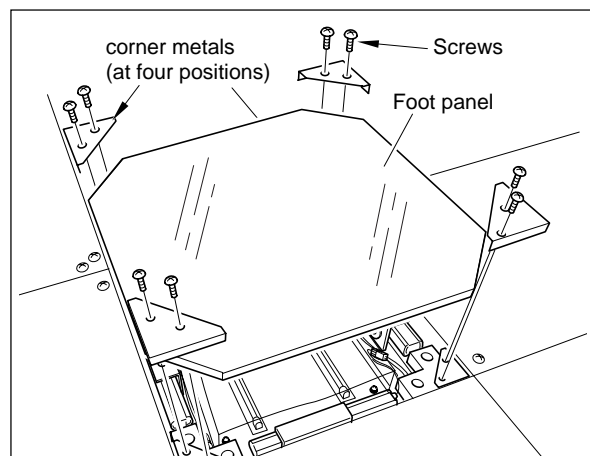

**3** Pull out the connectors and remove the screws which fix the lamp unit.

**4** Take out the lamp unit.

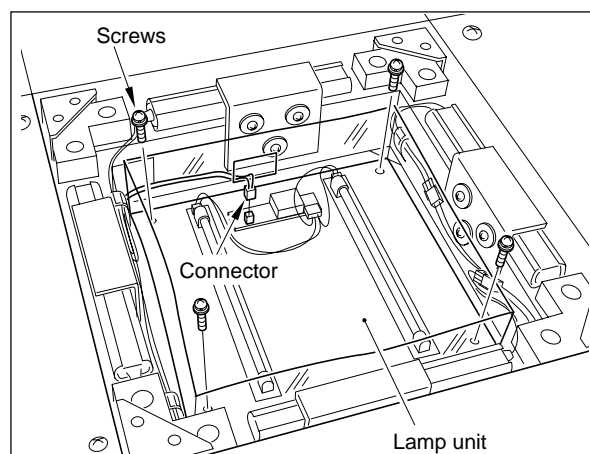



**5** Cut off the band which is binding wires and pull out one foot switch connector.

**6** Remove the bracket which holds the foot switch.

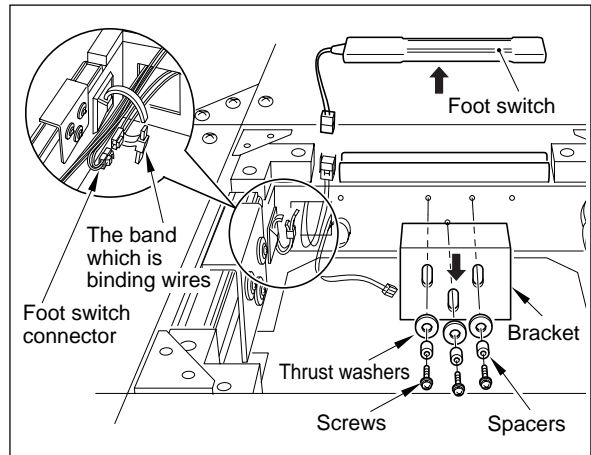

**•Do not mount the thrust washers in wrong direction.**

Direct the Teflon-coated part of the thrust washer to the bracket side.

**MEMO**

**7** Mount the foot switch in the reverse of dismantling.

**•Pay attention to the following points when mounting the foot switch.**

- When setting the foot plate, pay attention not to pinch the wires.
- It is normal that the bracket can be moved even when the screws is tightened firmly.
- Connect the connector through the opening of the transparent cover.

**•Pay attention to the foot panel setting direction.**

	R				R
B		B		B	
	R			R	

- Arrange the lamp units in the same direction as shown.
- Pay attention to the lamp unit setting position which differs depending on its color.
- "R (Red)" or "B (Blue)" is printed on the inverter PCB.

**•Pay attention not to pinch or tread the wires when setting the lamp unit.**



## 7-6 Resetting the circuit protector

### ■ How to reset the circuit protector

If an overcurrent or short circuit occurs, the circuit protector will be automatically actuated to protect the electric circuits of the game machine. When resetting the circuit protector, turn OFF the main power switch, unplug the power cord from the receptacle, eliminate the cause, and then press the button of the circuit protector.



- Before resetting the circuit protector, be sure to turn OFF the main power switch and unplug the power cord from the receptacle.
- If the circuit protector trips soon again, immediately turn OFF the main power switch, unplug the power cord, and contact your nearest dealer.
- There are high-voltaged parts inside the product. Other persons than qualified industry specialist should not open the back door. When the back door is opened, pay due attention not to touch the inside unnecessarily.
- If the sub power switch of the service panel is turned OFF without turning OFF the main power switch of the power supply unit, some parts in the units remain live. When opening the back door, be sure to turn OFF the main power switch and unplug the power cord from the receptacle.
- If the machine is in abnormal conditions and does not operate normally, immediately turn OFF the main power switch, unplug the power cord from the receptacle and contact your nearest dealer.

- 1 Be sure to turn OFF the main power switch and unplug the power cord from the receptacle.
- 2 Remove the cause of the trouble. Press the button on the circuit protector of the power unit.

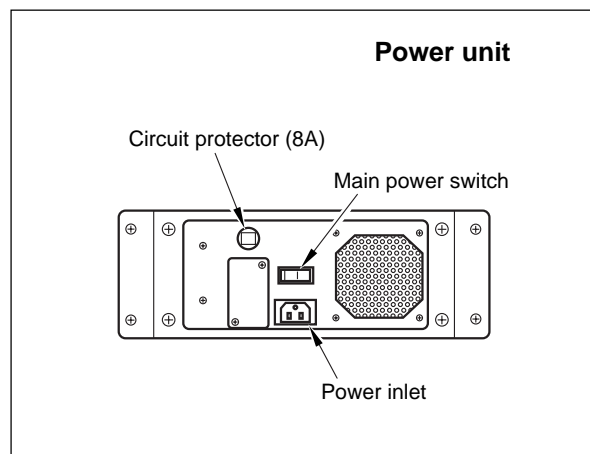

## 7-7 Adjusting the monitor

### ■ Monitor adjustment PCB

The monitor has already been adjusted at the time of shipment, but it may be readjusted as desired.

The monitor adjustment PCB is located inside the service panel. When adjusting the monitor, open the maintenance door. (See page 20)

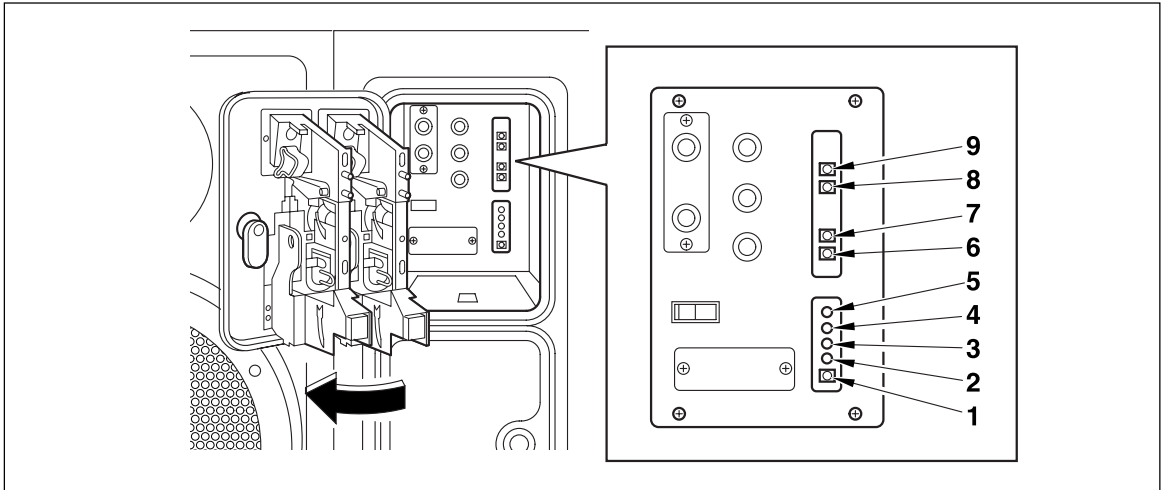

1	<b>CONTRAST</b>	<b>Contrast adjustment</b> Used to changes the contrast.
2	<b>R.GAIN</b>	<b>Red input gain adjustment</b> Changes red brightness. Turning it clockwise will make the red deeper.
3	<b>G.GAIN</b>	<b>Green input gain adjustment</b> Changes green brightness. Turning it clockwise will make the green deeper.
4	<b>B.GAIN</b>	<b>Blue input gain adjustment</b> Changes blue brightness. Turning it clockwise will make the blue deeper.
5	<b>BRIGHT</b>	<b>Brightness adjustment</b> Changes brightness. Turning it clockwise will make the image brighter.
6	<b>H.SIZE</b>	<b>Horizontal screen size adjustment</b> Changes the width of the screen.
7	<b>H.POSI</b>	<b>Horizontal image position adjustment</b> Changes the image position in the horizontal direction.
8	<b>V.SIZE</b>	<b>Vertical screen size adjustment</b> Changes the height of the screen.
9	<b>V.POSI</b>	<b>Vertical image position adjustment</b> Changes the image position in the vertical direction.

# 8 Annex

## 8-1 Label locations and exploded view

■ Label —————

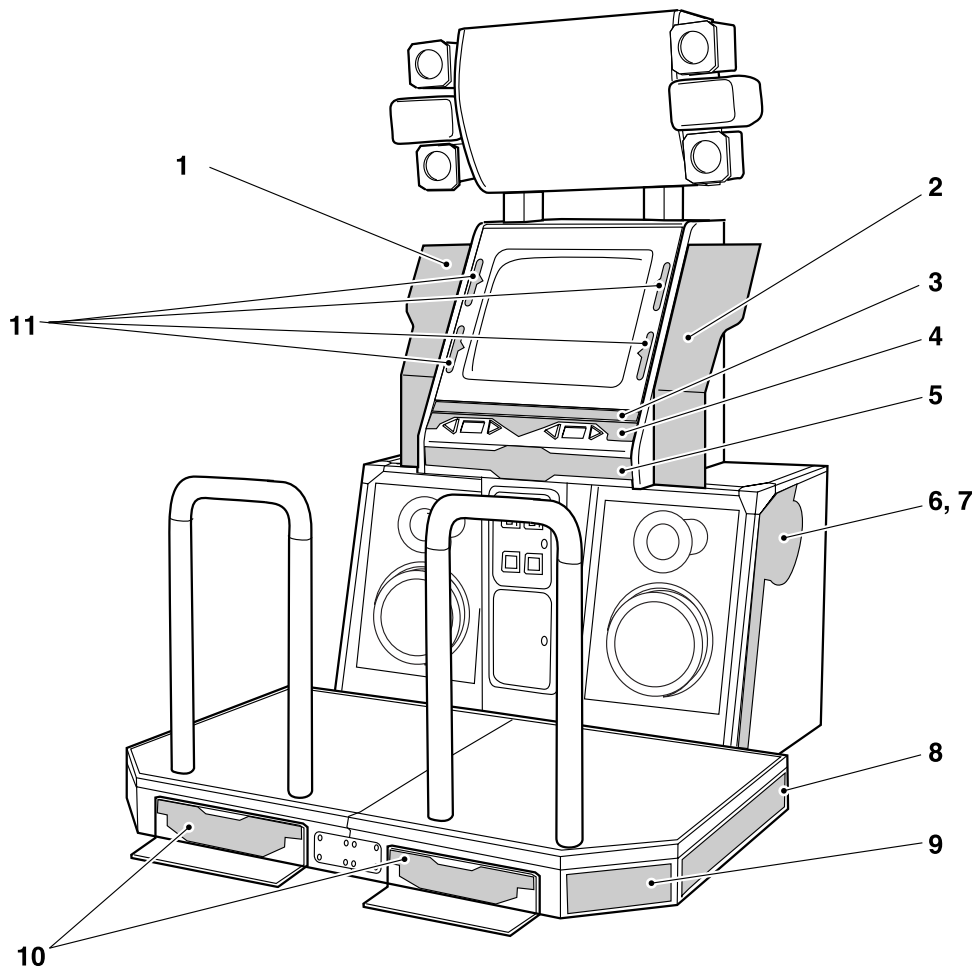

No.	CODE No.	NAME	QTY	NOTE
1	0000059045	P O P	1	LEFT SIDE
2	0000059046	P O P	1	RIGHT SIDE
3	0000053387	LABEL, CONTROL C	1	
4	0000059038	LABEL, CONTROL B	1	
5	0000053158	LABEL, CONTROL A	1	
6	0000053152	LABEL, SIDE /L	1	
7	0000053154	LABEL, SIDE /R	1	
8	0000053157	LABEL, STEP C	2	
9	0000053156	LABEL, STEP B	2	
10	0000053155	LABEL, STEP A	2	
11	0000059047	LABEL, INST/HD	1	

FIG.1 UNIT, CABINET(1/4)

NO.	CODE NO.	NAME	SPEC. /CATALOG TYPE	QTY	NOTE
1	0000054009	CABINET, MAIN		1	
2	0000052885	BRACKET, ADJUSTER		4	
3	0000054015	COVER, EDGE		1	
4	0000054017	COVER, EDGE		1	
5	0000053980	COVER, EDGE		1	
6	0000054018	COVER, EDGE		1	
7	0000054023	COVER, EDGE		1	
8	0000054028	COVER, EDGE		1	
9	0000046280	PLATE, COIN		1	
51	0000047156	CASTER	TCM-75NM	4	
52	0000061705	ADJUSTER	16*92*75	4	

NO.	CODE NO.	NAME	SPEC. /CATALOG TYPE	QTY	NOTE
101		SCREW, CROSS PAN SEMS	M6x25/MFZn2-C	8	PW, SW
102		SCREW, CROSS PAN SEMS	M6x15/MFZn2-C	16	PW, SW
103		SCREW, CROSS TRUSS	M6x25/BLACK	8	
104		SCREW, CROSS TAPPING TRUSS	4x12/MFCr	18	
105		BOLT, CAP SQUARE NECK	M4x25/MFZn2	5	
106		NUT, FLANGE	M4/MFZn2-C	5	
107		SCREW, CROSS TRUSS	M6x20/BLACK	4	

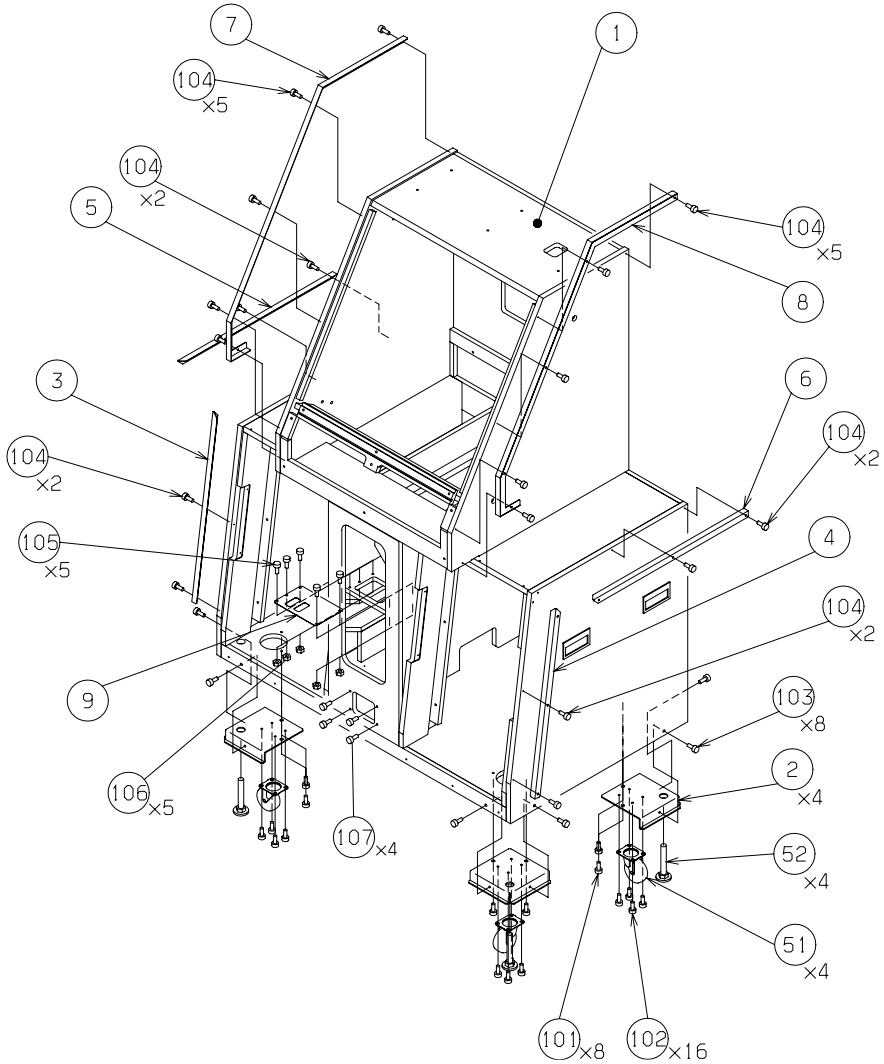
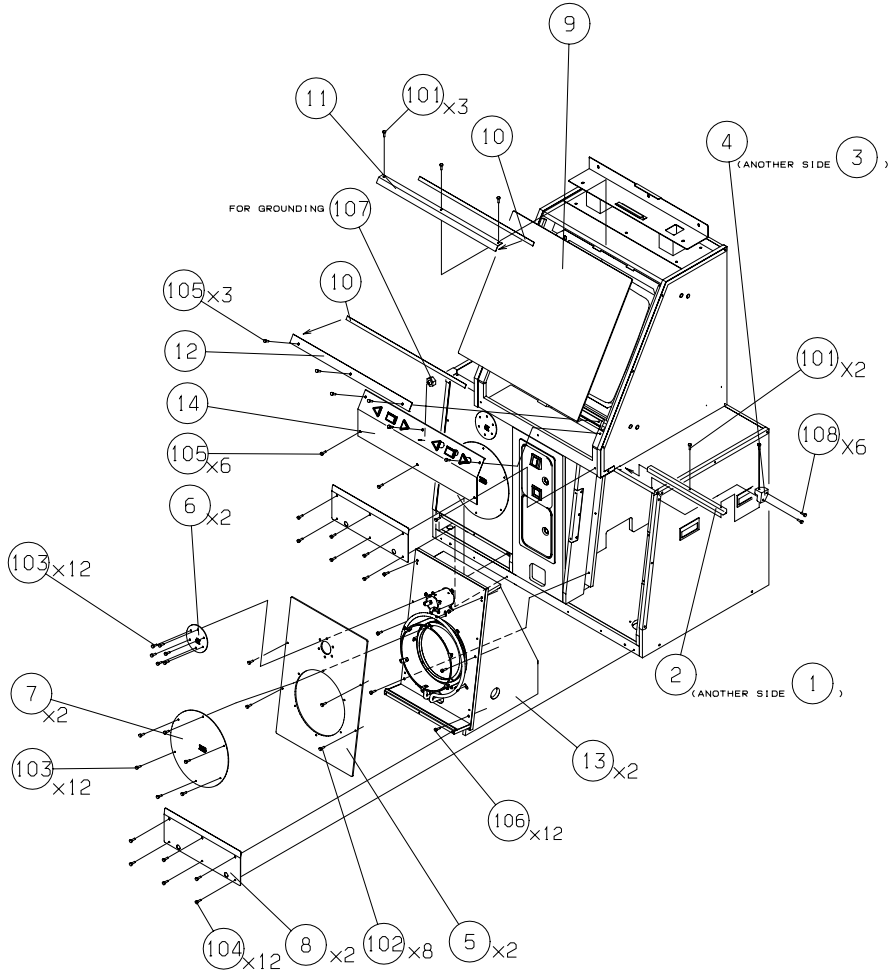

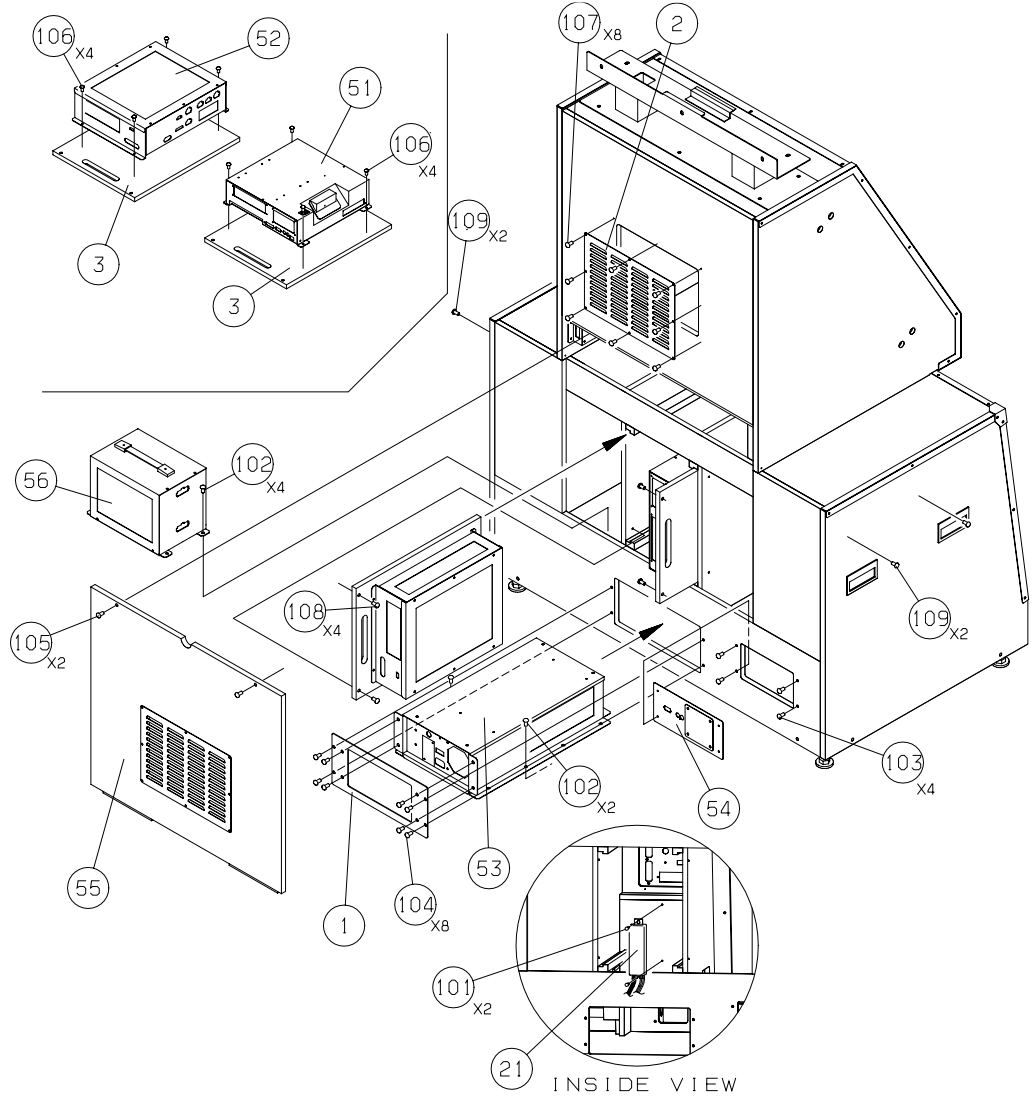

FIG.3 UNIT, CABINET(3/4)

NO.	CODE NO.	NAME	SPEC./CATALOG TYPE	QTY	NOTE
1	0000054020	COVER, EDGE		1	
2	0000054021	COVER, EDGE		1	
3	0000055166	COVER, CORNER		1	
4	0000055167	COVER, CORNER		1	
5	0000053982	PANEL, SPEAKER		2	
6	0000052643	NET, SPEAKER		2	
7	0000052644	NET, SPEAKER		2	
8	0000052662	COVER, SPEAKER		2	
9	0000053984	GLASS, MONITOR		1	
10	0000052753	TAPE, SPONGE		2	
11	0000052650	FIXTURE, GLASS		1	
12	0000052632	FIXTURE, GLASS		1	
13	0000052853	ASS'Y, BOX SPEAKER		2	
14	0000053086	ASS'Y, START		1	

NO.	CODE NO.	NAME	SPEC./CATALOG TYPE	QTY	NOTE
101		SCREW, CROSS TRUSS	M4x15/MFCr	5	
102		SCREW, CROSS TRUSS	M4x10/BLACK	8	
103		SCREW, CROSS TRUSS	M4x10/MFCr	24	
104		SCREW, CROSS TRUSS	M4x15/BLACK	12	
105		SCREW, CROSS TRUSS	M6x15/MFCr	9	
106		SCREW, CROSS TRUSS	M6x35/MFCr	12	
107		NUT, FRANGE	M4/MFZn2-C	1	
108		SCREW, CROSS TRUSS	M4x30/BLACK	6	





NO.	CODE NO.	NAME	SPEC. /CATALOG TYPE	QTY	NOTE
1	0000052663	BRACKET, POWER		1	
2	0000052370	COVER, DUCT		1	
3	0000053996	BOARD, PCB		2	
21	0000052770	INVERTER	2JV100-20C-GN845	1	
51	0000064817	UNIT, PCB BOX		1	
	0000058859	UNIT, SECURITY		1	
52	0000053088	UNIT, AMP BOX		1	
53	0000053084	ASS'Y, POWER BOX		1	
54	0000053085	ASS'Y, CONNECTOR		1	
55	0000059111	ASS'Y, DOOR BACK		1	
56	0000037537	ASS'Y, TRANSFORMER		1	

NO.	CODE NO.	NAME	SPEC. /CATALOG TYPE	QTY	NOTE
101		SCREW, CROSS PAN SEMS	M4x15/MFZn2-C	2	PW, SW
102		SCREW, CROSS PAN SEMS	M6x20/MFZn2-C	6	PW, SW
103		SCREW, CROSS TRUSS	M4x20/BLACK	4	
104		SCREW, CROSS TRUSS	M6x15/MFCr	8	
105		SCREW, CROSS TRUSS	M6x40/BLACK	2	
106		SCREW, CROSS TAPPING TRUSS	4x12/MFCr	8	
107		SCREW, CROSS TAPPING TRUSS	4x12/BLACK	8	
108		BOLT, WING	M4X30/MFZn2-C	4	
109		SCREW, CROSS TRUSS	M6X25/BLACK	4	

FIG.4 UNIT, CABINET(4/4)

FIG.5 UNIT, TUBE/ASS'Y DOOR COIN

NO.	CODE NO.	NAME	SPEC./CATALOG TYPE	QTY	NOTE
1	0000052709	BOX, CONNECTOR		2	

NO.	CODE NO.	NAME	SPEC./CATALOG TYPE	QTY	NOTE
51	0000053268	UNIT, WIRING(TUBE)		1	
52	0000068489	UNIT, WIRING(COIN)	ADD-W2(25g)	1	UA
53	0000001676	LOCK	NS-801-1 W/2(5000)	1	
54	0000005537	LOCK	NS-812 W/2(RANDOM)	1	
55	0000004799	PLATE, LOCK	No. 2	2	

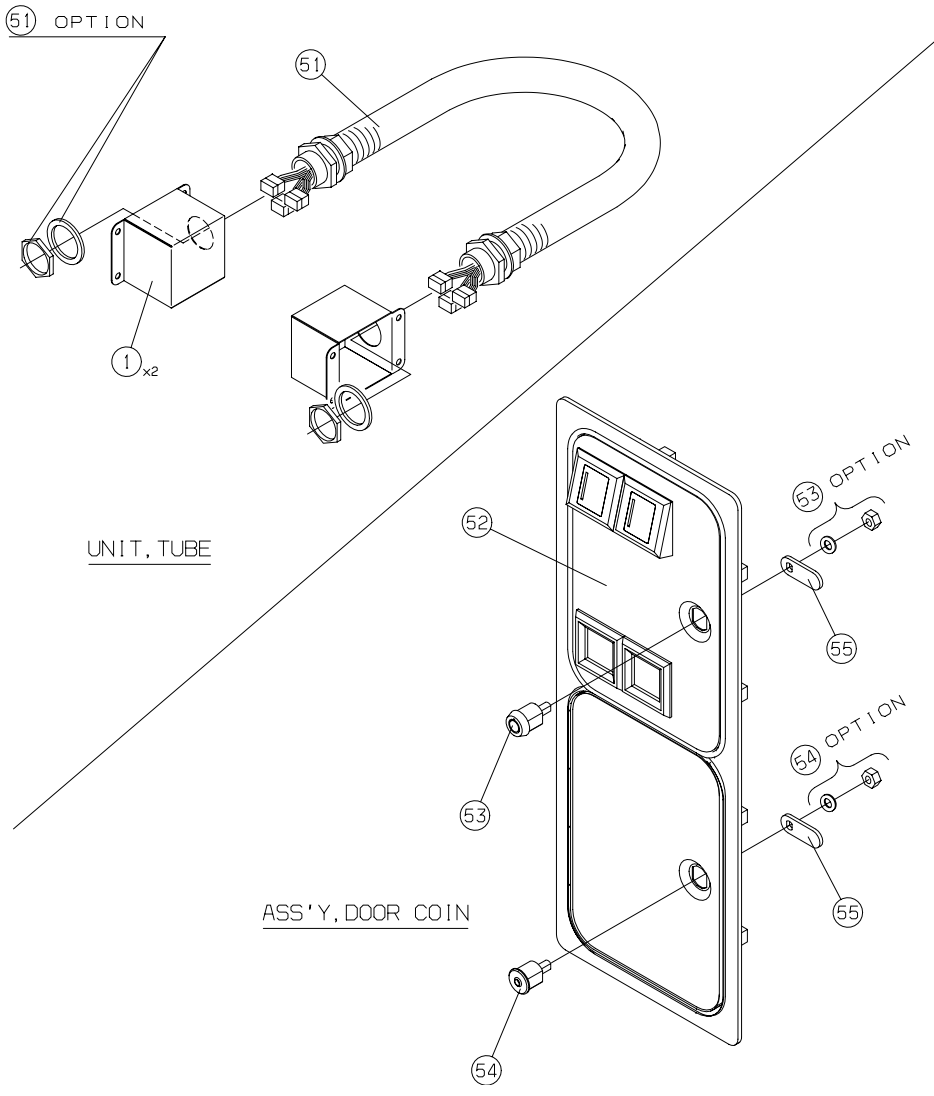



FIG.6 ASS'Y, SERVICE

NO.	CODE NO.	NAME	SPEC./CATALOG TYPE	QTY	NOTE
1	0000038221	BRACKET, SWITCH		1	
2	0000053995	PLATE, SERVICE		1	
3	0000012255	PLATE, COVER		1	
4	0000053270	UNIT, WIRING (VOL.)		1	
5	0000052657	BASE, COINBOX		1	
6	0000052631	PLATE, COUNTER		1	
7	0000053953	PLATE, VOLUME		1	
51	0000038413	BUSH	MP1060	1	
52	0000044953	SWITCH, DOOR	AV1225	1	
53	0000039100	SWITCH, ROCKER	AJ8201BK	1	
54	0000050998	SWITCH, PUSH	DS412 2P	3	
55	0000031436	KNOB	K-75M	2	
56	0000030431	COUNTER	GX-06PD55	1	

NO.	CODE NO.	NAME	SPEC./CATALOG TYPE	QTY	NOTE
101		SCREW, CROSS PAN SEMS	M4x10/MFZn2-C	6	PW, SW
102		SCREW, CROSS PAN PLASTIC	M3x6/PC	3	

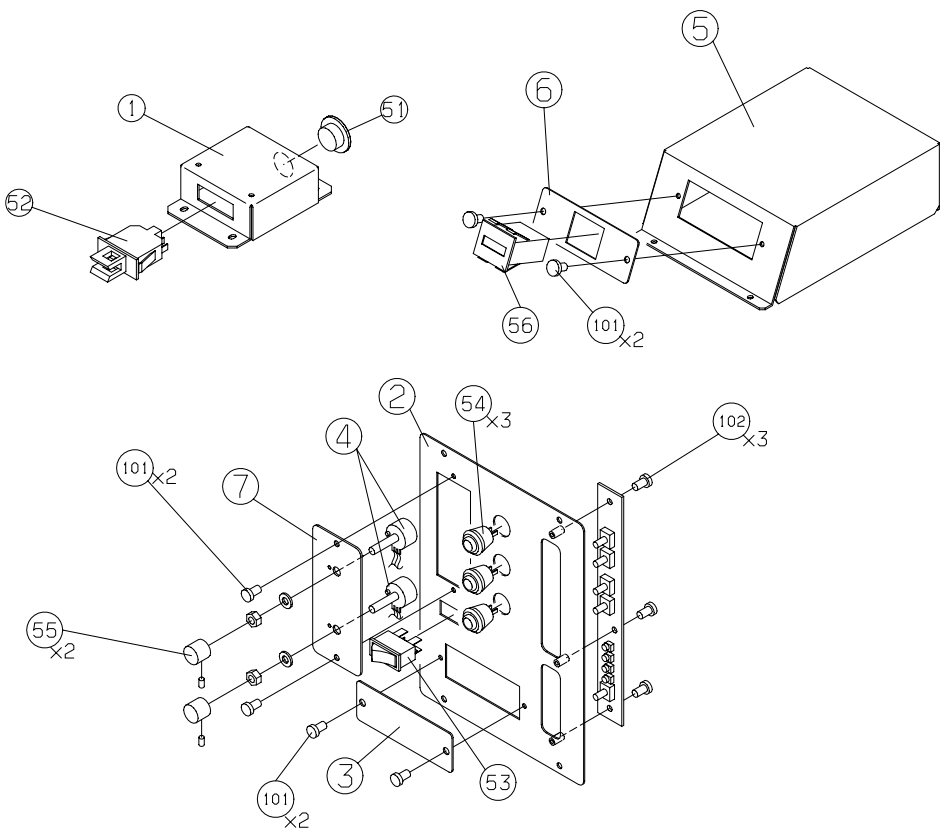
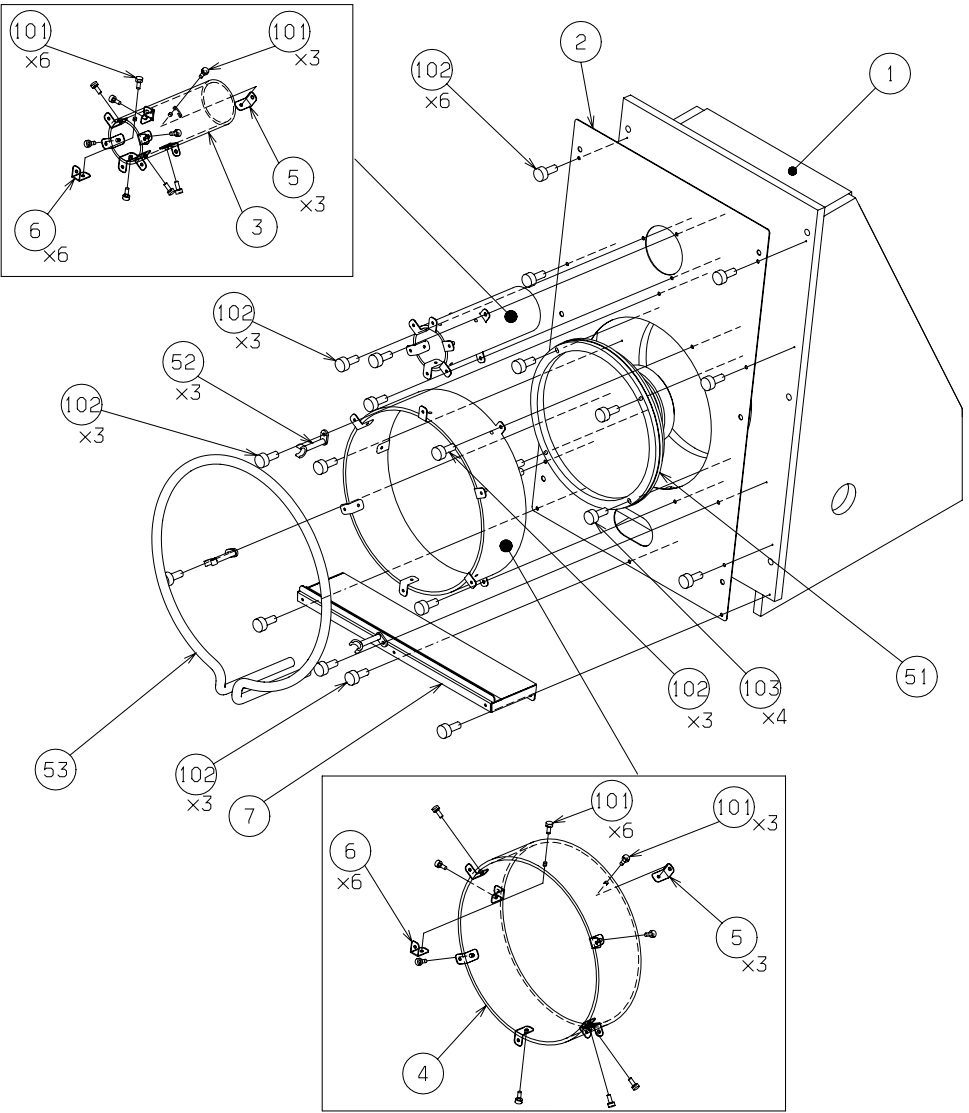
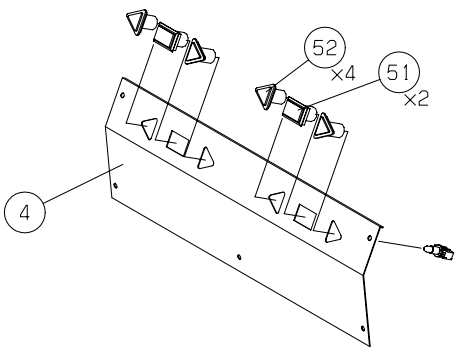
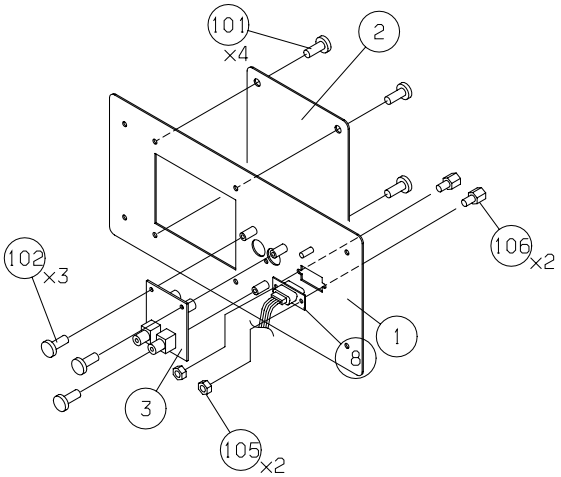

FIG.7 ASSY, BOX SPEAKER

NO.	CODE NO.	NAME	SPEC./CATALOG TYPE	QTY	NOTE
1	0000054007	BOX, ENCLOSURE		2	
2	0000054010	PLATE, REFLECTION		2	
3	0000052742	PIPE, SPEAKER		2	
4	0000052743	PIPE, SPEAKER		2	
5	0000052637	BRACKET, PIPE		12	
6	0000052638	BRACKET, PIPE		24	
7	0000054005	FIXTURE, COVER		2	
51	0000052746	SPEAKER	W2585CON	2	
52	0000052771	SUPPORT, TUBE	YS-50	6	
53	0000052768	LAMP, NEON	NEON-R350P-GN845	2	

NO.	CODE NO.	NAME	SPEC./CATALOG TYPE	QTY	NOTE
101		SCREW, CROSS TRUSS	M4x10/MFCr	36	
102		SCREW, CROSS TAPPING TRUSS	4x12/MFCr	36	
103		SCREW, CROSS TAPPING TRUSS	4x12/BLACK	8	





NO.	CODE NO.	NAME	SPEC./CATALOG TYPE	QTY	NOTE
1	0000052665	BRACKET, CONNECTOR		1	
2	0000052636	COVER, CONNECTOR		1	
3	0000052605	UNIT, PCB(H)		1	
4	0000053985	PLATE, START		1	
5	0000054003	DOOR, BACK		1	
6	0000052370	COVER, DUCT		1	
7	0000038230	PLATE, SWITCH		1	
8	0000053230	WIRE	GN845-JA-WIR57	1	
51	0000034746	BUTTON, PUSH	OBSA-45UK-G	2	
52	0000049173	SWITCH, PUSH	OBSA-30US-Y	4	

NO.	CODE NO.	NAME	SPEC./CATALOG TYPE	QTY	NOTE
101		SCREW, CROSS TRUSS	M4X10/MFCr	4	
102		SCREW, CROSS PAN SEMS	M3X5/MFZn2-C	3	SW
103		SCREW, CROSS TAPPING TRUSS	4X12/BLACK	8	
104		SCREW, CROSS TAPPING TRUSS	4X12/MFCr	2	
105		NUT	M3/MFZn2-C	2	
106		SPACER	17L-003C26	2	

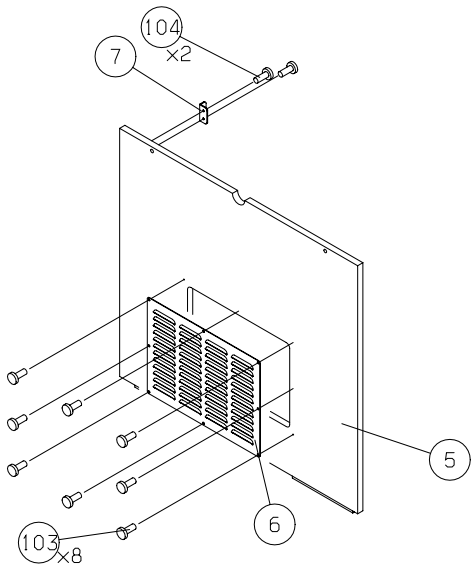
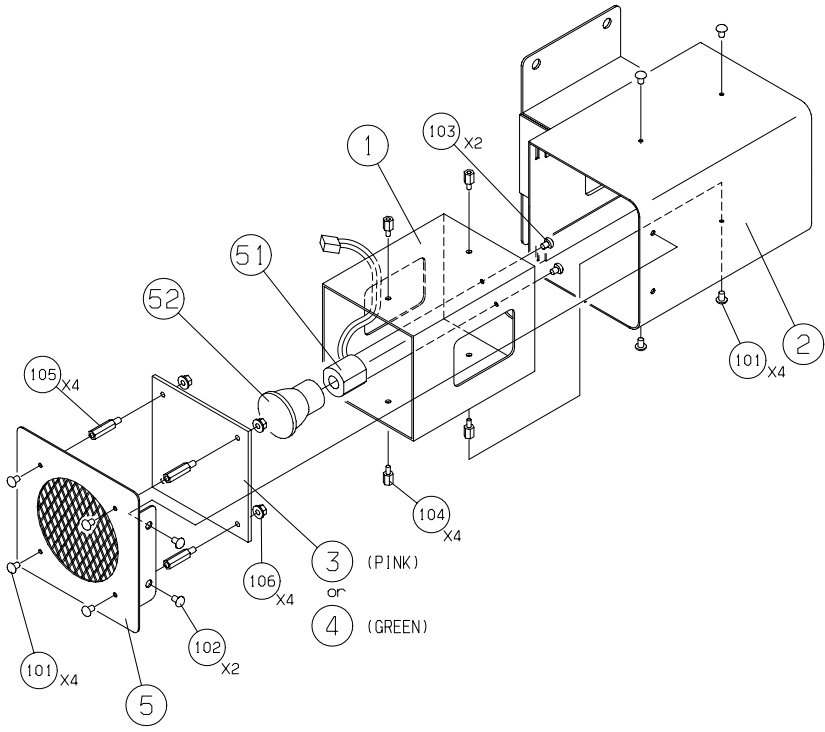

FIG.8 ASSY, START





NO.	CODE NO.	NAME	SPEC. /CATALOG TYPE	QTY	NOTE
1	0000054008	BOX, LAMP		4	
2	0000055665	FIXTURE, LAMP		4	
3	0000053979	COVER, LAMP		2	PINK
4	0000053977	COVER, LAMP		2	GREEN
5	0000055664	COVER, LAMP		4	
6	0000053976	COVER, DUCT		4	
51	0000053318	SOCKET	E10FS-GN845	4	
52	0000053315	LAMP, HALOGEN	JR 12V-20WLW/K3/EZ	4	

NO.	CODE NO.	NAME	SPEC. /CATALOG TYPE	QTY	NOTE
101		SCREW, CROSS TRUSS	M4x6/BLACK	32	
102		SCREW, CROSS TRUSS	M4x10/BLACK	24	
103		SCREW, CROSS PAN SEMS	M3x5/MFZn2-C	8	PW, SW
104		SPACER	BSB-408-7	16	
105		SPACER	BSB-420-7	16	
106		NUT, FLANGE	M4/MFZn2-C	16	

FIG.10 ASS'Y, LIGHT A/B



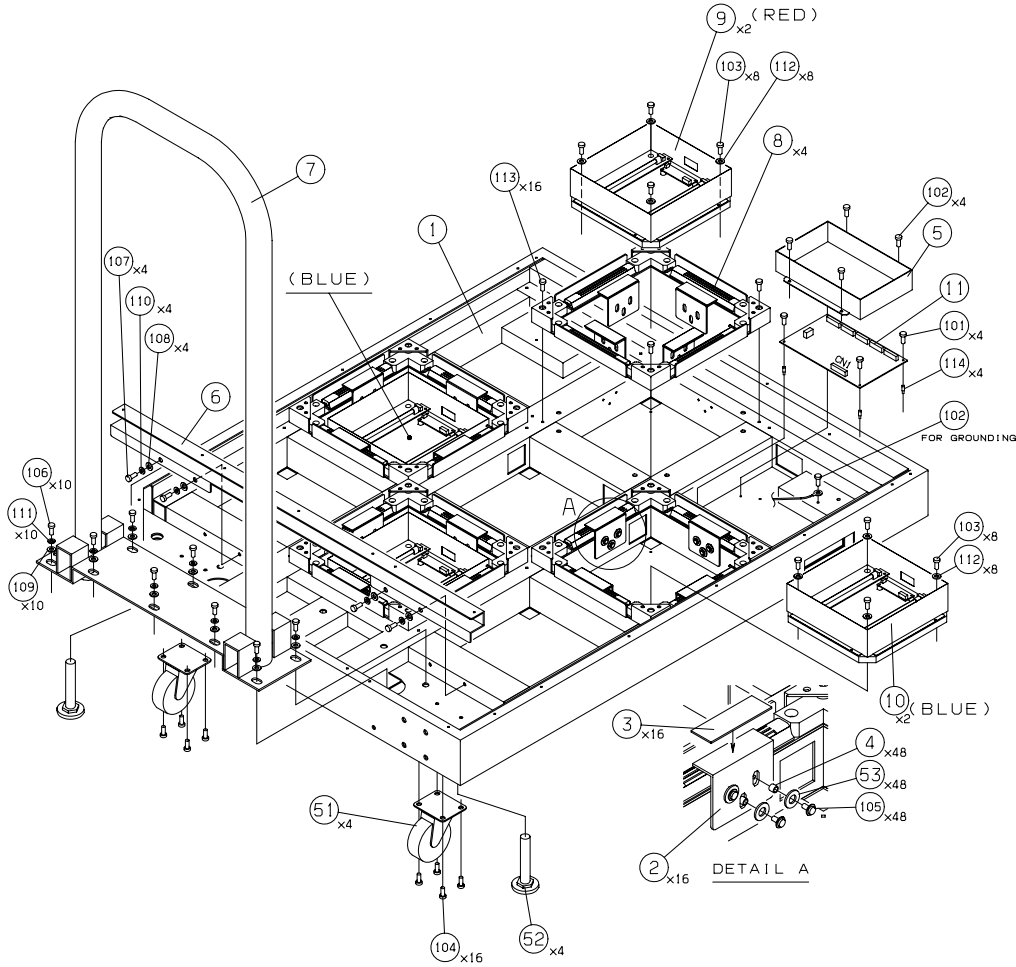

NO.	CODE NO.	NAME	SPEC. /CATALOG TYPE	QTY	NOTE
1	0000054041	FRAME, MAIN		1	
2	0000054031	BRACKET, SWITCH		16	
3	0000052760	TAPE, SPONGE		16	
4	0000053735	SPACER		48	
5	0000054034	COVER, PCB		1	
6	0000054035	BRACKET, COVER		1	
7	0000054039	PIPE, FRAME		1	
8	0000055671	ASS'Y, SWITCH		4	
9	0000053233	ASS'Y, LAMP(R)		2	
10	0000053234	ASS'Y, LAMP(B)		2	
11	0000052648	UNIT, PCB(D)		1	
51	0000047156	CASTER	TCM-75 NM	4	
52	0000053334	ADJUSTER	D-B316*70	4	
53	0000053698	BEARING	WC06DUN	48	

NO.	CODE NO.	NAME	SPEC. /CATALOG TYPE	QTY	NOTE
101		SCREW, CROSS PAN SEMS	M3x5/MFZn2-C	4	PW, SW
102		SCREW, CROSS PAN SEMS	M4x10/MFZn2-C	5	PW, SW
103		SCREW, CROSS PAN SEMS	M4x20/MFZn2-C	16	PW, SW
104		SCREW, CROSS PAN SEMS	M6x15/MFZn2-C	16	PW, SW
105		SCREW, CROSS TP	M4x8/MFZn2-C	48	
106		BOLT, HEX	M10x20/MFZn2-C	10	
107		BOLT, HEX SOCKET, CAP	M6x12/MFZn2-C	4	
108		WASHER, PLAIN	6/BLACK	4	D=Ø20, T=1.6
109		WASHER, PLAIN	10/MFZn2-C	10	
110		WASHER, SPRING	6/MFZn2-C	4	
111		WASHER, SPRING	10/MFZn2-C	10	
112		WASHER, PLAIN	4/MFZn2-C	16	D=Ø14, T=1.0
113		SCREW, CROSS PAN SEMS	M5x10/MFZn2-C	16	PW(Ø10), SW
114		SPACER	MQ-8	4	

FIG.12 UNIT, STAGE L(1/2)





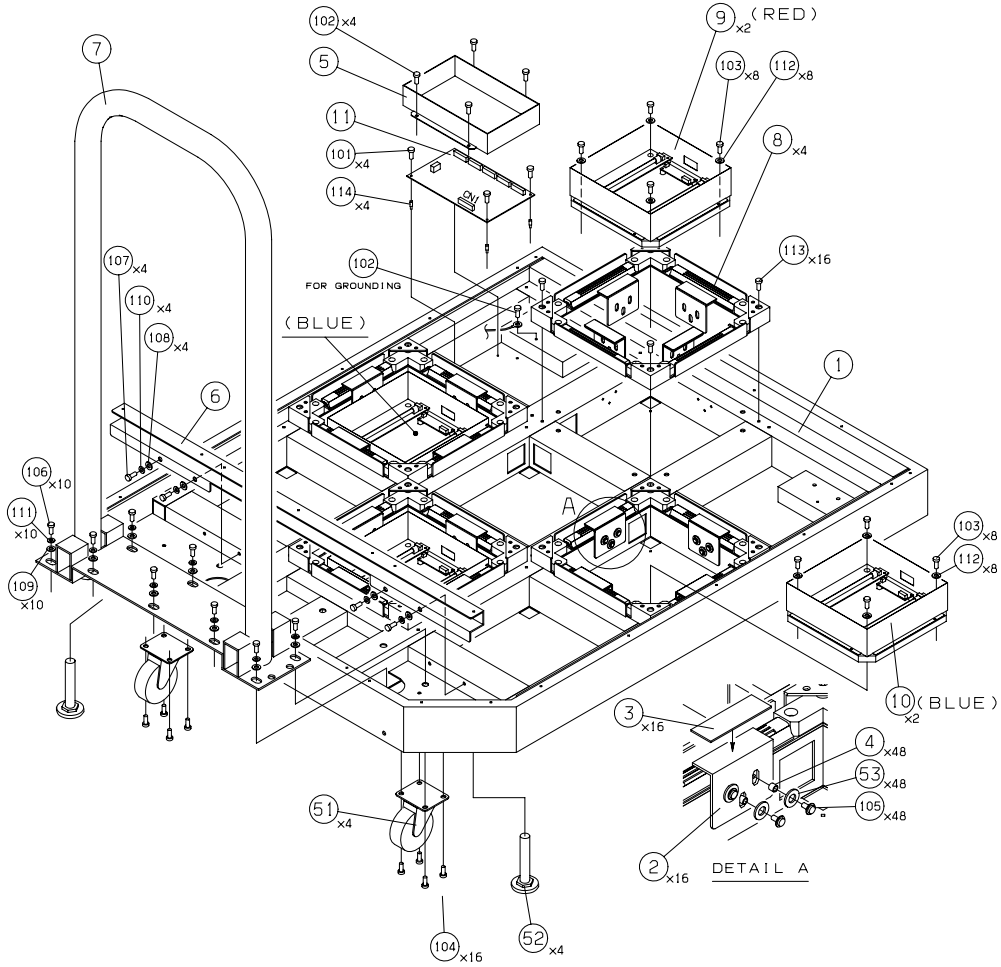

NO.	CODE NO.	NAME	SPEC./CATALOG TYPE	QTY	NOTE
1	0000054040	FRAME, MAIN		1	
2	0000054031	BRACKET, SWITCH		16	
3	0000052760	TAPE, SPONGE		16	
4	0000053735	SPACER		48	
5	0000054034	COVER, PCB		1	
6	0000054035	BRACKET, COVER		1	
7	0000054039	PIPE, FRAME		1	
8	0000055671	ASS'Y, SWITCH		4	
9	0000053233	ASS'Y, LAMP(R)		2	
10	0000053234	ASS'Y, LAMP(B)		2	
11	0000052648	UNIT, PCB(D)		1	
51	0000047156	CASTER	TCM-75 NM	4	
52	0000053334	ADJUSTER	D-B316*70	4	
53	0000053698	BEARING	WC06DUN	48	

NO.	CODE NO.	NAME	SPEC./CATALOG TYPE	QTY	NOTE
101		SCREW, CROSS PAN SEMS	M3x5/MFZn2-C	4	PW, SW
102		SCREW, CROSS PAN SEMS	M4x10/MFZn2-C	5	PW, SW
103		SCREW, CROSS PAN SEMS	M4x20/MFZn2-C	16	PW, SW
104		SCREW, CROSS PAN SEMS	M6x15/MFZn2-C	16	PW, SW
105		SCREW, CROSS TP	M4x8/MFZn2-C	48	
106		BOLT, HEX	M10x20/MFZn2-C	10	
107		BOLT, HEX SOCKET, CAP	M6x12/MFZn2-C	4	
108		WASHER, PLAIN	6/ BLACK	4	D=Ø20, T=1.6
109		WASHER, PLAIN	10/MFZn2-C	10	
110		WASHER, SPRING	6/MFZn2-C	4	
111		WASHER, SPRING	10/MFZn2-C	10	
112		WASHER, PLAIN	4/MFZn2-C	16	D=Ø14, T=1.0
113		SCREW, CROSS PAN SEMS	M5x10/MFZn2-C	16	PW(Ø10), SW
114		SPACER	MO-8	4	

FIG.14 UNIT, STAGE R(1/2)

FIG.15 UNIT, STAGE R(2/2)

NO.	CODE NO.	NAME	SPEC./CATALOG TYPE	QTY	NOTE
1	0000052756	PANEL, SWITCH		2	PINK
2	0000052749	PANEL, SWITCH		2	BLUE
3	0000054032	BRACKET, PANEL		16	
4	0000055771	BRACKET, SUPPORT		5	
5	0000054033	BRACKET, PANEL		5	
6	0000053628	COVER, PIPE		1	
7	0000052724	COVER, FRAME		2	
8	0000052725	COVER, FRAME		1	
9	0000052731	COVER, FRAME		1	
10	0000052723	COVER, FRAME		1	
11	0000052726	COVER, FRAME		1	
12	0000054038	JOINT, FRAME		2	
13	0000054042	BRACKET, SUPPORT		1	

NO.	CODE NO.	NAME	SPEC./CATALOG TYPE	QTY	NOTE
101		SCREW, CROSS TRUSS	M4x10/MFCr	32	
102		SCREW, CROSS TRUSS	M6x10/MFCr	52	SWCH
103		SCREW, CROSS PAN SEMS	M5x10/MFZn2-C	20	PW(Ø10), SW
104		SCREW, CROSS TRUSS	M8x20/BLACK	8	
105		SCREW, CROSS TRUSS	M6x20/BLACK	3	

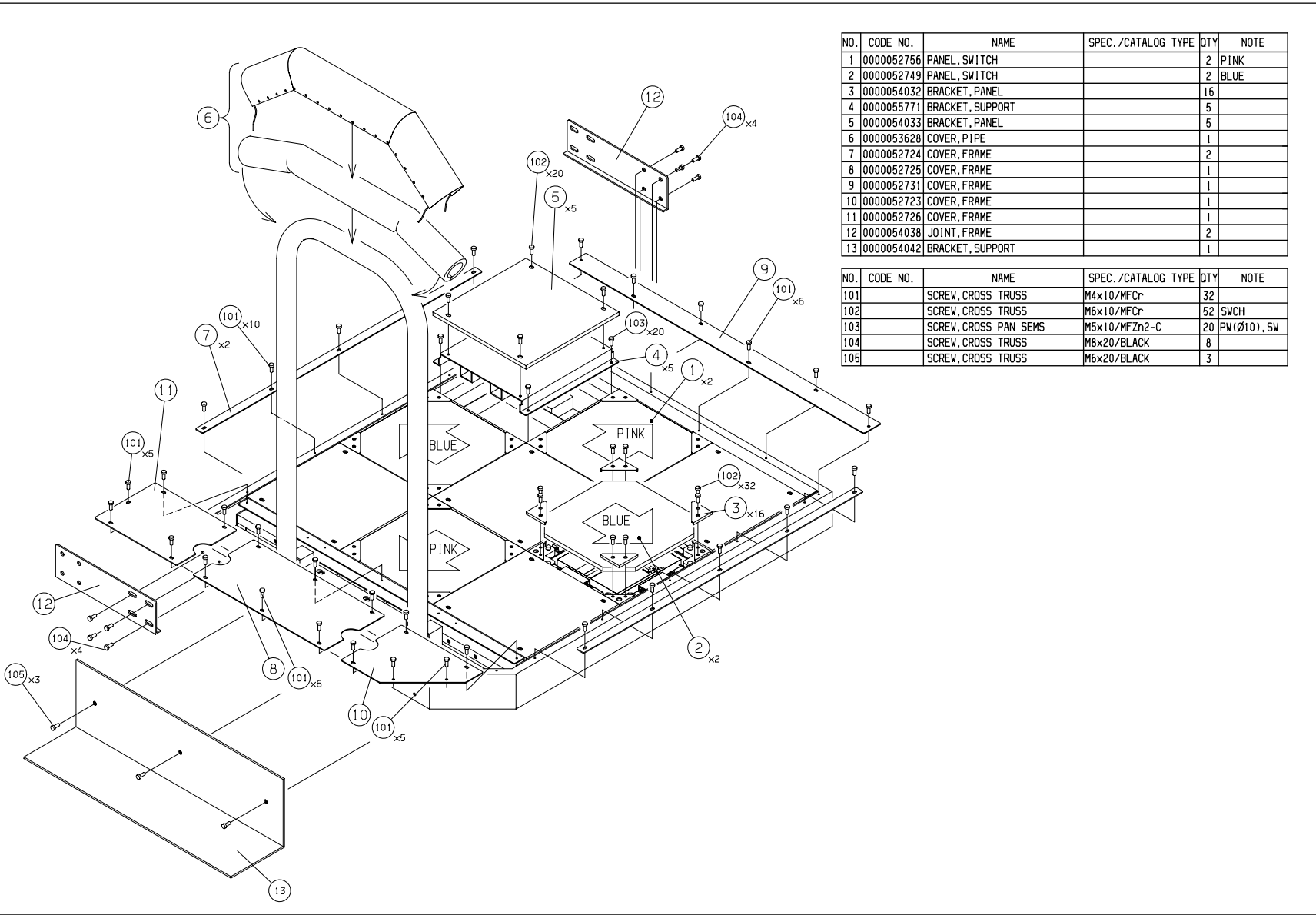

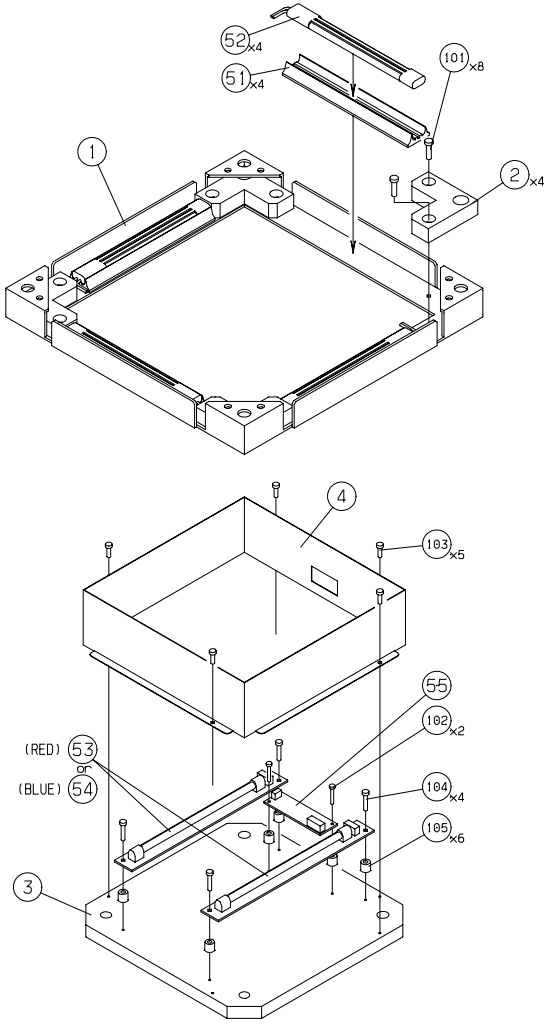

NO.	CODE NO.	NAME	SPEC./CATALOG TYPE	QTY	NOTE
1	0000055663	FRAME, SWITCH		1	
2	0000053987	STOPPER, SWITCH		4	
3	0000053999	BOARD, LAMP		1	
4	0000053983	COVER, LAMP		1	
51	0000052757	CHANNEL, RUBBER	RG601	4	
52	0000052752	SWITCH, CABLE	CB601	4	
53	0000052741	TUBE, COLD CATHODE	HIU-417-L R	1	RED
54	0000052739	TUBE, COLD CATHODE	HIU-417-L B	1	BLUE
55	0000052744	INVERTER	HIU-417	1	

NO.	CODE NO.	NAME	SPEC./CATALOG TYPE	QTY	NOTE
101		SCREW, CROSS PAN SEMS	M4x15/MFZn2-C	8	PW(Ø10), SW
102		SCREW, CROSS WOOD ROUND	2.4x16/MFZn2-C	2	
103		SCREW, CROSS WOOD ROUND	3.1x10/MFZn2-C	5	
104		SCREW, CROSS WOOD ROUND	3.1x16/MFZn2-C	4	
105		SPACER, PLASTIC	4x8	6	

FIG.16 UNIT, STAGE L/R

FIG.17 ASS'Y POWER BOX

NO.	CODE NO.	NAME	SPEC. /CATALOG TYPE	QTY	NOTE
1	0000039940	BOX, DC		1	
2	0000037023	COVER, BOX		1	
3	0000037024	BRACKET, REGULATOR		1	
4	0000053978	BRACKET, REGULATOR		1	
5	0000037028	COVER, RECEPTACLE		2	
6	0000037026	BRACKET, N.FILTER		1	
7	0000037073	SHEET, INSULATION		1	
51	0000002488	REG. SWITCHING	LDA30F-5	1	
52	0000031052	REG. SWITCHING	LDA50F-12	1	
53	0000002489	REG. SWITCHING	LDA150W-12	2	
54	0000003209	MOTOR, FAN	FBA09A12M	1	
55	0000036925	BLOCK, TERMINAL	ML-6750F-187ABC-6P	1	
56	0000003180	FILTER, NOISE	MAS-1210-33	1	
57	0000031709	PROTECTOR, CIRCUIT	NRF110-8A	1	
58	0000039100	SWITCH, ROCKER	AJ8201BK	1	
59	0000037224	UNIT, WIRING (AC IN)		1	AC INLET
60	0000037262	CONNECTOR, RECEPTAC	VLR-03V	1	
61	0000037264	CONNECTOR, RECEPTAC	VLR-06V	1	

NO.	CODE NO.	NAME	SPEC. /CATALOG TYPE	QTY	NOTE
101		SCREW, CROSS PAN SEMS	M3x5/MFZn2-C	20	PW, SW
102		SCREW, CROSS PAN SEMS	M3x15/MFZn2-C	2	PW, SW
103		SCREW, CROSS PAN SEMS	M4x10/MFZn2-C	16	PW, SW
104		SCREW, CROSS PAN SEMS	M4x35/MFZn2-C	4	PW, SW
105		NUT, FLANGE	M4/MFZn2-C	5	
106		SPACER	MQ-8	16	
107		SCREW, CROSS PAN SEMS	M4x15/MFZn2-C	1	PW, SW

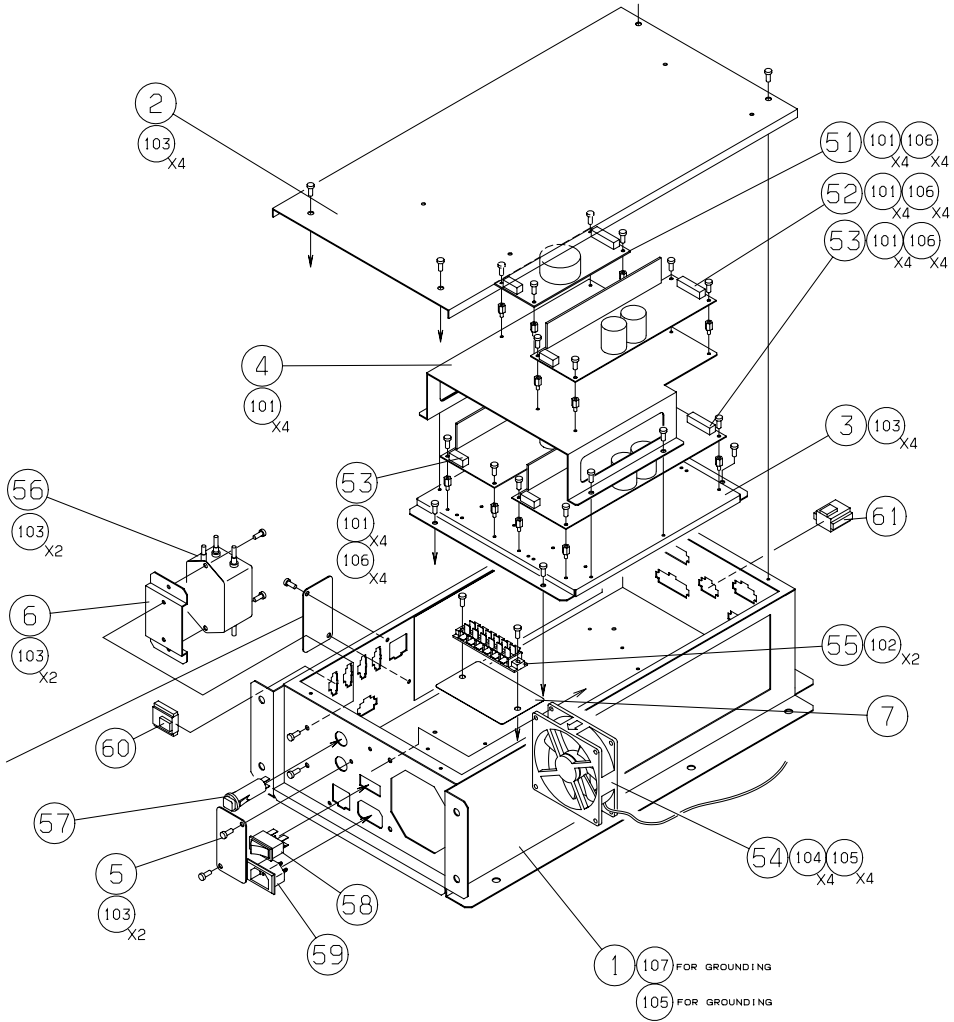

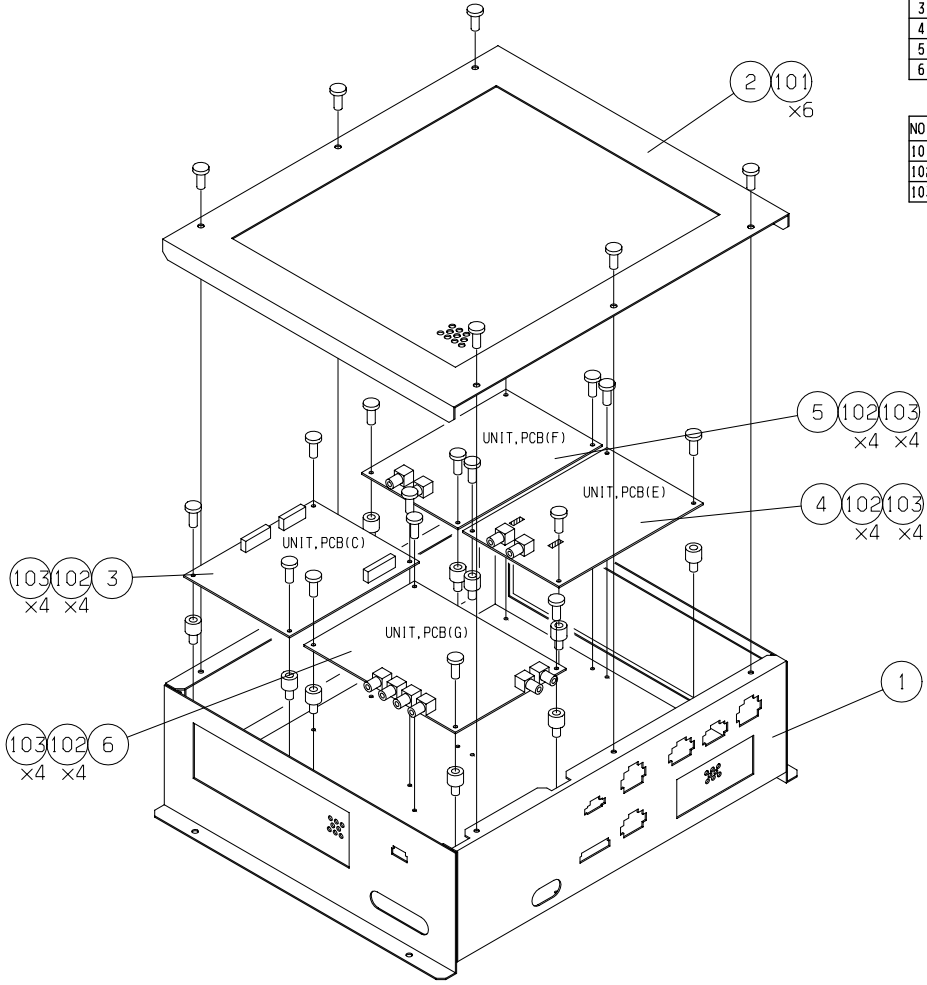

NO.	CODE NO.	NAME	SPEC./CATALOG TYPE	QTY	NOTE
1	0000052711	BOX, AMP		1	
2	0000052706	COVER, BOX		1	
3	0000052598	UNIT, PCB(C)		1	
4	0000052649	UNIT, PCB(E)		1	
5	0000052651	UNIT, PCB(F)		1	
6	0000052653	UNIT, PCB(G)		1	

NO.	CODE NO.	NAME	SPEC./CATALOG TYPE	QTY	NOTE
101		SCREW, CROSS PAN SEMS	M4X10/MFZn2	6	
102		SCREW, CROSS PAN SEMS	M3X6/MFZn2	16	
103		SPACER	BSB-305-6	16	

FIG.18 UNIT, BOX AMP

FIG.19 ASS'Y, TRANSFORMER

NO.	CODE NO.	NAME	SPEC. /CATALOG TYPE	QTY	NOTE
1	0000036571	COVER, TRANSFORMER		1	
2	0000036573	BASE, TRANSFORMER		1	
3	0000036586	HANDLE, VINIL		1	
4	000002707	TRANSFORMER	PT1005/1KVA	1	

NO.	CODE NO.	NAME	SPEC. /CATALOG TYPE	QTY	NOTE
101		SCREW, CROSS FLAT	M4x15/MFZn2-C	2	
102		SCREW, CROSS PAN SEMS	M4x10/MFZn2-C	8	
103		SCREW, CROSS PAN SEMS	M6x12/MFZn2-C	4	

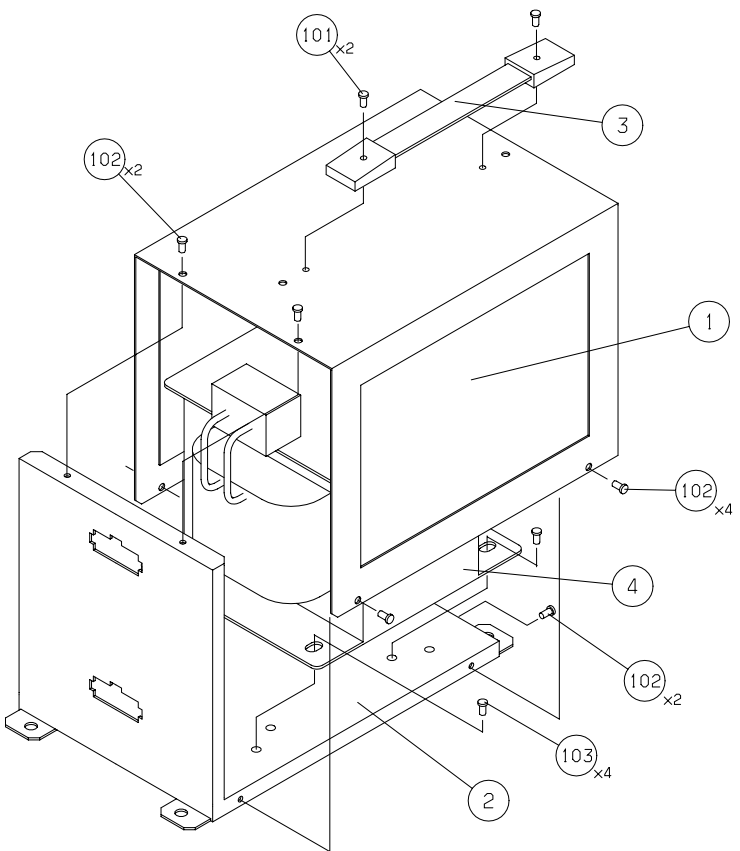

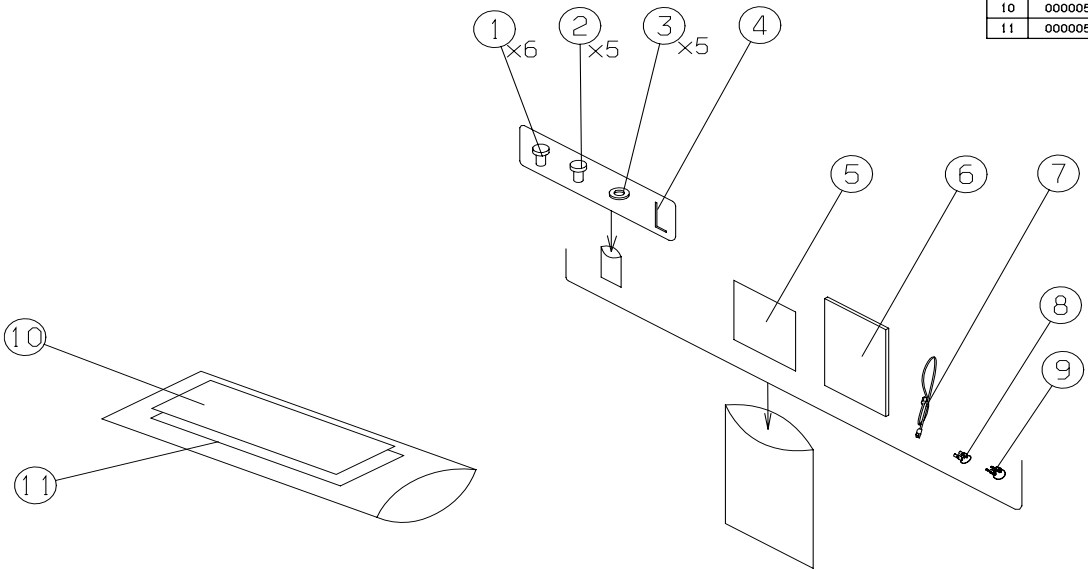

NO.	CODE NO.	NAME	SPEC/CATALOG TYPE	QTY	NOTE
1		SCREW, CROSS TRUSS	M6x20/BLACK	6	
2		BOLT, BUTTON HEAD	M6x20/BLACK	5	
3		WASHER, PLANE	6/BLACK	5	
4	0000004555	WRENCH KEY, HEXAGON	B4	1	
5	0000059047	LABEL, INST/HD		1	
6	0000068482	BOOK, MANUAL/LC		1	
7	0000036690	CABLE, AC		1	
8	0000001676	LOCK	NS-801-1 W/2(5000)	1	2-PIECE SET
9	0000005537	LOCK	NS-812 W/2(RANDOM)	1	2-PIECE SET
10	0000059045	POP		1	
11	0000059046	POP		1	

FIG.20 UNIT, ATTACHMENT

# MEMO

---



# 8-2 Wiring diagram

GN845-UC specifications for regions using 120 voltage area in the U.S.A..

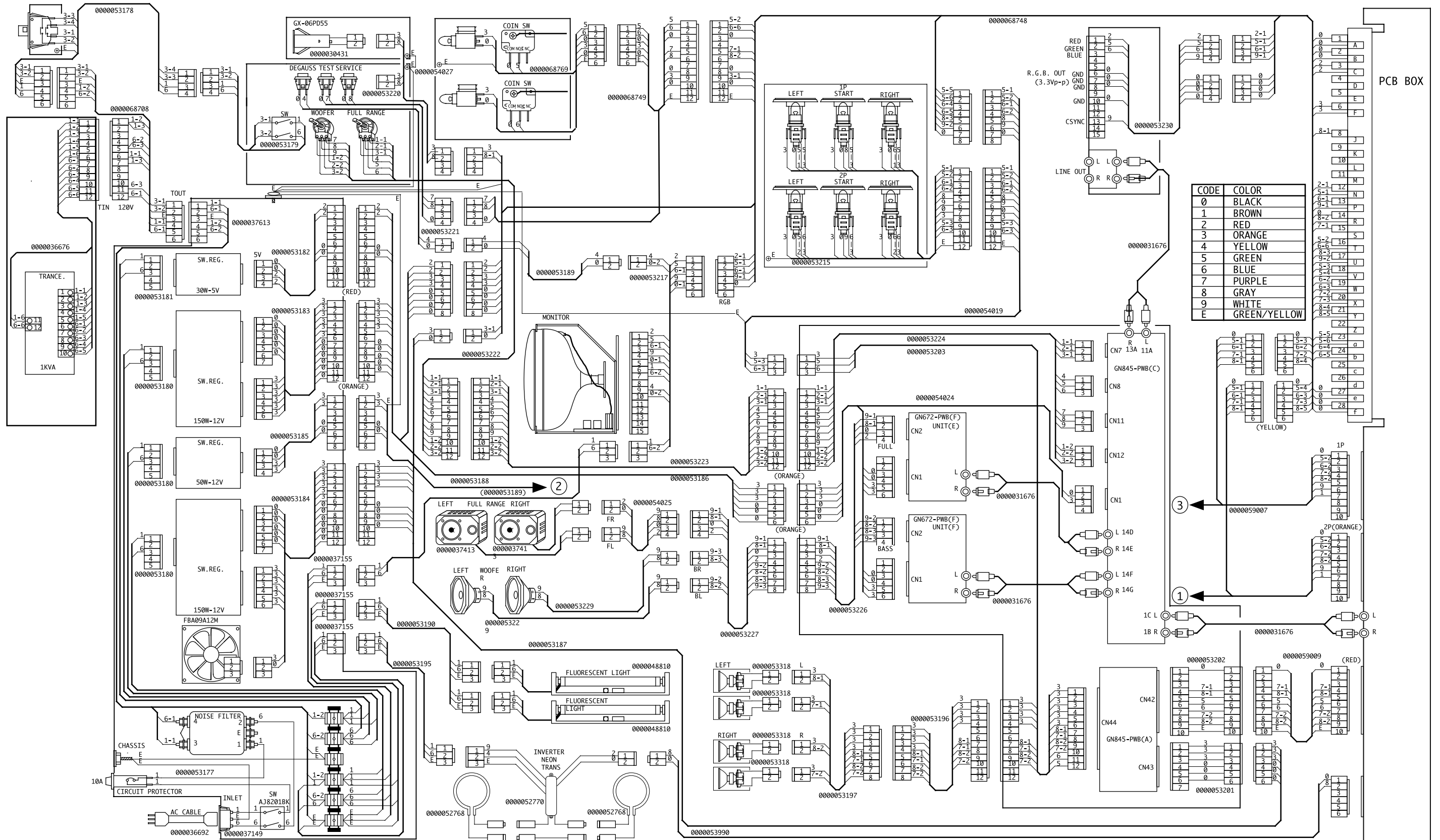

# Wiring diagram

GN845-UC specifications for regions using 120 voltage area in the U.S.A.. 2/2

